

**ADAMS COUNTY
DEPARTMENT OF PUBLIC WORKS
Engineering Division**

TRAFFIC SIGNAL PROJECT SPECIAL PROVISIONS

The 2005 Standard Specifications for Road and Bridge Construction by the Colorado Department of Transportation (CDOT) controls construction of this project. The following special provisions supplement or modify the Standard Specifications and take precedence over the Standard Specifications and plans. When specifications or special provisions contain both English units and SI units, the English units apply and are the specification requirement.

In addition to requirements of the Colorado Department of Transportation Standard Specifications for Road and Bridge Construction, and the Contract Documents, all material and work shall conform to the requirements of the National Electrical Line Construction of the Public Utilities Commission, the Standards of the American Society for Testing and Materials (ASTM), the American Standards Association (ASA), and any local ordinance which may apply.

Reference to any portion of the Adams County Traffic Standard Details contained herein shall imply precedence over the CDOT Standard Specifications and Plans, and shall be the requirement.

INDEX TO PROJECT SPECIAL PROVISIONS

Revision of Section 105 - Control of Work.....	PSP-1
Revision of Section 107 - Legal Relations and Responsibility to the Public.....	PSP-2
Revision of Section 202 - Removal Of Structures And Obstructions	PSP-3
Revision of Section 202 - Removal Of Traffic Signal Equipment.....	PSP-5
Revision of Section 210 - Reset Structures	PSP-6
Revision of Section 613 - Electrical Conduit – General.....	PSP-7
Revision of Section 613 - Lighting.....	PSP-11
Revision of Section 613 - Pull Box - General.....	PSP-12
Revision of Section 613 - Wiring	PSP-13
Revision of Section 613 - Solar collection System.....	PSP-16
Revision of Section 614 - Illuminated Signs.....	PSP-17
Revision of Section 614 - Blank Out Signs	PSP-19
Revision of Section 614 - Traffic Control Devices.....	PSP-20
Revision of Section 614 - Traffic Signal Controller.....	PSP-23
Revision of Section 614 - Traffic Signal Controller Cabinet.....	PSP-25
Revision of Section 614- Traffic Signal Poles	PSP-38
Revision of Section 614 - Traffic Signal Face.....	PSP-40
Revision of Section 614 - Pedestrian Signal Face	PSP-41
Revision of Section 614 - Pedestrian Push Button.....	PSP-42
Revision of Section 614 - Traffic Signal Vehicle Detector Amplifier.....	PSP-34
Revision of Section 614 - Loop Detector Wire	PSP-36
Revision of Section 614 - Fire Preemption Unit and Timer.....	PSP-37

INDEX TO PROJECT SPECIAL PROVISIONS (cont)

Revision of Section 614 - Intersection Detection System (Camera)	PSP-48
Revision of Section 614 - Flashing Beacon	PSP-50
Revision of Section 614 - Uninterrupted Power Supply	PSP-52
Revision of Section 614 - Interconnect Wire	PSP-53
Revision of Section 614 - Fiber Optic Cable - General.....	PSP-54
Revision of Section 614 - Loose Tube Fiber Optic Cable.....	PSP-57
Revision of Section 614 - Test Fiber Optic Cable	PSP-64
Revision of Section 614 - Telemetry (Field).....	PSP-72
Revision of Section 614 - Spread Spectrum Radio	PSP-75
Revision of Section 625 - Construction Surveying	PSP-76
Revision of Section 630 - Construction Traffic Control.....	PSP-77
Traffic Control Plan - General	PSP-78
Utilities -	PSP-80

**REVISION OF SECTION 105
CONTROL OF WORK**

Section 105 of the Standard Specifications is hereby revised as follows:

Subsection 105.2(b) shall hereby include the following:

After contract award, prior to installation, and/or at the Engineer's request, the Contractor shall submit shop drawings and specifications for equipment and materials the Contractor proposes to furnish. The shop drawings and specifications shall be complete as to name of manufacturer, size, and catalog number of unit, and shall be supplemented by such other data as may be required. The Engineer's approval shall be required prior to installation.

Subsection 105.3 shall hereby include the following:

Inspection or sampling of any materials, other than those materials already approved by the Engineer, must be made by the Engineer prior to installation. If the Contractor proposes a substitution of material called for in the plans as specifically defined in these specifications, or as shown in approved submittals and shop drawings, the Contractor shall provide additional information to prove the substitution item is of equal or superior quality. Any material and/or equipment installed by the Contractor that is not in conformance with the project specifications shall be removed or changed at the Contractor's expense.

END REVISION OF SECTION 105

**REVISION OF SECTION 107
LEGAL RELATIONS AND RESPONSIBILITY TO THE PUBLIC**

Section 107 of the Standard Specifications is hereby revised as follows:

Subsection 107.12 shall hereby include the following:

The Contractor shall assume full responsibility and expense for the protection of all public and private property, structures, water mains, sewers, utilities, etc., both above and below ground, at or near the site or sites of the work being performed under the Contract, or which are in any manner affected by the prosecution of the work or the transportation of personnel and materials in connection therewith.

END REVISION OF SECTION 107

**REVISION OF SECTION 202 -
REMOVAL OF STRUCTURES AND OBSTRUCTIONS**

Section 202 of the Standard Specifications is hereby revised as follows:

Subsection 202.02 shall be revised to include the following:

The Engineer will mark the limits of removals in the field.

Subsection 202.03 is hereby replaced as follows:

All salvable material shown on the plans shall be removed, without unnecessary damage, in sections or pieces that may be readily transported, and delivered by the Contractor to the location noted on the plans, or as directed by the Engineer. The Contractor shall be held responsible for the safekeeping of all salvable materials during the period of the Contract until they are delivered to the County. The Contractor shall make good or replace at his own expense any such materials damaged, stolen or otherwise lost prior to receipt by the County. All salvable materials, as designated on the plans, shall remain the property of the County.

Subsection 202.07 is hereby replaced as follows:

All concrete pavement, sidewalks, structures, curbs, gutters, asphalt pavement, etc., designated for removal, shall be broken into pieces and disposed of outside the limits of the project, unless otherwise designated on the plans, or as directed by the Engineer.

Old concrete construction which abuts new construction, edges of pavement, sidewalks, curbs, etc., to be left in place shall be saw cut to true line with a vertical face.

Where old asphalt construction abuts new construction, edges of asphalt pavement, patching, etc., asphalt to be left in place shall be wheel cut or sawcut to a neat vertical face with minimal jagged edges to the satisfaction of the Engineer. The Engineer, at his discretion, may require asphalt to be sawcut.

Removal of stone curb shall include the complete removal of the curb head and concrete foundation. No payment will be made for sprinkler relocation, utility relocation, etc., beyond the limits of construction as shown on the plans. Stone curb designated for salvage shall be carefully removed to prevent damage and delivered to the location indicated in the plans or specifications, or as directed by the Engineer.

Subsection 202.09 shall be revised to include the following:

Removal of asphalt mat from gutters shall be accomplished by planing, and/or scraping. If the existing gutter is to remain, the gutter shall be cleaned by sandblasting until the pan is completely clean of residue. Gutters which are excessively (greater than one-quarter inch in depth) planed or damaged shall be removed and replaced by the Contractor at his expense. If gutter is designated for removal, no separate payment shall be made for asphalt removal.

**REVISION OF SECTION 202
REMOVAL OF STRUCTURES AND OBSTRUCTIONS**

Subsection 202.11 shall be revised to include the following:

Removal of concrete paving, crosspans, curb ramps, driveways will be measured by area in square yards, regardless of thickness.

Removal of asphalt mat will be measured by square yard. If the existing asphalt mat is over 9" thick, the unit price will be increased in proportion to the additional thickness (18" asphalt mat will be paid at twice the unit price). If the asphalt mat is greater than 4" and is over concrete pavement, both asphalt removal and concrete pavement removal will be paid. If the asphalt mat is less than 4" and is over concrete pavement, only concrete pavement removal will be paid.

Removal of asphalt mat (planing) will be measured by the square yard, regardless of thickness.

Removal of asphalt mat from concrete gutter and other concrete designated to remain shall be measured by the square yard. Removal of asphalt mat from gutter shall include sandblasting and compressed air cleaning as part of that pay item.

Subsection 202.12 is hereby deleted and replaced as follows:

The accepted quantities will be paid for at the contract unit price for each of the pay items listed below that appear in the bid schedule. Payment shall be full compensation for sawcutting, scraping, sandblasting, removing, hauling and disposal of such items, excavation and subsequent backfill (with moisture/density control per the Revision of Subsection 203.07) to proposed subgrade elevation. The price shall also include salvageable materials removed, their custody, preservation, storage, haul and disposal as provided herein.

Payment will be made under:

Pay Item	Pay Unit
Removal of Structures and Obstructions	Lump Sum.
Removal of _____	Each, L.F., C.F. S.F., S.Y.
Removal of Stone Curb (Salvaged and Returned to County)	L.F.
Removal of Asphalt Mat from Gutter	S.Y.
Removal of Asphalt Mat	S.Y.
Plug _____	Each
Clean _____	Each
Abandon _____	Each
Sandblasting	S.F.
Sandblasting Existing Reinforcing Steel	S.Y.

When the Contract does not include pay items for Removal of Structures and Obstructions, the removal will not be paid for separately but shall be included in the work.

END REVISION OF SECTION 202

**REVISION OF SECTION 202
REMOVAL OF TRAFFIC SIGNAL EQUIPMENT**

Section 202 of the Standard Specifications is hereby revised as follows:

Subsection 202.02 shall include the following:

Removal items shall be as indicated in the pay item list and shall consist of the items specifically identified on the plans, or in writing by the Engineer. It shall be the Contractor's responsibility to assure that the Contractor has a full and complete understanding of included items prior to bidding.

Subsection 202.03 shall include the following:

Removal of the traffic signal equipment shall include signal poles, luminaries, pedestal poles, footings, span wire cable, mast arms, traffic signal controller and cabinet, pedestrian push button, cabinet footings, all attachment hardware, and all incidental equipment, except as noted on plans. All existing foundations shall be removed to a depth indicated by the Engineer. All wiring shall be removed from existing conduit and the conduit shall be abandoned in place. The Contractor shall restore disturbed areas affected by removals. Restoration of landscaped areas shall include re-seeding, re-sodding, or other such treatment that restores the disturbed area to its original condition. Restoration shall be considered incidental to the work being performed.

Subsection 202.04 shall include the following:

All "Light Emitting Diode" (LED) signal lenses in existing signal faces shall be removed prior to the removal of the signal face and shall be protected from damage. All traffic signal equipment which is removed shall remain the property of the County unless otherwise specified by the Engineer. County property shall be removed from the work site and returned by the Contractor to the County at 4955 East 74th Ave., Commerce City, Colorado 80022. Delivery of salvaged equipment shall be included in the cost of Removal of Traffic Signal Equipment and will not be paid for separately.

Subsection 202.12 shall include the following:

Pay Item	Pay Unit
Removal of Traffic Signal Equipment	Lump Sum

Payment includes all labor, equipment and materials necessary to complete the work.

END REVISION OF SECTION 202

**REVISION OF SECTION 210
RESET STRUCTURES**

Section 210 of the Standard Specifications is hereby revised as follows:

Subsection 210.01 shall hereby include the following:

Reset pay items shall be as indicated in the pay item list and shall consist of the items specifically identified in the plans, or in writing by the Engineer. It shall be the Contractor's responsibility to assure that the Contractor has a full and complete understanding of included items prior to bidding.

Subsection 210.12 shall hereby include the following

Reset items are to be initially removed, then adjusted or modified as directed by the Engineer, and finally reinstalled to full operational capability. Modifications and adjustments shall be detailed on the plans or stated in writing by the Engineer, and shall be incidental to the reset pay item.

END REVISION OF SECTION 210

**REVISION OF SECTION 613 -
ELECTRICAL CONDUIT - GENERAL**

Section 613 of the Standard Specifications is hereby revised for this project as follows:

Add the following to subsection 613.07:

New conduit runs shown on the plans are for bidding purposes only and may be changed at the direction of the Engineer.

Directional boring is the preferred method of conduit installation. Bored conduit shall be used in all hard paved areas and installed per industry standard. Bored conduit runs shall be un-spliced from pull box to pull box. For all new conduit installations, PVC or Schedule 80 polypipe shall be understood unless otherwise defined. Excavation of roadway surfaces will not be allowed unless approved by the Engineer, or as specified in the plans. All roadway and/or hard paved surfaces damaged during the installation of conduit shall be restored in kind equal to or exceeding the original conditions, or as approved by the Engineer, at no additional cost.

The installation of conduit or cable requiring excavation shall be performed in such a manner as to avoid unnecessary damage to streets, sidewalks, landscaping, sprinkler systems and other improvements. Trenches shall not be excavated wider than necessary for the installation of the electrical appurtenances. Excavation shall not be performed until immediately before installation of conduits. The material from the excavation shall be placed in a position not to cause damage or obstruction to vehicular or pedestrian traffic or interfere with surface drainage.

Conduit bends, except factory bends, shall have a radius of not less than six (6) times the inside diameter of the conduit. Where factory bends are not used, conduit shall be bent without crimping or flattening, using the longest radius practicable. Conduit bends feeding pull boxes and foundations shall have an eighteen (18) inch radius as shown on the standard details. All signal wiring conduit installed shall be fully compatible with fiber optic cable.

Conduit shall be laid at a depth of not less than thirty (30) inches below the finished roadway grade and twenty-four (24) inches below the finished grade in all other areas. Conduit under railroad tracks shall be at the minimum depth below the bottom of tie required by the particular railroad company.

Conduit shall always enter a pedestal base, pull box, pole foundation, cabinet foundation, or any other type structure from the direction of the run only. Conduit connections at junctions shall be tightly secured.

All conduit runs that exceed ten (10) feet in length shall have a continuous one-eighth (1/8) inch diameter nylon line pulled into the conduit along with the specified electrical cables. The line shall be firmly secured at each end of the conduit run with three (3) feet of slack. The purpose of this line is to be able to pull future electrical cable through the existing conduit runs. Mule tape shall be installed in place of the nylon line when specified in the plans.

Each conduit with a length greater than 400' between pull boxes, shall be equipped with a pull tape. The pull tape shall have a minimum tensile strength of 1250 lbs. and be of a design and manufacture that prevents cutting or burning into the conduit during cable installation.

A 14 AWG locate wire shall be installed for the complete length of all new conduit runs installed as part of the project. No less than three (3) feet of slack shall remain in each pull box in which the conduit terminates. Where joint trenching is used, only one locate wire need be installed for each joint trench.

-2-
**REVISION OF SECTION 613 -
ELECTRICAL CONDUIT - GENERAL**

Splicing of the locate wire shall not be permitted. Costs for the locate wire shall be incidental to the conduit pay item.

Any spare or unused conduits shall be capped. Conduit plugs for sealing conduit shall also be supplied and installed in all open conduit ends as soon as the conduit is installed. Plugs shall be durable, fabricated from no metallic parts, be of the split design to allow removal and reinstallation around in-place cables and be easily removable and reusable. Plugs shall be capable of being installed by hand without any tools and shall provide a water and air tight seal of at least 100 psi and shall cause no damage to the cable when installed.

Polypipe to PVC coupling shall be completed with the use of "E-Loc" couplings or approved equal.

A two (2) inch PVC conduit shall be installed between the local utility company demarcation point and the controller cabinet home run pull box.

A two (2) inch PVC conduit shall be installed to all signal poles for the exclusive use of the local utility company providing electrical power for luminaires. The conduit may be laid in trenches cut for signal wire conduit and shall run from the controller cabinet home run pull box to signal poles through associated signal pole pull boxes.

When a cabinet is defined as a master cabinet, a two (2) inch PVC conduit shall be installed from the controller cabinet to the designated telephone company demarcation point.

When inductance loops and/or micro loops are required, a two (2) inch PVC conduit shall be installed from the nearest signal pole pull box to a water valve pull box located within the roadway. The material and installation requirements of the water valve pull box shall be as follows;

1. Be constructed of aluminum, with the capability of accepting riser rings for future overlays. The lid shall have the word "TRAFFIC" imprinted on it.
2. Have $\frac{3}{4}$ " to 1" diameter holes either drilled or torched 3" from the top to accept a 4" to 6" long rubber tube (garden hose). The number of holes shall be as per the plans or as directed by the engineer.
3. 2 feet of slack loop wires is to be provided and stored in the water valve pull box.
4. The lid is to be sealed water tight by caulking.
5. To be located in an area of the street where tire traffic is not present, preferably 12" from the concrete gutter pan.
6. The conduit under the roadway serving the pull box shall be at a depth of no less than 30".

The water valve pull box shall be as shown in the Adams County Standard Details. The water valve pull box shall not be paid for separately, but shall be included in the cost of the conduit.

The two (2) inch conduit shall be routed through and terminated within a pull box located adjacent to both the roadway and the associated inductance loop(s). The conduit may be laid in trenches cut for signal wire conduit.

-3-
**REVISION OF SECTION 613 -
ELECTRICAL CONDUIT - GENERAL**

The following conduit schedule is in effect unless otherwise specified in the traffic signal plans.

Run Type	Qty	Size	Use
Street Crossing	1	3"	120VAC Signal Load Wiring
	1	3"	Low Voltage Signal Wiring & Interconnect
	1	3"	Spare
	1	2"	Luminaire Wiring
Signal Pole	1	3"	All Signal Wiring
	1	2"	Luminaire Wiring
Controller Cabinet	1	3"	120VAC Signal Load Wiring
	1	3"	Low Voltage Wiring & Interconnect
	1	3"	Spare
	1	2"	Public Service Utility Power Feed
Inductance Loop	1	2"	Inductance/Micro Loops
Interconnect	1	3"	Interconnect
Service Points	1	2"	Public Service Utility Power Feed
	1	2"	Telephone Service Feed

When a cabinet is defined as a master cabinet, a two (2) inch PVC conduit shall be installed from the controller cabinet to the designated telephone company demarcation point.

If the contractor is unable to bore the conduit at the lengths shown on the plans from pull box to pull box, all splice couplings and associated work to splice the conduit shall be included in the cost of this item. This shall include excavation down to the required depth of conduit at the splice location. Also included in the cost of this item are all landscape repairs, which will be required after excavation of conduit at all splice locations. All splice couplings shall be water and air tight and installed at a depth to match the remaining run of conduit. No elevation difference will be allowed. Splices shall be kept to a minimum and all locations shall be approved by the Engineer. Additional pull boxes shall not be substituted for splices.

If approved, trenches shall be made with a rock-wheel or other machine capable of cutting a narrow trench (4") so as to allow traffic to pass over prior to back filling. The machine shall be equipped with shields to direct the spoil downward and away from passing vehicles, workmen and pedestrians.

Off-street trenches shall be back-filled with the same material that was removed and shall be compacted and shaped to match the surrounding surface. On-street trenches within ALL roadway areas shall be back-filled with CDOT approved Structure Backfill (Flow-Fill) and capped with 6" of Hot Bituminous Pavement (Patching) in accordance with Section 403.

**REVISION OF SECTION 613 -
ELECTRICAL CONDUIT - GENERAL**

All surface materials including sprinkler systems, landscaping, shrubs, sod grass, and native growth vegetation which is disturbed by trenching and back-filling operation shall be restored in kind equal to or exceeding the original conditions. Restoration work shall be incidental to the conduit pay item.

Plastic PVC conduit shall be certified by the manufacturer as meeting ANSI/UL 6 and 651. The manufacturer shall be ISO 9000 compliant.

Subsection 613.10 shall include the following:

Conduit shall be measured and paid for by the linear foot of conduit installed from center of pull box to center of pull box, center of pull box to center of pole, or center of pull box to center of cabinet and shall include all labor, equipment, and materials necessary to install the item complete-in-place. Conduit shall be paid for under the 2" Electrical Conduit (Plastic), 2" Electrical Conduit (Bored) and the 3" Electrical Conduit (Plastic), 3" Electrical Conduit (Bored) pay items.

Subsection 613.11 shall include the following:

Pay Item	Pay Unit
2" Electrical Conduit (Plastic)	Lineal Foot
3" Electrical Conduit (Plastic)	Lineal Foot
2" Electrical Conduit (Bored)	Lineal Foot
3" Electrical Conduit (Bored)	Lineal Foot

END REVISION OF SECTION 613

**REVISION OF SECTION 613 -
LIGHTING**

Section 613 of the Standard Specifications is hereby revised for this project as follows:

Subsection 613.02 shall include the following:

Highway lighting materials and equipment for installation and modifications shall be compatible or interchangeable with standard materials and equipment as stocked by the local utility provider.

Contractor shall submit a lighting materials list to the local utility provider for approval prior to ordering XCEL Contact: (Steve Smith, at 303-571-3945), United Power, Inc Contact: (Main: 303-659-0551)

Subsection 613.08 shall include the following:

At least one grounding electrode shall be installed adjacent to each light standard. Wiring shall be a 120/240 volt or 120/208 volt, 3-wire system with individual luminaries wired for 120 volts.

Subsection 613.11 shall include the following:

Pay Item	Pay Unit
Luminaire HPS (250 Watt)	Each

END REVISION OF SECTION 613

**REVISION OF SECTION 613 -
PULL BOX – GENERAL**

Section 613 of the Standard Specifications is hereby revised for this project as follows:

Subsection 613.01 shall include the following:

At locations shown in the plans, the Contractor shall install one or more pull boxes of the size and type indicated in the following section. This work shall include removal and replacement of the primary cabinet pull box at new cabinet locations.

Subsection 613.02 shall include the following:

A pull box shall be installed at all locations shown on the plans and at such additional points as ordered by the Engineer.

Pull boxes shall be installed so that the covers are level with curb or sidewalk grade or level with the surrounding ground when no grade is established. **The bottoms of all pull boxes shall be set on twelve (12) inches of crushed rock.**

Pull box size shall be as shown in the Plans. With the exception of water valves, pull boxes shall be of "Quazite" or pre-cast ANSI/SCTE 77 2007 polymer concrete type. The following pull box schedule is in effect unless otherwise specified in the traffic signal plans:

Pull Box Usage	Size	Pull Box Lid Marking
Cabinet Home Run Pull Box	24" x 36" x 18"	Traffic
Signal Pole Pull Box	13" x 24" x 12"	Traffic
Detector Pull Box (Side of Road)	12" x 12" x 12"	Traffic
Detector Water Valve	Water Valve	Traffic
Communications Pull Box	24" x 36" x 18"	T/S Communications
Telephone Demarcation	12" x 12" x 12"	T/S Communications
Electrical Demarcation	12" x 12" x 12"	Electric

Pull box lids shall be imprinted with markings as defined in the pull box schedule. Painted markings shall not be permitted.

When a new conduit run enters an existing pull box, the Contractor shall temporarily remove the pull box, or tunnel under the side at no less than eighteen inches (18") below the pull box bottom, and enter from the direction of the run. No new conduit will be allowed to enter a new or existing pull box in any other manner than that shown on the standard details.

Subsection 613.10 shall include the following:

Pull Boxes shall include the removal of any existing pull box, installation of the new pull box, modification of conduit ends, restoration of disturbed surface materials, and all other work necessary to complete the installation.

Subsection 613.11 shall include the following:

Pull Boxes will not be measured and paid separately, but shall be included in the cost of the appropriate conduit pay item.

END REVISION OF SECTION 613

**REVISION OF SECTION 613 -
WIRING**

Section 613 of the Standard Specifications is hereby revised for this project as follows:

Section 613.08 shall include the following:

Wiring shall conform to appropriate National Electrical Code, as applicable. Wiring within cabinets, junction boxes, etc., shall be neatly arranged. Signal conductors shall be No.14 AWG stranded, conforming to IMSA Spec 20-1-1984.

Power feed cable shall be THHN/THWN copper, installed in conduit, and be sized for the electrical load served. The power feed cable shall have a minimum size of #8 and be sized such that the overall voltage drop, between the local utility company demarcation point and controller cabinet, does not exceed 5%. The Contractor shall install a continuous, un-spliced power feed cable from the local utility company power demarcation point to the controller cabinet thru an URD Mold connector located in the controller cabinet home run pull box. URD Mold connectors shall be installed in the home run pull box and shall be used to extend electrical service from the local utility company power demarcation point to the controller cabinet and to street lights on signal poles.

Whenever a raceway is not UL approved, direct burial type insulation shall be required on all associated wiring.

Power cable between the controller cabinet home run pull box and the street lights pole bases shall be type 12-2 UF. Daisy chaining of power cable through the pole bases using SLK connectors shall be permitted. With the exception of the URD Mold connector in the controller cabinet home run pull box, power cable splices within pull boxes shall not be permitted.

Power cable from the end of each street light davit to the base of the signal pole shall be type 12-2 UF with ground. All street light feeds shall be independently fused at the base of each pole.

All signal cables shall be labeled with colored electrical tape based on the table below.

Direction	Tape Color
Northbound Thru	Red
Northbound Left Turn	Red + White
Northbound Pedestrian	Red + Yellow
Southbound Thru	Green
Southbound Left Turn	Green + White
Southbound Pedestrian	Green + Yellow
Eastbound Thru	Orange
Eastbound Left Turn	Orange + White
Eastbound Pedestrian	Orange + Yellow
Westbound Thru	Blue
Westbound Left Turn	Blue + White
Westbound Pedestrian	Blue + Yellow

Signal circuit wiring shall be accomplished in the following manner:

A separate 21 conductor cable shall be installed between the cabinet and each signal pole. Cables shall be continuous with no splices. Conductor usage has been defined in the table below. All unused conductors shall become spare conductors and shall be coiled and taped back to minimize the chance for a short.

-2-
**REVISION OF SECTION 613 -
 WIRING**

21 Conductor Color to Phase Assignment	
Main Street	
Color	Phase
Solid Green	Green
Solid Orange	Yellow
Solid Red	Red
Solid Blue	Left Turn Green
Solid Black	Left Turn Yellow
Red with White Trace	Left Turn Red
Blue with White Trace	Walk
Black with Red Trace	Don't Walk
Side Street	
Green with Black Trace	Green
Orange with Black Trace	Yellow
Red with Black Trace	Red
Blue with Black Trace	Left Turn Green
Black with White Trace	Left Turn Yellow
Red with Green Trace	Left Turn Red
Blue with Red Trace	Walk
Orange with Green Trace	Don't Walk
Right Turn	
Green with White Trace	Right Turn Green
Orange with Red Trace	Right Turn Yellow
AC Return	
Solid White	AC Return
White with Black Trace	AC Return
White with Red Trace	AC Return

Each signal head shall have its own signal cable to the base of the pole that it is mounted on. Cables shall be continuous with no splices. Conductor usage has been defined in the table below. All unused conductors shall become spare conductors and shall be coiled and taped back to minimize the chance for a short.

Conductor Color	7 Conductor (5 Section Head)	5 Conductor (3 Section Head)	5 Conductor (Pedestrian Head)
Red	Red Ball	Red Ball or Red Arrow	Don't Walk
Orange	Yellow Ball	Yellow Ball or Yellow Arrow	Spare
Green	Green Ball	Green Ball or Green Arrow	Walk
Blue	Green Arrow	Not Available	Not Available
Black	Yellow Arrow	Spare	Spare
White	AC Return	AC Return	AC Return
White/Black	AC Return - LT	Not Available	Not Available

-3-
**REVISION OF SECTION 613 -
WIRING**

Outboard signal heads shall use "7 Conductor" cable to accommodate for present or future left turns.

When a cabinet is defined as a master cabinet, phone cable shall be installed in conduit from the controller cabinet to the designated telephone company demarcation point. Phone cable shall be #REA-PE54 or equivalent for telephone service. The cable shall be continuous with no splices and run from the telephone service point to the controller cabinet. Adequate cable length shall remain on both cable ends to permit for proper termination.

Pedestrian push button wire shall be shielded single or multiple twisted pairs in polyethylene jacketed cable. Conductors shall be No. 18 AWG stranded copper, minimum. A stranded tinned copper drain wire shall be provided. Pedestrian push button common wire shall not be connected to the signal neutral circuit.

Inductance detector loop lead-in cable shall be shielded single or multiple twisted pairs in polyethylene jacketed cable. Conductors shall be No. 18 AWG stranded copper, minimum. A stranded tinned copper drain wire shall be provided.

Emergency vehicle detection wiring, Opticom wiring, shall be of the type as specified by equipment manufacturer.

Splicing any conductor, cable or wiring, except loop detector wiring and power cable as defined in these specifications, shall not be permitted in conduit or in pull boxes. All signal conductor splices shall be in the signal pole near the hand hole above grade. Signal load splices shall utilize copper crimp sleeves that compress from four directions as manufactured by Buchanan Company, or approved equal. The crimped sleeve shall then be protected within a flexible rubber insulating cover as manufactured by Ideal Wrap Company, or approved equal. Detector loop lead-in splices in pull boxes below grade shall be fully waterproofed using a DBY-6 splice kit as manufactured by 3M, or approved equal. A minimum of 12-inches of slack shall be left at each splice.

Powdered soapstone, talc, or other approved lubricant shall be used in placing conductors in conduit.

A small permanent tag with the phase and direction printed on it shall be securely attached near the end of each conductor in the controller cabinet. An example is "Ø1-NBLT" where Ø1 is the phase number.

Section 613.10 shall include the following:

Wiring and cabling shall be shall be paid for on a lump sum basis and shall include all labor, equipment and materials necessary to install the item complete-in-place. All cabling and wiring shall be paid for under the "Wiring" pay item.

Section 613.11 shall include the following:

Payment will be made under:

Pay Item
Wiring

Pay Unit
Lump Sum

END REVISION OF SECTION 613

**REVISION OF SECTION 613 –
SOLAR COLLECTION SYSTEM**

Section 613 of the Standard Specifications is hereby revised for this project as follows:

Section 613.02 shall include the following:

The solar collection system shall be of sufficient size to adequately support the power requirements of the attached equipment year round.

The solar collection system shall incorporate a solid-state solar controller including a high output solar regulator and low voltage disconnect.

The solar collection system shall operate on input voltages ranging from 11.5 VDC to 25 VDC.

The solar regulator's minimum rating shall be 25A at 12 VDC, temperature compensation.

The solar panel position shall be field settable to the correct degree required at the location.

The solar collection system shall use automatic night dimming to conserve power.

Section 613.10 shall include the following:

The solar collection system shall not be paid for separately but shall be included in the cost for the equipment it is powering and shall include all labor, equipment, and materials necessary to install a solar collection system, complete-in-place, on a single pole.

END REVISION OF SECTION 613

REVISION OF SECTION 614 - ILLUMINATED SIGNS

Section 614 of the Standard Specifications is hereby revised for this project as follows:

Subsection 614.05 shall include the following:

FLOURESCENT

Illuminated street name signs housings shall be constructed of extruded aluminum. All ferrous hardware parts shall be galvanized and cadmium plated.

The reflectors shall have a minimum reflectance of 85%.

Background sheeting shall be 3M brand DG3 reflective sheeting, series 4090T translucent white. Green transparent overlay film shall be 3M brand electro cut series 1177 green. The County shall provide transparent County logo to be placed on the sign by the manufacturer. Sign panels shall be protected by overlay clear film and shall be 3M brand series 1150 clear. The sign colors shall not fade when exposed to an accelerated test of ultraviolet light equivalent to eight (8) years of outdoor exposure.

The entire surface of the sign panel shall be evenly illuminated. The average of brightness reading for the letters shall be 150 feet – lamberts minimum. The light transmission factor of the sign panel shall provide a letter-to-background brightness ratio between 10:1 and 20:1.

The sign ballasts shall be the high power factor type, rated at 100-125 V. at 60 Hz., and there shall be a separate ballast for each fluorescent lamp. Fuses shall be miniature slow-blowing type, with a separate fuse provided for each ballast. Fluorescent lamps shall meet ANSI Standard C78. One lamp holder for each lamp shall be the spring loaded type. The entire sign and its components shall operate over a temperature range of -30 degrees F. to +160 degrees F.

Terminal blocks shall be molded, phenolic, barrier type rated at 15 ampere, 1000 V and shall have waterproof marking strips. No wiring splices will be permitted within the sign without the permission of the Engineer or his designee.

Illuminated street name signs shall be measured and paid for per unit count and shall include all labor, equipment, and materials necessary to install the item complete-in-place. Illuminated street name signs shall be paid for under the "illuminated street name sign" pay item.

LED/OTHER

LED or other type illuminated street name signs shall only be used where specified in the plans and specifications and may be considered by the Engineer on a per project basis. When specified in the project plans and/or specifications, LED or other type illuminated street name signs shall be of the manufacturer and model number as specified.

Subsection 614.13 shall include the following:

Illuminated signs shall include all labor, equipment and materials necessary to install the items complete-in-place. Illuminated signs shall be measured and paid by the number of units at which the sign is installed. The item shall include all labor, materials, and ancillary hardware required to provide a fully functioning sign system to the satisfaction of the Engineer. Illuminated street name signs shall be paid for under the "Illuminated Sign" pay item.

-2-
**REVISION OF SECTION 614 -
ILLUMINATED SIGNS**

Subsection 614.14 shall include the following:

Pay Item	Pay Unit
Illuminated Sign	Each

END REVISION OF SECTION 614

**REVISION OF SECTION 614 -
BLANK OUT SIGNS**

Section 614 of the Standard Specifications is hereby revised for this project as follows:

Subsection 614.05 shall include the following:

Blank out regulatory or warning sign housings shall be constructed of aluminum unless directed otherwise by the Engineer. All ferrous hardware parts shall be galvanized cadmium plated, or stainless steel.

The lens panel shall be capable of removal or be swung open without the use of tools.

The sign panel shall be completely blanked out when not energized. The sign color shall not fade when exposed to an accelerated test of ultraviolet light equivalent to five years of outdoor exposure.

The entire surface of the sign panel shall be evenly illuminated. All messages shall be clearly legible attracting attention under any lighting conditions for an advance distance of at least 500 feet. When illuminated, the sign shall be visible anywhere within the approximately a 60 degree cone centered about the optic axis.

Terminal blocks shall be molded, phenolic, barrier type rated at 15 ampere, 1000 V and shall have waterproof marking strips. No wiring splices will be permitted within the sign without the permission of the Engineer.

The overall weight of the complete sign assembly including mounting hardware shall not exceed 90 lbs.

Blank out regulatory or warning signs shall be of LED or fiber optic light source type as specified in the project plans and specifications.

If a fiber optic light source is specified, the lamps shall be 50 watts or less, operating at 15 volts or less and shall have an average rated life of 8000 hours or more. The color of any message shall be changeable in the field by replacement of the color filters without removing the sign from the case.

Subsection 614.13 shall include the following:

Blank out regulatory/warning signs shall be measured and paid for per unit count and shall include all labor, equipment, and materials necessary to install the item complete-in-place. Blank out regulatory/warning signs shall be paid for under the "Blank Out Sign" pay item.

Subsection 614.14 shall include the following:

Pay Item	Pay Unit
Blank Out Sign	Each

END REVISION OF SECTION 614

REVISION OF SECTION 614 – TRAFFIC CONTROL DEVICES

Section 614 of the Standard Specification is hereby revised for this project as follows:

Subsection 614.01 shall include the following:

The Contractor shall obtain any and all permits as necessary from the County Public Works Department, Construction Inspection. The Contractor shall obtain and have in his possession all required permits prior to initiation of work. County permits shall be no fee permits.

Subsection 614.10 (a) shall include the following:

All new traffic control equipment including, but not limited to, loops, cameras, poles, control cabinets, conduit, pull boxes, pole foundations and permanent pavement marking material shall be field located by the Engineer. All pole locations shall conform to current ADA requirements regarding accessibility to the pedestrian push buttons that may be mounted to the poles.

Subsection 614.10 (c) shall include the following:

BONDING AND GROUNDING

Metallic cable sheaths, conduit, metal poles and pedestals shall be effectively grounded. Bonding and grounding jumpers shall be copper wire or copper strap of the same cross-sectional area, No. 8 AWG for all systems. Loop lead-in cable for loop detectors is to be grounded in controller cabinet only. The other end of the sheath is to be taped and left ungrounded.

Bonding of standards shall be by means of a bonding strap attached to a brass bolt or a 3/16-inch or larger brass or bronze bolt installed in the lower portion of the shaft.

The controller cabinet and each individual pole and/or pedestal shall be attached to its own separate ground electrode via #6 solid bare copper wire. The ground electrodes may be placed in the foundation of the item to be grounded or may be placed in an adjacent pull box located no more than 6-feet away from said foundation. Ground electrodes shall be a one piece copper weld rod of 5/8-inch diameter, 8-feet in length.

Grounding shall be incidental to the pay item for which it is associated.

Electrical service shall be installed as per NEC or as amended by the County. The grounding and bonding of services shall be completed in accordance with all national, state, and local ordinances that apply.

Electrical service shall not be paid for separately, but shall be included in the cost of the work, and shall include all labor, equipment and materials necessary to install the electrical service, complete-in-place.

Subsection 614.10 (d) shall include the following:

EXCAVATION AND BACKFILLING

The Contractor shall replace or reconstruct sidewalks, curbs, gutters, rigid or flexible pavement, and any other improvements removed during construction with material meeting the requirements of Section 206 of the Colorado Department of Transportation's latest edition or as otherwise directed by the Engineer.

Whenever a part of a square or slab of existing concrete is broken or damaged by the Contractor during construction, the entire square or slab shall be removed and the concrete reconstructed, at no cost to the County.

**REVISION OF SECTION 614 –
TRAFFIC CONTROL DEVICES**

Concrete and asphalt removal shall be cut to a minimum depth of one-and-one-half (1 ½) inches. The cut for the remainder of the required depth may be made by a method satisfactory to the engineer. Cuts shall be neat and true with no shatter outside the removal area. When, in the course of concrete removal, damage occurs to a square or slab of existing concrete outside of the removal area, the square or slab shall be considered damaged with the entire square or slab requiring replacement.

All excavations shall be done in conformance with OSHA regulations. Excavated material shall be removed at the completion of the project or as directed by the Engineer.

Subsection 614.10 (i) shall include the following:

MAINTAINING EXISTING AND TEMPORARY ELECTRICAL SYSTEMS

During the construction, reconstruction, fourteen-day test period, and until signal acceptance by the County, the Contractor shall maintain the system or systems on a 24 hour basis. The cost of any maintenance necessary except electrical energy, and maintenance due to damage by public traffic, shall not be paid for separately but shall be included in the cost of the work.

Acceptance by the County of the work performed by the Contractor shall only take place after all punch list items have been satisfactorily completed and inspected by the County.

The Contractor shall provide the County with a 24 hour one call phone number for reporting of any and all signal malfunctions. Fees incurred for such service shall not be paid for separately but shall be included in the cost of the work.

All malfunctions of a controller and its accessory equipment shall be considered an emergency unless otherwise identified by the County. Equipment malfunctions and/or damage, which in the opinion of the Engineer or other County authorized person, constitutes a serious hazard or inconvenience to the public, shall be considered an emergency. The Contractor shall undertake emergency repairs no later than one (1) hour after the County notifies the Contractor of the emergency.

Malfunctions of a controller and its accessory equipment, which are identified by the Engineer or other County authorized person, as non-emergency repairs shall be considered non-emergency. The Contractor shall undertake non-emergency repairs no later than 24 hours after the County notifies the Contractor of the non-emergency.

If the Contractor fails to respond within the defined response time, the Engineer may elect to employ the services of the County's designated Traffic Signal Maintenance Contractor to perform the said maintenance work. In such cases, the Contractor shall reimburse the County for labor, equipment, and material charges associated with the utilization of the County's designated Traffic Signal Maintenance Contractor plus a fifteen percent administration fee.

Subsection 614.10 (j) shall include the following:

FIELD TESTS AND TURN ON

Prior to completion of the work, the Contractor shall cause the following tests to be made on all traffic signals in the presence of the Engineer:

Testing for signals shall be incidental to the pay item for which signal testing is required.

-3-

**REVISION OF SECTION 614 –
TRAFFIC CONTROL DEVICES**

There shall be a twelve (12) month guarantee on all traffic signal work performed by the Contractor. Said twelve (12) month period shall commence from the date of Final Acceptance.

Materials shall be warranted for a minimum of one (1) year, except as otherwise noted in the project plans and specifications. The Contractor shall supply the County with all manufacturers' warranties covering material and parts.

At Final Acceptance, normal operation and maintenance of the traffic signal shall become the responsibility of the owner.

Unless otherwise specified, all bonding and grounding, excavation and backfilling, maintaining existing and temporary electrical systems, and field tests and turn-on shall not be paid for separately, but shall be included in the cost of the work.

END REVISION OF SECTION 614

**REVISION OF SECTION 614 -
TRAFFIC SIGNAL CONTROLLER**

Section 614 of the Standard Specifications is hereby revised for this project as follows:

Subsection 614.08 (b) shall be replaced with the following:

The traffic signal controller shall consist of a complete electrical mechanism to control the operation of traffic control signals, including the timing mechanism and all necessary auxiliary equipment. Controllers shall be Econolite TS2 Type 2 controllers or Econolite equivalent. All equipment furnished shall be the manufacturers' latest, current production model, complete with all standard accessories, tested and delivered by domestic manufacture who is regularly engaged in the construction of such equipment. Each cabinet shall be furnished with full eight phase capability (loop amps, load switch, etc.) regardless of specific intersection design with the exception of mid-block and fire signals.

INTERSECTION PHASING

Intersection phasing shall be as defined in the table below regardless of direction of the coordinated vehicular movements. When intersection phasing defined in the plans and/or project specials conflicts with that defined here within, the Engineer shall make final determination as to the intersection phasing.

Controller Phase	Vehicular Movement
1	Northbound Left Turn
2	Southbound
3	Eastbound Left Turn
4	Westbound
5	Southbound Left Turn
6	Northbound
7	Westbound Left Turn
8	Eastbound

ON-STREET MASTER CONTROLLER

An Econolite ASC2/M On-Street Master Controller shall be provided when called for in the plans and specifications and whenever a cabinet is designated as a master cabinet.

A telemetry interface harness and interface panel shall be supplied with each On-Street Master Controller for enabling of communications between the On-Street Master Controller with all associated local controllers.

The On-Street Master Controller shall include all required FSK and/or RS232 telemetry modules required for communications to associated local controllers.

An external 56K Hayes-compatible dial-up modem, RJ11 phone jack, and modem cable shall be included and installed in the master cabinet when called for in the plans and specifications and whenever a cabinet is designated as a master cabinet.

When called for in the plans and specifications and whenever a cabinet is designated as a master cabinet, the cabinet shall include an ASC-2/M power cord to power the on-street master controller. The power cord shall be attached through the cabinet's power bus; power via a supplied power outlet shall not be permitted.

**REVISION OF SECTION 614 -
TRAFFIC SIGNAL CONTROLLER**

Subsection 614.13 shall include the following:

The traffic signal controller shall be paid for on a unit basis and shall include all labor, equipment and materials necessary to install the item complete-in-place. The on-street master controller shall be paid for under the "Traffic Signal Controller" pay item.

The on-street master controller shall be paid for on a unit basis and shall include all labor, equipment and materials necessary to install the item complete-in-place, including all cabinet accessories internal to the cabinet. The on-street master controller shall be paid for under the "Traffic Signal Controller (Master)" pay item.

Subsection 614.14 shall include the following:

Payment will be made under:

Pay Item	Pay Unit
Traffic Signal Controller	Each
Traffic Signal Controller (Master)	Each

END REVISION OF SECTION 614

**REVISION OF SECTION 614 -
TRAFFIC SIGNAL CONTROLLER CABINET**

Section 614 of the Standard Specifications is hereby revised for this project as follows:

Subsection 614.08 (c) shall be replaced with the following:

This specification sets forth the minimum requirements for a TS2 Type 1 traffic control modular cabinet assembly. The cabinet assembly shall meet, as a minimum, all applicable sections of the NEMA Standard Publication No. TS2-2003 v. 2.06. Where differences occur, this specification shall govern.

All controller cabinets shall be "P44" type cabinets and shall meet or exceed size 6 cabinet specifications except for use at two phase pedestrian crossings and/or fire signals. Pedestrian crossing and fire signal controller cabinets shall be "G" type cabinets and shall meet or exceed size 3 cabinet specifications unless otherwise called for on the plans.

A controller shall consist of a complete electrical mechanism to control the operation of traffic control signals, including the timing mechanism and all necessary auxiliary equipment. Controllers shall be Econolite TS2 Type 2 controllers or Econolite equivalent. All equipment furnished shall be the manufacturers' latest, current production model, complete with all standard accessories, tested and delivered by domestic manufacture who is regularly engaged in the construction of such equipment. Each cabinet shall be furnished with full eight phase capability (loop amps, load switch, etc.) regardless of specific intersection design with the exception of mid-block and fire signals.

All electrical conduits running to the control cabinet shall enter from the bottom only to accept conduit, except as noted on the plans. No holes shall be drilled in any part of the cabinet other than the bottom, unless otherwise called for on the plans.

All controller cabinets and control equipment shall be factory wired, ready for operation. Contractor shall test cabinet and controller in his shop prior to installation. Field work will be limited to placing cabinets and equipment and the connecting of field wiring to field terminal strips. All cabinet wiring shall be neat and firm. The controller cabinet shall include a ground rod as shown in the County Standard Details and shall be considered incidental to the Traffic Signal Controller Cabinet pay item.

Controller cabinets shall be furnished with all mounting hardware.

Power protection devices shall include the main AC+ power circuit breaker, radio interference suppressors, and lightning and surge protectors. These devices shall be in addition to any protective devices furnished with the controller and auxiliary equipment housed within the cabinet and shall be provided on the load side of the circuit breakers. All devices shall be mounted to the interior wall or the cabinet in the approved manner.

All controller cabinets shall be equipped for and wired for two Opticom card rack mounted Global Traffic Technologies (GTT) Model 752 phase selectors. The phase selector cards, field wiring, and detectors shall not be supplied, unless called for in the Bid Schedule.

Where cabinets are designated as "Install Only" items, the Contractor shall be responsible for picking up the cabinet at the Adams County Public Works at 4955 East 74th Ave., Commerce City, Colorado 80022, bench-testing the cabinet, delivering the cabinet to the jobsite, and prepping and installing the cabinet per the Plans and Specifications.

-2-
**REVISION OF SECTION 614
TRAFFIC SIGNAL CONTROLLER CABINET**

CABINET DESIGN AND CONSTRUCTION

The cabinet shall be constructed from type 5052-H32 aluminum with a minimum thickness of 0.125 inches.

The cabinet shall be designed and manufactured with materials that will allow rigid mounting, whether intended for pole, base or pedestal mounting. The cabinet must not flex on its base.

Controller cabinet bases shall be fiberglass type, sized to match with the controller cabinet, and set with approximately 50% of height extending below grade and 50% extending above grade.

Controller cabinet bases shall be set on a twelve (12) inch deep bed of crushed rock. The interior of the base shall be filled to grade level with crushed rock.

Conduits within the controller cabinet base shall extend a minimum of 6" above the crushed rock. Conduits shall be installed in such fashion as to prevent undue bend stress on cables being fed into the cabinet through these conduits.

A rain channel shall be incorporated into the design of the main door opening to prevent liquids from entering the enclosure. The cabinet door opening must be a minimum of 80 percent of the front surface of the cabinet. A stiffener plate shall be welded across the inside of the main door to prevent flexing.

The top of the cabinet shall incorporate a 1-inch slope toward the rear to prevent rain accumulation. The cabinet shall be supplied with a natural aluminum finish. Sufficient care shall be taken in handling to ensure that scratches are minimized. All surfaces shall be free from weld flash. Welds shall be smooth, neatly formed, free from cracks, blowholes and other irregularities. All sharp edges shall be ground smooth.

All seams shall be sealed with RTV sealant or equivalent material on the interior of the cabinet.

All cabinets shall be supplied with a minimum of one removable shelf manufactured from 5052-H32 aluminum to hold the controller and MMU units. A second shelf also manufactured from 5052-H32 aluminum shall be installed toward the top of the cabinet. This removable shelf shall hold the detector card rack with ample room for the power supply. Shelves shall be a minimum of 10 inches deep.

The shelves shall have horizontal slots at the rear and vertical slots at the front of the turned down side flange. The shelves shall be installed by first inserting the rear edge of the shelf on the cabinet rear sidewall mounting studs, then lowering the shelf on the front sidewall mounting studs. The shelves shall be held in place by a nylon tie-wrap inserted through holes on the front edge of the shelf and around the front sidewall mounting studs.

The front edge of the shelves shall have holes punched every 6 inches to accommodate tie-wrapping of cables/harnesses.

A minimum of one set of vertical "C" channels shall be mounted on each interior wall of the cabinet for the purpose of mounting the cabinet components. The channels shall accommodate spring mounted nuts or studs. All mounting rails shall extend to within 7 inches of the top and

**REVISION OF SECTION 614
TRAFFIC SIGNAL CONTROLLER CABINET**

bottom of the cabinet. Sidewall rail spacing shall be 7.88 inches center-to-center. Rear wall rail spacing shall be 18.50 inches center-to-center.

The main door and police door-in-door shall close against a weatherproof and dust-proof, closed-cell neoprene gasket seal. The gasket material for the main door shall be a minimum of 0.250 inches thick by 1.00 inch wide. The gasket material for the police door shall be a minimum of 0.250 inches thick by 0.500 inches wide. The gaskets shall be permanently bonded to the cabinet.

The lower section of the cabinet shall be equipped with a louvered air entrance. The air inlet shall be large enough to allow sufficient air flow per the rated fan capacity. Louvers must satisfy the NEMA rod entry test for 3R ventilated enclosures. A non-corrosive, vermin and insect proof, removable air filter shall be secured to the air entrance. The filter shall fit snugly against the cabinet door wall.

The roof of the cabinet shall incorporate an exhaust plenum with a vent screen. Perforations in the vent screen shall not exceed 0.125 inches in diameter.

The main door on a size 3 or larger cabinet shall be equipped with a three-point latching mechanism.

The handle on the main door of a size 4 or larger cabinet shall utilize a shank of 5/8 inches minimum diameter. The handle on the main door of a size 3 cabinet shall utilize a shank of 7/16 inches minimum diameter. The handle shall include a hasp for the attachment of an optional padlock. The cabinet door handle shall rotate counter-clockwise to open. The handle shall not extend beyond the perimeter of the main door at any time. The lock assembly shall be positioned so that the handle shall not cause any interference with the key when opening the cabinet door.

The main door hinge shall be a one-piece, continuous piano hinge with a stainless steel pin running the entire length of the door. The hinge shall be attached in such a manner that no rivets or bolts are exposed.

The main door of a size 5 or larger cabinet shall include a mechanism capable of holding the door open at approximately 90, 125, and 150 degrees under windy conditions. Manual placement of the mechanism shall not be required by field personnel. The main door of a size 2, 3, or 4 cabinet shall include a mechanism capable of holding the door open at approximately 90 and 150 degrees under windy conditions.

The main door shall be equipped with a Corbin tumbler lock number 1548-1 or exact equivalent. A Minimum of two keys shall be supplied.

The police door-in-door shall be provided with a treasury type lock Corbin number R357SGS or exact equivalent. A minimum of two keys shall be supplied.

All base mounted cabinets require anchor bolts to properly secure the cabinet to its base. The cabinet flange for securing the anchor bolts shall not protrude outward from the bottom of the cabinet. When a size 3, 4, or 5 cabinet is base mounted, two anchor bolts shall be required for proper installation. Size 6 and 7 cabinets, four anchor bolts shall be required for proper installation.

**REVISION OF SECTION 614
TRAFFIC SIGNAL CONTROLLER CABINET**

Each cabinet shall be of sufficient size to accommodate all equipment. At a minimum, cabinet sizes are as follows:

- Size 1 cabinets – 24” H x 16” W x 12” D
- Size 2 cabinets – 32” H x 20” W x 14” D
- Size 3 cabinets – 40” H x 24” W x 15” D; (Pole Mount “G” Cabinet)
- Size 4 cabinets – 46” H x 24” W x 16” D
- Size 5 cabinets – 48” H x 30” W x 16” D
- Size 6 cabinets – 52” H x 44” W x 24” D; (“P44” Cabinet)
- Size 7 cabinets – 72” H x 44” W x 24” D

TERMINALS AND FACILITIES/MAIN PANEL DESIGN AND CONSTRUCTION

The main panel shall be constructed from 5052-H32 brushed aluminum of 0.125 inches minimum thickness and installed so as to minimize flexing when plug-in components are installed.

All 8-, 12- and 16-position main panels are provided with a mounting mechanism which allows easy access to all wiring on the rear of the panel without the removal of any cabinet shelves. Lowering or complete removal of the main panel can be accomplished by the use of simple hand tools.

The terminals and facilities shall be available as a minimum in the following configurations:

- | | |
|--------------------|--|
| Configuration #1 - | Four load switch sockets, two flash transfer relay sockets, one flasher socket, 1 BIU sockets (expandable to 2) with one BIU for each socket, one 8-channel detector rack with one BIU, and one Type-16 Malfunction Management Unit (MMU). |
| Configuration #2 - | Eight load switch sockets, four flash transfer relay sockets, one flasher socket, 1 BIU sockets (expandable to 2) with one BIU for each socket, one 8-channel detector rack with one BIU, and one Type-16 Malfunction Management Unit (MMU). |
| Configuration #3 - | Twelve load switch sockets, six flash transfer relay sockets, one flasher socket, 2 BIU sockets with one BIU for each socket, one 16-channel detector rack with one BIU, and one Type-16 Malfunction Management Unit (MMU). |
| Configuration #4 - | Sixteen load switch sockets, six flash transfer relay sockets, one flasher socket, 2 BIU sockets with one BIU for each socket, one 16-channel detector rack with one BIU, and one Type-16 Malfunction Management Unit (MMU). |

All size 3 cabinets (“G” Cabinets) shall, at a minimum, adhere to Configuration # 1. Where necessary, the power panel may be incorporated into the back panel due to cabinet sizing constraints. All size 6 cabinets (“P44” Cabinets) shall, at a minimum, adhere to Configuration #3. All load switch and flash transfer relay socket reference designators shall be silk-screen labeled on the front and rear of the main panel to match drawing designations. Socket pins shall be marked for reference on the rear of the panel.

**REVISION OF SECTION 614
TRAFFIC SIGNAL CONTROLLER CABINET**

A maximum of eight load switch sockets may be positioned horizontally or stacked in two rows on the main panel. Main panels requiring more than eight load switch sockets shall be mounted in two horizontal rows.

All load switches shall be supported by a bracket, extending at least half the length of the load switch.

The 4- and 8- load switch position main panels shall have all field wires contained within one or two row(s) of horizontally mounted terminal blocks.

The 12- and 16- load switch position main panels shall have all field wires contained on two rows of horizontally mounted terminal blocks. The upper row shall be wired for the pedestrian and overlap field terminations. The lower row shall be reserved for phase one through phase eight vehicle field terminations.

All field output circuits shall be terminated on a non-fused barrier type terminal block with a minimum rating of 10 amps.

All field input/output (I/O) terminals shall be identified by permanent alphanumeric labels. All labels shall use standard nomenclature per the NEMA TS2 specification.

It shall be possible to flash either the yellow or red indication on any vehicle movement and to change from one color indication to the other by use of a screwdriver.

Field termination blocks shall be wired to use four positions per vehicle or overlap phase (green, yellow, and red, flash). It shall not be necessary to de-buss field terminal blocks for flash programming.

The main panel shall contain at least one flasher socket (silk screen labeled) capable of operating a 15-amp, 2-pole, NEMA solid-state flasher. The flasher shall be supported by a bracket, extending at least half its length.

One RC network shall be wired in parallel with each group of three flash-transfer relays and any other relay coils.

All logic-level, NEMA-controller and Malfunction Management Unit input and output terminations on the main panel shall be permanently labeled. Cabinet prints shall identify the function of each terminal position.

At a minimum, three 20-position terminal blocks shall be provided at the top of the main panel to provide access to the controller unit's programmable and non-programmable I/O. Terminal blocks for DC signal interfacing shall have a number 6-32 x 7/32 inch screw as minimum.

-6-
**REVISION OF SECTION 614
TRAFFIC SIGNAL CONTROLLER CABINET**

All main panel wiring shall conform to the following wire size and color:

- Green/Walk load switch output – brown wire – 14 gauge
- Yellow load switch output – yellow wire – 14 gauge
- Red/Don't Walk load switch output – red wire – 14 gauge
- MMU (other than AC power) – violet wire – 22 gauge
- Controller I/O – blue wire – 22 gauge
- AC Line (power panel to – black wire main panel) – 8 / 10 gauge
- AC Line (main panel) – black wire – 10 gauge
- AC Neutral (power panel to – white wire main panel) – 8 / 10 gauge
- AC Neutral (main panel) – white wire – 10 gauge
- Earth ground (power panel) – green wire – 8 gauge
- Logic ground – gray wire – 22 gauge
- Flash programming – orange wire – 14 gauge
- Flash terminal – black wire red or yellow field terminal – 14 gauge

All wiring, 14 AWG and smaller, shall conform to MIL-W-16878/1, type B/N, 600V, 19-strand tinned copper. The wire shall have a minimum of 0.010 inches thick PVC insulation with clear nylon jacket and rated to 105 degrees Celsius. All 12 AWG and larger wire shall have UL listed THHN/THWN 90 degrees Celsius, 600V, 0.020 inches thick PVC insulation and clear nylon jacket.

Connecting cables shall be sleeved in a braided nylon mesh or poly-jacketed. The use of exposed tie-wraps or interwoven cables is unacceptable.

All Terminals and Facilities configurations shall be provided with BIU wiring assignments consistent with NEMA TS2-1998 specifications.

All Terminals and Facilities configurations shall be provided with sufficient RS-485 Port 1 communication cables to allow for the intended operation of that cabinet. Each communication cable connector shall be a 15-pin metal shell D subminiature type. The cable shall be a shielded cable suitable for RS-485 communications.

All main panels shall be pre-wired for a Type-16 Malfunction Management Unit.

All wiring shall be neat in appearance. All cabinet wiring shall be continuous from its point of origin to its termination point. Butt type connections/splices are not acceptable.

All connecting cables and wire runs shall be secured by mechanical clamps. Stick-on type clamps are not acceptable.

The grounding system in the cabinet shall be divided into three separate circuits (AC Neutral, Earth Ground, and Logic Ground). These ground circuits shall be connected together at a single point as outlined in the NEMA TS2 Standard.

The main panel shall incorporate a relay to remove +24 VDC from the common side of the load switches when the intersection is placed into mechanical flash. The relay shall have a momentary pushbutton to apply power to the load switch inputs for ease of troubleshooting.

**REVISION OF SECTION 614
TRAFFIC SIGNAL CONTROLLER CABINET**

All pedestrian push button inputs from the field to the controller shall be opto-isolated through the BIU and operate at 12 VAC.

All wire (size 16 AWG or smaller) at solder joints shall be hooked or looped around the eyelet or terminal block post prior to soldering to ensure circuit integrity. Lap joint soldering is not acceptable.

All required cabinet wiring and cabling shall be paid for under the wiring pay item.

POWER PANEL DESIGN AND CONSTRUCTION

The power panel shall be integrated into the main panel and be located on the lower right portion. The power panel shall be wired to provide the necessary filtered power to the load switches, flasher(s), and power bus assembly. The power components shall be equipped with a removable plastic front cover for technician protection. The design will allow a technician to access the main and auxiliary breakers without removing the protective front cover.

The power panel portion of the main panel shall include the following components:

- a. A minimum of a 40-amp main breaker for 12- or 16- position cabinets or a minimum of a 30-amp breaker for 4- or 8-position cabinets. This breaker shall supply power to the controller, MMU, signals, cabinet power supply and auxiliary panels. Breakers shall be at minimum, a thermal magnetic type, U.L. listed for HACR service, with a minimum of 10,000 amp interrupting capacity.
- b. A minimum of a 15-amp auxiliary breaker. This breaker shall supply power to the fan, light and GFI utility outlet.
- c. An EDCO model SHP-300-10 or exact approved equivalent surge arrester.
- d. A 50 amp, 125 VAC radio interference line filter.
- e. A normally-open, 60-amp, mercury contactor Mercury Industries, Inc. model 60NC-120A or exact equivalent.
- f. A minimum of 8-position neutral bus bar capable of connecting three #12 wires per position.
- g. A minimum of 6-position ground bus bar capable of connecting three #12 wires per position.
- h. A NEMA type 5-15R GFI utility outlet.
- i. A 4-position plug-in connector for wiring to the power bus assembly.

POWER BUS ASSEMBLY

The power bus assembly shall be manufactured from 0.090", 5052-H32 aluminum. It shall provide filtered power for the controller, malfunction management unit, cabinet power supply, and auxiliary equipment. It shall include the SDLC Bus connecting cables wired into a surface-mounted compression terminal block.

**REVISION OF SECTION 614
TRAFFIC SIGNAL CONTROLLER CABINET**

The power bus assembly shall house the following components:

- a. A minimum of three and a maximum of six power connectors.
- b. Two terminal strips to hardwire the power connectors.
- c. SDLC terminal block with pre-wired cables.

All cabinet equipment requiring filtered power to operate shall be connected to the power bus assembly by a Burndy connector # SMS12PDH1 or exact equivalent or hardwired directly to the supplied terminal blocks.

AUXILIARY CABINET EQUIPMENT

The cabinet shall be provided with a thermostatically controlled (adjustable between 80-150 degrees Fahrenheit) ventilation fan in the top of the cabinet plenum. The fan plate shall be removable with the use of simple hand tools for serviceability. A minimum of one exhaust fan shall be provided. The fan shall be a ball bearing type fan and shall be capable of drawing a minimum of 100 cubic feet of air per minute. The fan/thermostat assembly shall be connected to the power panel by a means of a 4 position plug-in cable.

At minimum, a 40-watt incandescent refrigerator lamp and socket mounted on an aluminum bracket shall be mounted in the cabinet to sufficiently illuminate the field terminals. The lamp shall be wired to a door-activated switch mounted near the top of the door.

Alternately, a 25-watt incandescent lamp mounted on a 14-inch flexible arm shall be included. The flexible arm shall be permanently mounted to the middle of the cabinet door. The lamp shall be wired to a door-activated switch mounted near the top of the door.

Alternately, a fluorescent lighting fixture shall be mounted on the inside top of the cabinet near the front edge. The fixture shall be rated to accommodate at minimum a F15T8 lamp operated from a normal power factor UL or ETL listed ballast. The lamp shall be wired to a door-activated switch mounted near the top of the door.

A resealable print pouch shall be mounted to the door of the cabinet. The pouch shall be of sufficient size to accommodate one complete set of cabinet prints.

A minimum of two sets of complete and accurate cabinet drawings shall be supplied with each cabinet.

A minimum of one set of manuals for the controller, Malfunction Management Unit and vehicle detector amplifiers shall be supplied with each cabinet.

CABINET TEST SWITCHES AND POLICE PANEL

A test switch panel shall be mounted on the inside of the main door. Momentary test push buttons for all vehicle and pedestrian inputs to the controller are not required. The TS2 controller to be provided with the cabinet assembly shall provide vehicular and pedestrian call inputs from its keyboard while in the standard status display. The test switch panel shall provide as a minimum the following:

**REVISION OF SECTION 614
TRAFFIC SIGNAL CONTROLLER CABINET**

AUTO/FLASH SWITCH: When in the flash position, power shall be maintained to the controller and the intersection shall be placed in flash. The controller shall not be stop timed when in flash. Wired according to NEMA TS2 – 2003 the MMU forces the controller to initiate the start-up sequence when exiting flash.

STOP TIME SWITCH: When applied, the controller shall be stop timed in the current interval.

CONTROL EQUIPMENT POWER ON/OFF: This switch shall control the controller, MMU, and cabinet power supply AC power.

The police door switch panel shall contain the following:

SIGNALS ON/OFF SWITCH: In the OFF position, power shall be removed from signal heads in the intersection. The controller shall continue to operate. When in the OFF position, the MMU shall not conflict or require reset.

AUTO/FLASH SWITCH: When in the flash position, power shall be maintained to the controller and the intersection shall be placed in flash. The controller shall not be stop timed when in flash. Wired according to NEMA TS2 – 2003 the MMU forces the controller to initiate the start-up sequence when exiting flash.

AUTO/MANUAL SWITCH: Cabinet wiring shall include an AUTO/MANUAL switch and provisions for a momentary push button or hand cord. The AUTO/MANUAL push button or hand cord shall not be provided unless it is called for in the signal plans and specifications.

COORD/FREE SWITCH: Cabinet wiring shall include provisions for COORD/FREE switch.

The COORD/FREE switch shall not be provided unless it is called for in the signal plans and specifications.

All toggle type switches shall be heavy duty and rated 15 amps minimum. Single- or double-pole switches may be provided, as required.

Any exposed terminals or switch solder points shall be covered with a non-flexible shield to prevent accidental contact.

All switch functions must be permanently and clearly labeled.

All wire routed to the police door-in-door and test switch push button panel shall be adequately protected against damage from repetitive opening and closing of the main door.

All test switch panel wiring shall be connected to the main panel via a 36-pin Burndy connector # SMS36R1, or exact equivalent.

-10-
**REVISION OF SECTION 614
TRAFFIC SIGNAL CONTROLLER CABINET**

CONTROLLER TELEMETRY INTERFACE PANEL

A telemetry interface harness and interface panel shall be supplied with each cabinet assembly. The harness shall be a minimum of 6 feet long and shall consist of two twisted shielded pairs, 22 AWG wire with drain wire in an overall jacket, terminated to a 9-pin "D" type connector at one end. The pin out of the 9-pin connector shall be in exact accordance with the NEMA TS2 Standard. The opposite end of the harness shall be terminated on a 10-position EDCO PCB-1B or exact equal lightning protection socket base.

All terminal block designations and peripheral board-mounted components shall be labeled as to their number and function and shall correspond to the cabinet wiring diagrams.

The following signals shall be accessible from the telemetry interface panel:

- Local controller command lines 1 & 2.
- Local controller read back lines 1 & 2.
- Master controller command lines 1 & 2.
- Master controller read back lines 1 & 2.
- Earth grounds.

A socket mounted communication line transient protection device shall be supplied with the telemetry interface panel. The device shall be an EDCO model PC642C-008D or exact approved equivalent. The transient protection device shall be wired in series with the telemetry communication circuit.

Communication line impedance shall be matched to the transmitter output impedance to minimize noise on the communication lines. The panel shall allow connection of a 620 ohm resistor across the command and read back lines, where necessary.

AUXILIARY DEVICES

Load Switches

Load switches shall be solid state and shall conform to the requirements of Section 6.2 of the NEMA TS2 Standard.

Signal load switches shall have a minimum rating of 10 amperes at 120 VAC for an incandescent lamp load.

The front of the load switches shall be provided with three indicators to show the input signal from the controller to the load switches.

Load switches shall be dedicated per phase. The use of load switches for other partial phases is not acceptable.

The full complement of load switches shall be supplied with each cabinet to allow for maximum phase utilization for which the cabinet is designed.

-11-
**REVISION OF SECTION 614
TRAFFIC SIGNAL CONTROLLER CABINET**

Flashers

The flasher shall be solid state and shall conform to the requirements of section 6.3 of the NEMA TS2 Standard.

Flashing of field circuits for the purpose of intersection flash shall be accomplished by a separate flasher.

The flasher shall be rated at 15 amperes, double pole with a nominal flash rate of 60 FPM.

Flash Transfer Relays

All flash transfer relays shall meet the requirements of Section 6.4 of the NEMA TS2 Standard.

The coil of the flash transfer relay must be de-energized for flash operation.

The full complement of relays shall be supplied with each cabinet to allow for maximum phase utilization for which the cabinet is designed.

Malfunction Management Units

Each cabinet assembly shall be supplied with one Malfunction Management Unit (MMU) as defined by the requirements of Section 4 of the NEMA TS2 Standard.

Malfunction Management Units shall be a Type 16. The MMU shall be an Econolite Control Products, Inc. Model MMU-16E, EDI Model MMU-16E, or approved equal.

Bus Interface Units

All Bus Interface Units (BIUs) shall meet the requirements of Section 8 of the NEMA TS2 Standard.

The full complement of Bus Interface Units shall be supplied with each cabinet to allow for maximum phase and function utilization for which the cabinet is designed.

Each Bus Interface Unit shall include power on, transmit and valid data indicators. All indicators shall be LEDs.

Cabinet Power Supply

The cabinet power supply shall meet the requirements of Section 5.3.5 of the NEMA TS2 Standard.

The cabinet power supply shall provide LED indicators for the line frequency, 12 VDC, 12 VAC, and 24 VDC outputs.

The cabinet power supply shall provide (on the front panel) jack plugs for access to the +24 VDC for test purposes.

One cabinet power supply shall be supplied with each cabinet assembly, and shall be wired directly to the Power Bus Assembly via a Burndy 12-position # SMS12PDH1 connector or exact equivalent.

-12-
**REVISION OF SECTION 614
TRAFFIC SIGNAL CONTROLLER CABINET**

TESTING AND WARRANTY

Testing

Each controller and cabinet assembly shall be tested as a complete entity under signal load for a minimum of 48 hours.

Each assembly shall be delivered with a signed document detailing the cabinet final tests performed.

The cabinet shall be assembled and tested by the controller manufacturer or authorized local distributor to ensure proper component integration and operation.

Warranty

The controller and Malfunction Management Unit shall be warranted by the manufacturer against mechanical and electrical defects for a minimum period of 2 years from date of shipment. The manufacturer's warranty shall be supplied in writing with each cabinet and controller. Second party extended warranties are not acceptable.

The cabinet assembly and all other components shall be warranted for a period of one year from date of shipment.

Any defects shall be corrected by the manufacturer or supplier at no cost to the owner.

Subsection 614.08 (l) shall be replaced with the following:

VEHICLE DETECTION

A minimum of one vehicle detector amplifier rack shall be provided in each cabinet. Detector racks shall be available in two configurations. These configurations shall be integrated on the top left portion of the main panel.

Wiring from the main panel to the test panel shall be connected to the switch panel via a 24-pin Burndy connector # SMS24R1, or exact equivalent.

- Configuration #1 - Shall support up to eight channels of loop detection (either four 2 channel detectors or two 4 channel detectors), two 2-channel preemption devices, and one BIU. This configuration shall be included as a standard on the 8 position main panel assembly.
- Configuration #2 - Shall support up to 16 channels of loop detection (either eight 2 channel detectors or four 4 channel detectors), two 2-channel preemption devices and one BIU. This configuration shall be included as a standard on the 12 or 16 position main panel assembly.

All size 3 cabinets ("G" Cabinets) shall adhere to Configuration # 1. All size 6 cabinets ("P44" Cabinets) shall adhere to Configuration #3. Detector rack BIU mounting shall be an integral part of the detector rack.

**REVISION OF SECTION 614
TRAFFIC SIGNAL CONTROLLER CABINET**

All BIU rack connectors shall have jumper address pins corresponding to the requirements of the TS2 specification. The jumpers may be moved to change the address of any individual rack.

These address pins shall control the BIU mode of operation. BIUs shall be capable of being interchanged with no additional programming.

Each cabinet shall contain detector interface panels for the purpose of connecting field loops and vehicle detector amplifiers. The panels shall be manufactured from FR4 G10 fiberglass, 0.062" thick, with a minimum of 2 oz. of copper for all traces.

One 8-position interface panel shall be provided for an 8-channel rack cabinet and one 16-position interface panel shall be provided for a 16-channel rack cabinet. The interface panel shall be secured to a mounting plate and attached to the left sidewall of the cabinet.

Each interface panel shall allow for the connection of eight or sixteen independent field loops. A ground bus terminal shall be provided between each loop pair terminal to provide a termination for the loop lead-in cable ground wire.

Each interface panel shall provide a 10-position terminal block to terminate the field wires for up to two 2-channel preemption devices.

Lightning protection device mounting holes shall be provided to accommodate an Edco SRA-16C, or Edco SRA-6, or Edco LCA-6, or a varistor lightning protection device. Lightning protection devices shall not be provided unless specifically called for in the special provisions of this specification.

A cable consisting of 20 AWG twisted pair wires shall be provided to enable connection to and from the panel to the detector rack. The twisted pair wires shall be color coded red and white wire.

All termination points shall be identified by a unique number and silk screened on the panel.

Each detector rack shall accommodate rack mountable preemption devices such as EMTRAC or Opticom.

Each detector rack shall be powered by the cabinet power supply and be connected to the power bus assembly by means of a Burndy connector # SMS12PDH1.

Subsection 614.13 shall include the following:

The Traffic Signal Controller Cabinet shall include all labor, equipment and materials necessary to install the item complete-in-place, including all cabinet accessories internal to the cabinet. Controller cabinet bases shall be as shown in the County Standard Plans, and shall be considered incidental to the Traffic Signal Controller Cabinet pay item.

Subsection 614.14 shall include the following:

Pay Item	Pay Unit
Traffic Signal Controller Cabinet	Each

END REVISION OF SECTION 614

REVISION OF SECTION 614 – TRAFFIC SIGNAL POLES

Section 614 of the Standard Specifications is hereby revised for this project as follows:

Subsection 614.08 (g) shall include the following:

Traffic signal poles, mast arms, and luminaire arms shall follow all of the requirements outlined in the Colorado Department of Transportation (CDOT) Standard Plans. Unless otherwise noted, traffic signal poles, mast arms and foundation design shall adhere to requirements as follows:

- Except as noted on the plans, traffic signal poles with mast arms up to and including 55 feet shall use CDOT Standard Plan No. S-614-40A, Sheets 1 through 5.
- Traffic signal poles with mast arms exceeding 55 feet shall follow the requirements of CDOT Standard Plan No. S-614-40, Sheets 2 through 7.
- Traffic signal span wire poles and traffic signal pedestal poles shall follow the requirements shown in the Adams County Standard Signal Details.
- Traffic signal poles with school flasher assemblies shall follow the requirements shown in the Adams County Standard Signal Details.

Traffic signal poles, mast arms, luminaire arms, pedestal poles, and span wire poles shall be wrapped for shipping from the factory in heavy duty paper or plastic to protect them from scratches and abrasions in transit. Poles shall be handled in a manner that will preserve the overall appearance and prevent damage to the coating. The use of chains or cables for loading, unloading, or installing is prohibited. Only 3/4 inch diameter or larger nonabrasive nylon rope or equivalent nylon belting will be used. Adequate hold-downs and appropriate blocking shall be utilized for shipping to prevent load movement and damage to the outer coating in transit.

Traffic signal poles, mast arms, luminaire arms, pedestal poles, and span wire poles shall be galvanized as per ASTM A123 and A153. Prior to the installation of traffic poles, mast arms, and/or luminaire arms, the Contractor shall wipe clean the outer surfaces. All accessible interior surfaces of signal poles shall also be galvanized per ASTM A123 and A153.

Any surface areas damaged during handling or installation shall be touched up immediately. Nicks and abrasions greater than 1/8 inch deep shall be spray painted with zinc rich paint (greater than 90%) that matches the galvanized finish, such as Brite Products Brite Zinc Galvanizing Compound. The manufacturer's application instructions shall be followed.

All ferrous mounting hardware and weatherheads shall be either galvanized, cadmium plated, or made of stainless steel to resist corrosion. Payment for these items shall be incidental to the pay item to which the miscellaneous hardware item is attached.

Specialty traffic signal poles, of nostalgia design or other, and which do not meet these specifications, shall only be installed with approval from the Engineer.

SPAN WIRE POLE

Span wire poles and cables shall be designated to meet the structural requirements given in the latest edition of "Standard Specifications for Structural Support for Highway Signs, Luminaires and Traffic Signals", published by AASHTO, for a wind velocity of 90 MPH. The minimum pole weights and span wire cable rating given in the standard details shall be increased as necessary in accordance with the AASHTO requirements. All span wire poles shall be steel.

-2-
**REVISION OF SECTION 614 –
TRAFFIC SIGNAL POLES**

Span wire poles may be seamless, or may be fabricated as one piece without transverse joints or welds and with only one longitudinal seam which shall be either continuously welded and ground, or rolled flush.

Span wire cable shall be seven wire stranded, common galvanized, and utilities grade. The cable shall have a minimum wire diameter of 3/8 inch, and shall be rated at 13,000 pounds minimum. Tether cable shall have a maximum diameter of 1/4 inch and shall be stranded, galvanized steel. Both span wire cable and tether cable shall be incidental to the span wire pay item.

PEDESTAL POLE

Pedestal poles shall be designed to meet the structural requirement given in the latest edition of "Standard Specifications for Structural Support for Highway Signs, Luminaires and Traffic Signals", published by AASHTO, for a wind velocity of 90 MPH. Unless modified by a structural analysis, the pole shall be Schedule 40 galvanized steel. The pole base shall be frangible. The pedestal pole shall be hot dipped galvanized per ASTM A123 and A153, equivalent to 2 oz. per square foot, inside and out.

Subsection 614.13 shall include the following:

Traffic signal pole (steel), traffic signal-light pole (steel), traffic signal span wire pole, and traffic signal pedestal pole shall be measured and paid for per unit count and shall include all labor, equipment, and materials necessary to install the item complete-in-place. Unless otherwise noted in the plans, the cost of the traffic signal mast arm shall be incidental to the traffic signal pole, or traffic signal-light pole as appropriate.

Span wire cable shall be measured and paid for per unit count and shall include all labor, equipment, and materials necessary to install both the span wire cable and tether cable complete-in-place. Span wire cable shall be paid for under the "Span Wire Cable" pay item.

Traffic signal pole and traffic signal-light pole foundations shall be paid for separately as "Drilled Caissons", and meet all of the requirements outlined in the CDOT Standard Plans No. S-614-40, or CDOT Standard Plans No. S-614-40A, as applicable, and Section 503. Traffic signal poles and traffic signal-light poles with school flasher assemblies shall follow the requirements of the Adams County Standard Details. Traffic signal pole and traffic signal-light pole foundations with school flasher assemblies shall be paid for separately as "Drilled Caissons", and meet all of the requirements outlined in the Adams County Standard Details. Traffic Signal Pedestal Pole foundations and Traffic Signal Span Wire Pole foundations shall be included in the cost of the pole.

Subsection 614.14 shall include the following:

Pay Item	Pay Unit
Traffic Signal Pole (Steel)	Each
Traffic Signal-Light Pole (Steel),	Each
Traffic Signal Span Wire Pole	Each
Traffic Signal Pedestal Pole Steel	Each
Span Wire Cable	Each

Payment includes all labor, equipment and materials necessary to complete the work.

END REVISION OF SECTION 614

**REVISION OF SECTION 614 –
TRAFFIC SIGNAL FACE**

Section 614 of the Standard Specification is hereby revised for this project as follows:

Subsection 614.08 (h) Delete the third paragraph and replace with the following:

All vehicular traffic signal heads shall be 100% polycarbonate, colored black, with black, detachable, tunnel visors. Standard signal heads shall be Eagle Signal Corporation, McCain, or approved equal.

LED indications shall be furnished for all indications unless defined otherwise in the plans and shall include red ball, yellow ball, green ball, and arrow indications. All LED indications shall be warranted for a minimum of seven years by the manufacturer. Traffic LED indications shall be Gelcore, Series DR6 (RX11), or approved equal, with a 12" diameter displays unless otherwise noted.

When incandescent bulbs are defined in the plans, traffic signal bulbs shall be General Electric, Durotest, Phillips, or Engineer approved alternate. They shall be 116 watt, 130 volt for all 12-inch indications. Bulbs shall be 69 watt, 130 volt, for all 8-inch and pedestrian indications.

All signal head locations shall be approved by the Engineer in the field.

All back plates shall be installed on all mast arm mounted and/or span wire mounted traffic signal heads, black in color, and of the louvered design to allow wind passage. Back plates shall not be mounted on side-of-pole mounted traffic signal heads.

Astro-brac or Sky-brac type mounting hardware shall be used to attach all traffic signal heads mounted on mast arms.

Industry standard span wire mounting hardware shall be used to attach the signal heads to both the span wire cable and messenger cable on a span wire type installation.

Side of pole traffic signal heads shall use industry standard side of pole hardware on both the top and bottom traffic signal head sections for mounting.

All Band-it material, including buckles, shall be 3/4" stainless steel.

During construction, traffic signal heads that have been installed but are not ready for actual electrical connection shall be bagged with a dark opaque material.

Subsection 614.13 shall include the following:

Traffic Signal Heads shall be paid for as Traffic Signal Face, with the number of indications as specified on the plans, and on a unit price basis that shall include all labor, equipment and materials necessary to install the item complete-in-place.

Subsection 614.14 shall include the following:

Pay Item	Pay Unit
Traffic Signal Face	Each

END REVISION OF SECTION 614

**REVISION OF SECTION 614 –
PEDESTRIAN SIGNAL FACE**

Section 614 of the Standard Specification is hereby revised for this project as follows:

Subsection 614.08 (h) Delete the third paragraph and replace with the following:

All pedestrian signal heads shall be single section, black, symbolized messages, and clam shell mounting. Standard pedestrian signal heads shall be as manufactured by Indicator Controls Corporation, or approved equal.

LED indications shall be furnished for all indications unless defined otherwise in the plans and shall include countdown pedestrian hand and walk-man indications. Pedestrian indications shall be of the "filled" type. Outlined hand and walk-man indications shall not be permitted. All LED indications shall be warranted for a minimum of seven years by the manufacturer. Pedestrian countdown LED indications shall be Gelcore Model PS7-CFF1-01A-18², or approved equal, with 16" displays, unless otherwise noted.

All pedestrian head locations shall be approved by the Engineer.

Industry standard span wire mounting hardware shall be used to attach the signal heads to both the span wire cable and messenger cable on a span wire type installation.

All Band-it material, including buckles, shall be 3/4" stainless steel.

Subsection 614.13 shall include the following:

Pedestrian signal heads shall be paid for as Pedestrian Signal Face (16), and Pedestrian Signal Face (16) (Countdown), and on a unit price basis that shall include all labor, equipment and materials necessary to install the item complete-in-place.

Subsection 614.14 shall include the following:

Pay Item	Pay Unit
Traffic Pedestrian Signal Face (16)	Each
Traffic Pedestrian Signal Face (16) (Countdown)	Each

END REVISION OF SECTION 614

REVISION OF SECTION 614 – PEDESTRIAN PUSH BUTTON

Section 614 of the Standard Specification is hereby revised for this project as follows:

Subsection 614.08 (f) shall include the following:

Pedestrian push button assemblies shall be Pelco model SE-2005-08 (ADA pedestrian push button), or approved equal. The button housing shall be black in color. A separate 9" W x 12" H decal sign, MUTCD Reference # R10-3b or R10-3d as applicable or approved equal shall be installed with each pedestrian push button or as directed by the Engineer. For countdown pedestrian signal heads, A separate 9" W x 15" H decal sign, MUTCD Reference # R10-3e or approved equal shall be installed with each pedestrian push button.

Push button locators shall only be used where specified in the plans, and may be considered by the Engineer on a per project basis. When push button locators are requested, this function shall be integrated as part of the pedestrian push button, the pedestrian push button shall be of the manufacturer and model number specified, and shall conform to Manual on Uniform Traffic Control Devices (MUTCD) requirements and all current ADA accessibility requirements.

Audible pedestrian indications shall only be used where specified in the plans, and may be considered by the Engineer on a per project basis. When audible pedestrian indications are requested, they may be of the manufacturer and model number specified, and shall conform to latest edition of the MUTCD requirements.

PEDESTRIAN PUSH BUTTON POLE

Pedestrian push button pole shall be as illustrated in the Adams County standard details, constructed of Schedule 40 galvanized steel. Pole base shall be frangible.

Subsection 614.13 shall include the following:

Pedestrian push buttons shall be paid for on a unit price basis and shall include all labor, equipment and materials necessary to install the item complete-in-place. Pedestrian push buttons shall be paid for under the "pedestrian push button" pay item.

Pedestrian push button poles shall be measured and paid for per unit count and shall include all labor, equipment, and materials necessary to install the item complete-in-place. Pedestrian push button poles shall be paid for under the "pedestrian push button pole" pay item.

When an audible pedestrian indication is requested and where this function is integrated within the pedestrian push button, the audible pedestrian indication costs shall be included in, as part of, the unit price of the "pedestrian push button" pay item.

Where the audible pedestrian indication function is not integrated within the pedestrian push button, audible pedestrian indications shall be paid for on a unit price basis and shall include all labor, equipment, and materials necessary to install the item complete-in-place. Audible pedestrian indications shall be paid for under the "audible pedestrian indication" pay item.

The cost of separate decal signs installed with each pedestrian push button shall be included in, as part of, the unit price of the "pedestrian push button", or "audible pedestrian indication" pay item, as applicable.

**REVISION OF SECTION 614 –
PEDESTRIAN PUSH BUTTON**

Subsection 614.14 shall include the following:

Pay Item	Pay Unit
Pedestrian Push Button	Each
Pedestrian Push Button Pole	Each
Audible Pedestrian Push Button	Each

Payment includes all labor, equipment and materials necessary to complete the work.

END REVISION OF SECTION 614

**REVISION OF SECTION 614
TRAFFIC SIGNAL VEHICLE DETECTOR AMPLIFIER**

Section 614 of the Standard Specifications is hereby revised as follows:

Subsection 614.08 (l) shall hereby include the following:

This specification defines the minimum design, operational, and performance requirements for a multiple channel, digital, self tuning inductive vehicle detector. Inductive vehicle detectors shall be card rack mounted, plug in type, and shall operate from an external 12-24 VDC power supply.

Inductance Vehicle Detectors shall be capable of operating within a TS1 or TS2-Type 1 cabinet.

Inductive vehicle detectors shall include a power indicator.

Inductive vehicle detectors shall have built-in protection against lightning induced and other transients.

Inductive vehicle detectors shall have all user programmed settings and vehicle detector gathered data stored in non-volatile memory.

Each inductive vehicle detector shall include two or four complete detector channels.

Each channel of the sensor unit shall automatically self tune to any loop and lead-in inductance from 20 to 2500 microhenries within 10 seconds after application or interruption of supply voltage. Units shall also track changes in loop/lead-in electrical characteristics, as might reasonably be expected to occur in undamaged loops properly installed in sound pavement, without producing false indications or changes in sensitivity.

Each channel shall have both detect and fault indicators.

All vehicle detection parameters shall be programmable separately for each channel. This includes the sensitivity, background adapt rate, recovery method, wash delay time, and wash adapt time.

Each channel at minimum shall be capable of a minimum of eight (8) pulse mode sensitivity levels, seven (7) presence mode sensitivity levels, off mode, and four (4) frequency settings.

Inductance vehicle detectors shall be hot-swappable.

Inductance vehicle detectors shall operate in temperatures between -29 degrees Fahrenheit and +165 degrees Fahrenheit with a humidity level of 0% to 95% (non-condensing).

When data storage capability is required per project plans and/or special provisions, inductance vehicle detectors shall meet these specifications, and all stored data shall be recoverable via built in RS232/RS485 communication ports.

Subsection 614.13 shall hereby be replaced with the following:

Inductance vehicle detectors shall be measured by the units installed and shall include all labor, equipment, and materials necessary to install the item complete-in-place. Inductance vehicle detectors shall be paid for under the pay item "Traffic Signal Vehicle Detector Amplifier (Loop Type)".

-2-
**REVISION OF SECTION 614
TRAFFIC SIGNAL VEHICLE DETECTOR AMPLIFIER**

Subsection 614.14 shall include the following:

Pay Item	Pay Unit
Traffic Signal Vehicle Detector Amplifier (Loop Type)	Each

END REVISION OF SECTION 614

**REVISION OF SECTION 614
LOOP DETECTOR WIRE**

Section 614 of the Standard Specifications is hereby revised as follows:

Subsection 614.08 (k) shall hereby include the following:

Detector loops shall be installed in accordance with these specifications, the construction plans, and the County Standard Details.

Each individual detector loop is to be spliced to a lead-in cable within a pull box as specified on the plans, and each loop shall consist of one continuous wire, without splicing, to this point. Any required series or parallel connections are to be completed in the pull box.

All detector loops shall have a tag attached to the leading clockwise lead of the loop. This tag shall be marked to indicate the relative location of the loop. This marking shall correspond directly to the phase designations in the Plans.

Detector loop roadway cuts, when required, shall be 3/8-inch in width and of sufficient depth to provide a minimum of 2-inch of sealant above the wire.

Detector loop roadway cuts where required shall be sealed to the surface level of the original roadway with "Gold Label Flex," "3-M Brand model Black 5000", "Bondo No. E-709", or approved equal. ("Bondo No. P-606" is not approved). This sealer is to be used whether or not the roadway is to be overlaid.

Detector loop installations larger than 6-foot x 6-foot shall be of a quadrapole (2-4-2) design, according to the Plans. Duct type loop wire, IMSA 51-5-1984, shall be used for all loops.

Where the detector loop lead enters or resides in a pull box or conduit, the two associated loop lead wires shall be twisted together in a clockwise direction with a twist rate of 10-12 twists per foot.

At a minimum, three (3) feet of twisted loop lead shall be left in the pull box where splicing is to occur.

Subsection 614.13 shall hereby be replaced with the following:

Detector loops shall be paid for on a unit price basis including loop wire, saw cutting, and sealant for a complete installation to the splice point pull box. Detector loops shall be paid for under the pay item "loop detector wire".

Subsection 614.14 shall include the following:

Pay Item	Pay Unit
Loop Detector Wire	Each

END REVISION OF SECTION 614

**REVISION OF SECTION 614 -
FIRE PREEMPTION UNIT AND TIMER**

Section 614 of the Standard Specifications is hereby revised for this project as follows:

Subsection 614.08 shall include the following:

Fire Preemption Unit. The Fire Preemption Unit shall consist of Global Traffic Technologies (GTT) Opticom phase selectors and detectors shall be of the most current model, or as specified herein. Opticom Detectors shall be installed as specified in the plans and may include model numbers 711, 721, and/or 722. Opticom Phase Selectors shall be model number 752.

Subsection 614.13 shall include the following:

Fire preemption units shall include both the Opticom phase selectors and detectors, and shall include all labor, equipment and materials necessary to install the items complete-in-place. Fire Preemption Unit and Timer shall be measured and paid by the number of intersections at which the system is installed. The item shall include all labor, materials, and ancillary hardware required to provide a fully functioning system to the satisfaction of the Engineer.

Subsection 614.14 shall include the following:

Pay Item	Pay Unit
Fire Preemption Unit and Timer	Each

END REVISION OF SECTION 614

**REVISION OF SECTION 614
INTERSECTION DETECTOR SYSTEM (CAMERA)**

Section 614 of the Standard Specifications is hereby revised as follows:

Subsection 614.08 (l) shall hereby include the following:

Video detection systems shall consist of video cameras, an isolation amplifier for video cabling, an automatic control unit (ACU) and a pointing device. The system shall detect vehicles on a roadway using only video images of vehicle traffic and shall be an Econolite, Traficon, or approved equal.

The system shall include software that detects vehicles in multiple lanes using only the video image. Detection zones shall be defined using only a video menu and a pointing device to place the zones on a video image. Up to twenty four (24) detection zones per camera shall be available.

The camera(s) supplied shall be compatible with the video detection system and shall be mounted on the luminaire davit when luminaire davit is present, mast arm when luminaire davit is not present, or other location as defined on the plans or as directed by the Engineer. The camera shall view approaching vehicles at a distance not to exceed 350 feet for reliable detection.

The camera shall be housed in an environmentally sealed enclosure and shall be equipped with a sun shield that prevents sunlight from directly entering the lens. The camera shall be less than 6 inches in diameter, less than 26 inches long and shall weight less than 12 pounds when the camera and lens are mounted inside the enclosure.

The camera enclosure shall include all required environmental controls as defined by the camera manufacturer and may include a thermostatically controlled heater and/or fan to assure proper operation of the lens iris at both low and high temperatures, and prevent moisture condensation of the optical faceplate of the enclosure.

When a variable focal length lens with variable focus control is supplied as part of the camera, the lens shall be adjusted to suite the site geometry without opening up the camera housing.

When coaxial cable to use between the camera and the cabinet, coax cable shall be a 75 ohm, precision video cable with 20 gauge solid bare copper conductor (9.9 ohms/M), solid polyethylene insulating dielectric, 98" (min) tinned copper double-braided shield and black polyethylene outer covering. The signal attenuation shall not exceed 0.78 dB per 100 feet at 10MHz. Nominal outside diameter is 0.304 inches. This cable shall be suitable for installation in conduit or overhead appropriate span wire. BNC plug connectors shall be used at both the camera and cabinet ends. The coax cable, BNC connectors, and crimping tool shall be of an approved type by the supplier of the video detection system, and the manufacturer's instructions must be followed to insure proper connection.

Control and other cables required for installation, setup, and operation of the camera and/or video detection system are required, they shall be of the size and type required per manufacturer's specifications and the National Electric Codes. Control cables shall terminate within the controller cabinet.

The power cable shall be 16 AWG three conductor cable. The cabling shall comply with local and National Electric Codes.

**REVISION OF SECTION 614
INTERSECTION DETECTOR SYSTEM (CAMERA)**

The complete video detection system shall be warranted to be free of defects in material and workmanship for a period of not less than two years from the date of final acceptance and warranty initiation. During the warranty period, the Contractor shall be responsible for the repair or replacement, at no charge to the County, of any product of the video detection system which fails to operate properly with the exception of failures as a result of vandalism, accident, and/or act of God.

Subsection 614.13 shall hereby include the following:

The video detection system shall be paid for on the basis of each intersection the system is installed, and shall include all labor, equipment and materials necessary to complete-in-place. The video detection system shall be paid for under the "intersection detection system (camera)" pay item.

Subsection 614.14 shall include the following:

Pay Item	Pay Unit
Intersection Detection System (Camera)	Each

END REVISION OF SECTION 614

REVISION OF SECTION 614 – FLASHING BEACON

Section 614 of the Standard Specification is hereby revised for this project as follows:

Subsection 614.08 (f) shall include the following:

SCHOOL FLASHING BEACON ASSEMBLY

A school flashing beacon assembly shall be either solar or 120V as shown in the County standard details and as specified in the plans.

LED indications shall be furnished for all indications. For 120VAC installations, LED indications shall be warranted for a minimum of seven years by the manufacturer, shall be Gelcore series DR6 (RX11), or approved equal for 12" indications, and shall be Gelcore, Series DR4, or approved equal for 8" back mounted indications. For solar installations, LED indications shall be warranted for a minimum of five years by the manufacturer and LED indications shall be Leotek 12V, or approved equal.

Front mount school flashing beacon assembly signal heads shall flash alternately.

Each school flasher beacon assembly shall include a NEMA Type 4 enclosure for housing the associated time clock unit and electrical connections. When solar power is used in conjunction with the school flashing beacon assembly, the NEMA Type 4 enclosure shall be of sufficient size to house all associated solar power equipment, including the battery(s).

The NEMA Type 4 enclosure shall be lockable and provided with a treasury type lock Corbin number R357SGS, or exact equivalent

A time clock, RTC model number AP21T, or approved equal shall be incorporated in the school flashing beacon assembly NEMA Type 4 enclosure.

Terminal blocks shall be molded, phenolic, barrier type rated at 15 ampere, 1000 V. No wiring splices will be permitted within the school flasher beacon assembly or NEMA Type 4 enclosure without the permission of the Engineer.

Signs shall be provided by the County and shall be installed by the Contractor as an integral part of the flashing assembly.

For 120VAC installations, a main circuit breaker shall be installed in the NEMA Type 4 enclosure between the service feed and school flashing beacon assembly electronics. Fuse(s) in place of the circuit breaker shall not be permitted. A main circuit breaker shall not be required for solar type installations.

For 120VAC installations, a 120VAC receptacle shall be installed within the NEMA Type 4 enclosure.

WARNING OR REGULATORY SIGN FLASHING BEACON ASSEMBLY

A warning or regulatory sign flashing beacon assembly shall either solar or 120V as shown in the County standard details and as specified in the plans.

LED indications shall be furnished for all indications. For 120VAC installations, LED indications shall be warranted for a minimum of seven years by the manufacturer and LED indications shall be Gelcore, Series DR6 (RX11), or approved equal. For solar installations, LED indications shall be warranted for a minimum of five years by the manufacturer and LED indications shall be Leotek 12V, or approved equal.

-2-
**REVISION OF SECTION 614 –
FLASHING BEACON**

Front mount warning or regulatory sign flashing beacon assembly signal heads shall flash simultaneously.

All terminations shall be made on a terminal block located within the signal head. Terminal blocks shall be molded, phenolic, barrier type rated at 15 ampere, 1000 V. No wiring splices will be permitted within the warning or regulatory sign flashing beacon assembly without the permission of the Engineer.

Signs shall be provided by the County and shall be installed by the Contractor as an integral part of the flashing assembly.

Subsection 614.13 shall include the following:

School flashing beacon assemblies shall be paid for on a unit price basis and shall include all labor, equipment, materials, and electrical service connections necessary to install a school flashing beacon assembly, complete-in-place, on a single pole. School flashing beacon assemblies shall be paid for under the “school flashing beacon assembly” pay item.

Warning or regulatory sign flashing beacon assemblies shall be paid for on a unit price basis and shall include all labor, equipment, materials, and electrical service connections necessary to install a warning or regulatory sign flashing beacon assembly, complete-in-place, on a single pole. Warning or regulatory sign flashing beacon assemblies shall be paid for under the “warning/regulatory sign flashing beacon assembly” pay item.

Subsection 614.14 shall include the following:

Pay Item	Pay Unit
Warning/Regulatory Sign Flashing Beacon Assembly	Each
School Flashing Beacon Assembly	Each

END REVISION OF SECTION 614

**REVISION OF SECTION 614 -
UNINTERRUPTED POWER SUPPLY**

Section 614 of the Standard Specifications is hereby revised for this project as follows:

Subsection 614.08 (b) shall include the following:

An Uninterrupted Power Supply (UPS) shall only be installed where specified in the plans and may be considered by the Engineer on a per project basis. When specified in the project plans, a UPS shall be of the manufacturer and model number specified.

The UPS shall be installed per manufacturer's specifications.

Programming software and manuals shall be supplied with each UPS and shall become the property of the County at the completion of the project.

A UPS shall include all labor, equipment, and materials necessary to install the item complete-in-place.

Subsection 614.13 shall include the following:

UPS shall be measured by the units installed and shall include all labor, equipment, and materials necessary to install a UPS, complete-in-place. UPS shall be paid for under the pay item "Uninterrupted Power Supply".

Subsection 614.14 shall include the following:

Pay Item	Pay Unit
Uninterrupted Power Supply	Each

END REVISION OF SECTION 614

**REVISION OF SECTION 614 -
INTERCONNECT WIRE**

Section 614 of the Standard Specifications is hereby revised for this project as follows.

Subsection 614.06, shall contain the following:

HARDWIRE/COPPER INTERCONNECT

Where Hardwire/Copper telemetry cable is required, telemetry cable shall be solid conductor wire, 22 gauge, with a minimum of six (6) pairs. Telemetry cable shall be rated appropriately for the type of installation.

Subsection 614.13 shall include the following:

Hardwire/copper interconnect shall be measured by the linear feet installed and shall include all labor, equipment and materials necessary to install the item complete-in-place. Hardwire/copper interconnect shall be paid for under the pay item "interconnect wire".

Subsection 614.14 shall include the following:

Payment will be made under:

Pay Item

Interconnect Wire

Pay Unit

Linear Feet

END REVISION OF SECTION 614

REVISION OF SECTION 614 - FIBER OPTIC CABLE - GENERAL

Section 614 of the Standard Specifications is hereby revised for this project as follows:

Subsection 614.01 shall include the following:

This work provides for the installation of fiber optic communications cable to be installed in conduit or duct as specified in the plans. All fiber cable shall be of Non-Armored, All-Dielectric, Single Jacketed, Loose Tube Gel-Filled or Loose Tube Dry Block Construction for outside plant installation. All labor and materials required to fan-out, terminate, splice or otherwise connect fiber optic cables at individual controller cabinets, will be paid separately under the Telemetry (Field) pay item. The contractor shall be required to demonstrate successful signal system communications to the Engineer as a requirement of acceptance of this item.

Subsection 614.10 shall include the following:

All fiber-optic interconnect cable shall be furnished by the Contractor, and installed, spliced (if required and only as approved by the Engineer), terminated, connected and tested by the Contractor.

A 14 AWG locate wire shall be installed for the complete length of all new conduit runs containing fiber optic cable. Where joint trenching is used, only one locate wire need be installed for each joint trench. Cable installations with a length greater than 400' between pull boxes shall be equipped with a pull tape. The pull tape shall have a minimum tensile strength of 1250 lbs. and be of a design and manufacture that prevents cutting or burning into the conduit during cable installation.

Cable ends shall be stored in pull boxes or splice closures at locations indicated in the plans or as directed by the Engineer. Fibers to be spliced and/or connected in any manner shall be limited to those identified in the plans, and only in designated controller cabinets or splice closures. All other fibers shall be left uncut or sealed as appropriate in a manner recommended by the cable manufacturer.

Fiber optic cable shall be installed in a continuous run between all controller cabinets and splice closures as shown in the plans. Lateral cables shall be spliced only in splice closures and routed to the controllers as shown in the plans. **Under no conditions shall the fiber cable be cut out or spliced at intermediate points without the express written direction of the Engineer.**

Cable shall be installed in new conduit or existing conduit as specified in the plans. The Contractor shall be required to leave a minimum of 10 feet of cable slack in the equipment controller cabinet. The Contractor shall leave a minimum of 50 feet of cable slack in the pull box adjacent to the controller and shall leave a minimum of 50 feet of slack in all other communication pull boxes.

Cable Tags and Labels

Fiber optic cable shall be neatly coiled and clearly tagged and labeled at each communication pull box and at all locations where the fiber is exposed. Cable tags and Labels shall be as follows:

Materials: Metal or heavy plastic identification tags with cable type and number, copper pair or optic number assignments, and destination shall be provided on both ends of all cables (except station cables) and all splice cases. All cables shall be clearly labeled with cable number (County to determine) and size at each end of the cable, when it enters or leaves a conduit and at 30-foot intervals when run in accessible areas such as tunnels, manholes, ceilings, etc.

-2-
**REVISION OF SECTION 614
FIBER OPTIC CABLE - GENERAL**

Manufacturer: Tags shall be 3M, Panduit or an approved equivalent.

Controller cabinets to be connected under this project will connect directly to the appropriate controller as shown in the plans. This connection will be paid under Telemetry (Field).

General Requirements: The Contractor shall provide the Engineer with two copies of the cable manufacturer's cable specifications and installation instructions for fiber optic cable in conduit. All installation shall be in accordance with these practices except as otherwise directed by the Engineer.

Additional cable costs due to damage caused by the Contractor's neglect of recommended procedures shall be Contractor's responsibility. The main cable shall be installed in continuous runs except where cable type changes or where maximum pull lengths govern. The manufacturer's recommended limits for cable pull tensions shall not be exceeded. Cable ends shall be stored in controller cabinets or pull boxes immediately adjacent to cabinets or as directed by the City.

Lateral and Branch cables shall be installed using appropriate strain relief in the cabinet (through cable ties) at a minimum of three locations.

All fiber optic cables to be installed shall be checked with an OTDR before and after installation. Documentation of fiber performance shall be provided to the City within 30 days of test. All optical fibers shall be within the manufacturer's recommended tolerances. In addition, any other acceptance testing recommended by the manufacturer shall be provided. Data shall be supplied to the City prior to completion of the project.

Fiber optic cable shall be transported to site using cable reel trailers. Care shall be taken at all times to avoid scraping, denting, twisting, or otherwise damaging the cable before, during and after installation. Damaged cable shall be replaced by the Contractor without additional compensation.

Cable shall be installed in conduit or duct in the field in accordance with the contract drawings. The conduit and duct ends shall have all rough edges smoothed to prevent scraping the cable. All existing or suspected dirt and debris within the conduit shall be cleaned with compressed air before installing cable. A manufacturer recommended lubricant shall be applied to the cable to reduce friction between the cable and duct or conduit. Where fiber optic cables are to be installed in inner duct, the Contractor shall secure each section of the conduit to prevent it from being pulled without the cables.

A cable grip shall be attached to the cables so that no direct force is applied to the optical fiber. The cable grip shall have a ball-bearing swivel to prevent the cable from twisting during pulling. Cable rollers and feeders and winch cable blocks shall be used to guide the cable freely into the duct and at maintenance hole locations. Mechanical aids and pulling cable or ropes shall be used as required. **The maximum pulling tension as defined by the cable manufacturer shall not be exceeded.** The cable shall be taken up at intermediate pulling points with an intermediate cable take-up device as approved by the Engineer to prevent over-tension on the cable. Cable pulls shall be continuous and steady between pull points and shall not be interrupted until the entire run of cable has been pulled. Personnel equipped with two-way radios shall be stationed at each maintenance hole, cabinet, pedestal, communications box, and junction box through which the cable is to be pulled to observe and lubricate the cable. Intermediate splices between pull boxes shall not be allowed. The cable shall be securely fastened in place within pull boxes, pedestals, manholes and cabinets.

The contractor shall ensure cable length is sufficient to allow for connection between the

**REVISION OF SECTION 614
FIBER OPTIC CABLE - GENERAL**

communications equipment and the splice equipment and the splice enclosures including provision for slack, vertical runs, cable necessary for splicing, wastage and cable to allow for the removal of the splice enclosure for future splicing.

Lateral and Branch Fiber Optic Cable: Lateral/Branch fiber optic cable shall be installed in new or existing conduit, or along existing span wire, as depicted in the plans. Cables shall be provided with appropriate strain relief in the cabinet, consisting of cable ties in at least three interior cabinet locations. Lateral and Branch fiber optic cable shall be clearly tagged and labeled as such at pull boxes and all other locations where it is exposed. At any location where the cable is brought into or out of a span wire pole, the Contractor shall install a new weather-head to accommodate the bending radius of the cable.

Subsection 614.13 shall include the following:

Fiber Optic Cable will be measured by the linear feet for the main (backbone), lateral and branch cables, and shall include all labor and materials required to install the main, lateral, branch, and start cables through conduits to all pull boxes, cabinets and closures specified in the plans. Installation of all internal field cabinet telemetry, splicing, fan-out and termination of the cable at individual controller cabinets is paid for separately under the "Telemetry (Field)" pay item.

Subsection 614.14 shall include the following:

Payment will be made under:

Pay Item	Pay Unit
Fiber Optic Cable (Special)	Linear Feet

END OF REVISION OF SECTION 614

REVISION OF SECTION 614 - LOOSE TUBE FIBER OPTIC CABLE

Section 614 of the Standard Specifications is hereby revised for this project as follows.

Subsection 614.01 shall include the following:

When called for in the project plans or special provisions, fiber optic cable shall be installed of the fiber type, count, and configuration specified. Unless otherwise directed, all fiber shall be Single Mode type and shall conform to these specifications.

Fiber optic cable shall comply with industry standards such as Telcordia Technologies GR-20 (formerly Bellcore), Electronic Industries Association (EIA), Telecommunications Industry Association (TIA), International Telecommunications Union (ITU), International Electrotechnical Commission (IEC), and American Society for Testing and Materials (ASTM).

Fiber optic cable shall meet all requirements stated in this specification. The cable shall be an accepted product of the United States Department of Agriculture Rural Electrification Administration (REA) as meeting requirements of 7CFR1755.900.

The cable shall be new, unused, and of current design and manufacture.

All fiber cable shall be of Non-Armored, All-Dielectric, Single Jacketed, Loose Tube Gel-Filled or Loose Tube Dry Block Construction for outside plant installation.

When fiber cable installation includes cable transition into a building, and where the termination point is greater than 50' from the building's fiber cable entry point, fiber cable shall be converted to the appropriate cable type for the structure. Conversion shall be made via a fiber splice panel to minimize losses.

All fibers in the cable must be usable fibers and meet these specifications.

All optical fibers shall be sufficiently free of surface imperfections and inclusions to meet the optical, mechanical and environmental requirements of this specification.

Each optical fiber shall consist of a germania-doped silica core surrounded by a concentric glass cladding. The fiber shall be a matched clad design.

Each optical fiber shall be proof tested by the fiber manufacturer at a minimum of 100 kpsi (0.7 GN/m²).

The fiber shall be coated with a dual layer acrylate protective coating. The protective coating shall be in physical contact with the cladding surface.

The attenuation specification shall be a maximum value for each cabled fiber at 23 ± 5 degrees C on the original shipping reel.

COLOR CODE

The individual colors for fibers and buffer tube cable cores shall comply with EIA/TIA-598.

-2-
**REVISION OF SECTION 614 -
LOOSE TUBE FIBER OPTIC CABLE**

CENTRAL STRENGTH MEMBER

The central strength member functions as an anti-buckling element, and shall be a glass/epoxy composite dielectric rod. A polyethylene overcoat may be applied to the central member to provide the proper spacing between buffer tubes during stranding.

CABLE BUFFER TUBES

Optical fibers are enclosed within buffer tubes that have a diameter several times larger than the diameter of the fibers. The optical fibers are loose within the buffer tubes allowing the fibers to move freely. The loose buffer tubes should have a 2.5 mm diameter, with a nominal wall thickness of 0.4 mm.

For composite cable design, in which both multi-mode and single mode fiber occupy the same cable, all of the Single Mode fibers will be contained in the first buffer tubes. The Multi-mode fibers will be contained in subsequent buffer tubes.

Buffer tubes shall be of a dual-layer construction with the inner layer made of polycarbonate and the outer layer made of polyester.

Each buffer tube shall contain 12 fibers.

Filler rods may be included in the cable core to lend symmetry to the cable cross-section where needed.

The buffer tubes (and filler rods, if necessary) shall be stranded in a reverse oscillation lay (ROL) technique around the central strength member to allow for easy mid-span access. The core of buffer tubes shall be wrapped with two counter helically applied threads to bind together the cable core.

Binders shall be applied with sufficient tension to secure the buffer tubes to the central member without crushing the buffer tubes. The binders shall be non-hygroscopic, non-wicking (or rendered so by the flooding compound), and dielectric with low shrinkage.

Tensile strength shall be provided by high tensile strength aramid yarns, fiberglass yarns, or both.

Water blocking of the core outside, and around the buffer tubes, shall be accomplished via gel or dry block elements. In addition, water-blocking inside the buffer tubes shall be accomplished via gel or dry block elements.

In buffer tubes containing multiple fibers, the colors or numbers shall be stable during temperature cycling and not subject to fading or smearing onto each other or into the gel filling material. Colors shall not cause fibers to stick together.

For ease of jacket removal, one clearly identifiable polyester ripcord shall be provided directly under the cable sheath.

CABLE OUTER JACKET CHARACTERISTICS

All-Dielectric cables shall be sheathed with minimum or heavy density polyethylene. The minimal nominal jacket thickness shall be 1.4 mm.

-3-
**REVISION OF SECTION 614 -
LOOSE TUBE FIBER OPTIC CABLE**

Jacketing material shall be applied directly over the tensile strength members and water block flooding compound. The polyethylene shall contain carbon black to provide ultraviolet light protection and shall not promote the growth of fungus.

The cable sheath shall be free of holes, splits, and blisters.

CABLE OUTER JACKET MARKINGS

For standard outer jackets, printed characters shall be indent printed with white characters for black jackets, and black characters for non-black jackets.

The characters shall be of proper height and space to produce good legibility. Character height of 2 mm should facilitate adequate readability. An occasional illegible marking is permitted if there is a legible marking on either side.

The cable shall be sequentially marked at two feet intervals. The length intervals shall not be reset to zero on any length of the cable. The actual length of the cable shall be within -0/+1% of the length markings.

Each length of the cable shall be marked with manufacturer's name, manufacturer's part number, month and year cable was manufactured (MM-YY), telephone symbol (indicating fiber is of communications grade), fiber counts, fiber type (SM, MM, SM/MM), and manufacturer's serial number.

CABLE PACKAGING

The manufacturer shall supply the product using their standard reel sizes, methods, apparatus, and reel wood lagging.

Reels are assumed to be in good working condition, firm, and able to support the product through shipping and final installation. Reels shall be clean, dry, and free of excessive dirt. All reels shall be checked for high nails, stave fit, and proper stenciling.

Each wood reel shall be permanently marked with the manufacturer's name, "OPTICAL CABLE", an arrow with the words "CABLE END" to indicate the position of the outer cable end, an arrow with the words "ROLL THIS WAY" to indicate direction reel should be rolled to prevent loosening, and reel number.

Outer layers of the reel shall be covered with a protective wrap to limit the solar heating of the cable.

Each end of the cable shall have end seals, either end caps or KELLEMS pulling grips, in order to prevent moisture ingress into the cable during shipping, storage, or installation.

The top end of the cable shall be securely fastened to the inside of the reel flange to prevent the cable from becoming loose in transit or during handling. The bottom end, "test tail", shall be approximately three meters in length and easily accessible. The end shall be protected within a cable slot and be securely fastened to the outside of the reel flange with wire ties or walkout straps.

**REVISION OF SECTION 614 -
LOOSE TUBE FIBER OPTIC CABLE**

Each cable shall have certified test data securely fastened to the reel in a waterproof wrapping. The certified test data shall include the following information:

- Cable Number
- Date
- Customer Name
- Ordered Length
- Customer Order Number
- Ship Length
- Customer Cable Code
- Customer Reel Number
- Customer Attenuation Specifications
- Number of Fibers
- Cable Construction
- Fiber Transmission Data
- Bandwidth Data (Multimode Fiber Only)
- Authorized Signature

Each cable shall have a reel tag securely fastened to the reel in a waterproof wrapping. The reel tag (Cut Length Data Sheet) shall include the following information:

- Cable Number
- Date
- Customer Name
- Ordered Length
- Customer Order Number
- Ship Length
- Customer Cable Code
- Customer Reel Number
- Customer Attenuation Specifications
- Number of Fibers
- Beginning and Ending Sequential Length Markings
- Gross Weight
- Net Weight
- Inspected By Signature

SINGLE MODE FIBER SPECIFICATIONS

The dispersion un-shifted Single Mode fiber utilized in the cable specified herein shall conform to the following specifications:

- a. Typical Core Diameter: 8.3 micrometer;
- b. Cladding Diameter: 125.0 ± 1.0 micrometer;
- c. Core-to-Cladding Offset: ≤ 0.6 micrometer;
- d. Cladding Non-Circularity: ≤ 1.0 %, defined as $[1 - (\text{minimum Cladding diameter} / \text{maximum Cladding diameter})] \times 100$
- e. Coating diameter: 245 ± 10 micrometer;
- f. Colored Fiber Diameter: nominal 250 micrometer;
- g. Attenuation Uniformity: No point discontinuity > 0.10 dB at either 1310 nm or 1550 nm;

**REVISION OF SECTION 614 -
LOOSE TUBE FIBER OPTIC CABLE**

- h. Attenuation at the Water Peak: The attenuation at 1383 ± 3 nm shall not exceed 2.1 dB/km;
- i. Cutoff Wavelength: The cabled fiber cutoff wavelength shall be < 1260 nm;
- j. Mode-field Diameter (Petermann II): 9.30 ± 0.50 nm at 1310 nm;
- k. Mode-field Diameter (Petermann II): 10.50 ± 1.00 micrometer at 1550 nm;
- l. Zero Dispersion Wavelength (ZDW): $1301.5 \text{ nm} \leq 1321.5 \text{ nm}$;
- m. Zero Dispersion Slope (ZDS): $ZDS \leq 0.092 \text{ ps} / (\text{km} \times \text{nm}^2)$;
- n. Fiber Polarization Mode Dispersion (PMD): $0.5 \text{ ps} / \sqrt{\text{km}}$;
- o. Fiber Curl: ≥ 4.0 m radius of curvature;
- p. Maximum Tensile Loads: Short-Term 2700 N (600 lbs);
- q. Maximum Tensile Loads: Long-Term 890 N (200 lbs);
- r. Shipping, Storage, and Operating Temperature Range of the Cable: -40 Degrees C to +70 Degrees C.

MULTI-MODE FIBER SPECIFICATIONS

- a. Typical Core Diameter: 62.5 ± 3 micrometer;
- b. Core Non-Circularity: $\leq 5\%$
- c. Cladding Diameter: 125.0 ± 2.0 micrometer;
- d. Core-to-Cladding Concentricity: ≤ 3.0 micrometer;
- e. Cladding Non-Circularity: $\leq 2\%$, defined as $[1 - (\text{minimum Cladding diameter} / \text{maximum Cladding diameter})] \times 100$
- f. Coating diameter: 245 ± 5 micrometer;
- g. Cable Fiber Attenuation: ≤ 3.5 dB/km at 850 nm;
- h. Cable Fiber Attenuation: ≤ 1.0 dB/km at 1300 nm;
- i. Point Discontinuity: ≤ 0.2 dB at either 850 nm or 1300 nm;
- j. IEEE 802.3 GbE Distance: up to 500 m at 850 nm; up to 1000 m at 1300 nm;
- k. Maximum Tensile Loads: Short-Term 2700 N (600 lbs);
- l. Maximum Tensile Loads: Long-Term 890 N (200 lbs);
- m. Shipping, Storage, and Operating Temperature Range of the Cable: -40 Degrees C to +70 Degrees C.

GENERAL CABLE PERFORMANCE SPECIFICATIONS

The un-aged cable shall withstand water penetration when tested with a one meter static head or equivalent continuous pressure applied at one end of a one meter length of filled cable for 24 hours. No water shall *leak* through the open cable end. When a one meter static head or equivalent continuous pressure is applied at one end of a one meter length of aged cable for one hour, no water shall leak through the open cable end. Testing shall be done in accordance with FOTP-82, "Fluid Penetration Test for Filled Fiber Optic Cable".

When tested in accordance with FOTP-81, "Compound Flow (Drip) Test for Filled Fiber Optic Cable", Method A, the cable shall exhibit no flow (drip or leak) of filling or flooding compound at 80oC. If material flow is detected, the weight of any compound that drips from the sample shall be less than 0.05 grams (0.002 ounce).

The cable shall withstand a minimum compressive load of 220 N/cm (125 lbf/in) for non-armored cables applied uniformly over the length of the compression plate. The cable shall be tested in accordance with FOTP-41 "Compressive Loading Resistance of Fiber Optic Cables", except that the load shall be applied at the rate of 3 mm to 20 mm per minute and maintained for 10 minutes. The magnitude of the attenuation change shall be within the repeatability of the measurement system for 90% of the test fibers.

**REVISION OF SECTION 614 -
LOOSE TUBE FIBER OPTIC CABLE**

The remaining 10% of the fibers shall not experience an attenuation change greater than 0.1 dB at 1550 nm (single-mode). The average increase in attenuation for the fibers shall be ≤ 0.02 dB at 1300 nm (multimode). The repeatability of the measurement system is typically ± 0.05 dB or less. No fibers shall exhibit a measurable change in attenuation after load removal.

When tested in accordance with FOTP-104, "Fiber Optic Cable Cyclic Flexing Test", the cable shall withstand 25 mechanical flexing cycles at a rate of 30 ± 1 cycles per minute, with a sheave diameter not greater than 20 times the cable diameter. The magnitude of the attenuation change shall be within the repeatability of the measurement system for 90% of the test fibers. The remaining 10% of the fibers shall not experience an attenuation change greater than 0.1 dB at 1550 nm (single-mode). The repeatability of the measurement system is typically ± 0.05 dB or less. The cable jacket shall exhibit no cracking or splitting when observed under 5X magnification.

When tested in accordance with FOTP-25, "Repeated Impact Testing of Fiber Optic Cables and Cable Assemblies", the cable shall withstand 25 impact cycles. The magnitude of the attenuation change shall be within the repeatability of the measurement system for 90% of the test fibers. The remaining 10% of the fibers shall not experience an attenuation change greater than 0.1 dB at 1550 nm (single-mode). The repeatability of the measurement system is typically ± 0.05 dB or less. The average increase in attenuation for fibers shall be ≤ 0.04 dB at 1300 nm (multimode). The cable jacket shall not exhibit evidence of cracking or splitting at the completion of the test.

When tested in accordance with FOTP-33, "Fiber Optic Cable Tensile Loading and Bending Test", using maximum mandrel and sheave diameter of 560 mm, the cable shall withstand a tensile load of 2700 N (608 lbf) applied for one hour (using "Test Condition II" of the procedure). In addition, the cable sample, while subjected to a minimum load of 2660 N (600 lbf), shall be able to withstand a twist of 360 degrees in a length of less than 3 meters. The magnitude of the attenuation change shall be within the repeatability of the measurement system of 90% of the test fibers. The remaining 10% of the fibers shall not experience an attenuation change greater than 0.1 dB at 1550 nm. The repeatability of the measurement system is typically ± 0.05 dB or less. The average increase in attenuation for fibers shall be ≤ 0.40 dB at 1300 nm (multimode). The cable shall not experience a measurable increase in attenuation when subjected to the rated residual tensile load, 890 N (200 lbf).

When tested in accordance with FOTP-85, "Fiber Optic Cable Twist Test", a length of cable no greater than 2 meters will withstand 10 cycles of mechanical twisting. The magnitude of the attenuation change will be within the repeatability of the measurement system for 90% of the test fibers. The remaining 10% of the fibers will not experience an attenuation change greater than 0.1 dB at 1550 nm. The repeatability of the measurement system is typically ± 0.05 dB or less. The average increase in attenuation for fibers shall be ≤ 0.40 dB at 1300 nm (multimode). The cable jacket will exhibit no cracking or splitting when observed under 5X magnification after completion of the test.

When tested in accordance with the proposed FOP-181, "Lighting Damage Susceptibility Test for Fiber Optic Cables with Metallic Components", the cable shall withstand a simulated lighting strike with a peak value of the current pulse ≥ 105 kA. The test current used shall be damped oscillatory with a maximum time-to-peak value of 15 microseconds (which corresponds to a minimum frequency of 16.7 kHz) and a maximum frequency of 30 kHz. The time of half-value of the waveform envelope (t_2) shall be from 40 - 70 microseconds. In addition to the analysis criterion set forth in FOTP-181, the integrity of the buffer tubes (or analogous loose tube, i.e., core tube) and strength members must be intact after removal of the cable specimens from the test box.

-7-
**REVISION OF SECTION 614 -
LOOSE TUBE FIBER OPTIC CABLE**

QUALITY ASSURANCE PROVISIONS

All optical fibers shall be proof tested by the fiber manufacturer at a minimum load of 100 ksi.

All optical fibers shall be 100% attenuation tested. The attenuation of each fiber shall be provided with each cable reel.

Subsection 614.13 shall include the following:

All performance and material requirements outlined herein for loose tube fiber optic cable shall be paid for under the "Fiber Optic Cable (Special)" pay item.

END REVISION OF SECTION 614

REVISION OF SECTION 614 - TEST FIBER OPTIC CABLE

Section 614 of the Standard Specifications is hereby revised for this project as follows.

Subsection 614.06, shall contain the following:

REQUIREMENTS

When fiber optic cable is installed, the fiber optic cable test shall consist of the testing for both multi-mode and single mode fiber optic cable as installed. The testing procedures involve an OTDR test and an Optical Power Meter Test.

The standards for fiber optic cable testing include:

Test jumpers and patch cords must be of the same fiber core size and connector type as the cable system:

- a. Multi-mode fiber 62.5/125 μ m
- b. Single Mode fiber 8.3/125 μ m

The light source and OTDR must operate within the range of 850 \pm 30 nm or 1300 \pm 20 nm for multi-mode testing in accordance with ANSI/EIA/TIA-526-14.

The light source and OTDR must operate with the range of 1310 \pm 10 nm or 1550 \pm 20 nm for single mode testing in accordance with ANSI/EIA/TIA-526-7.

The power meter and the light source must be set to the same wavelength during testing.

The power meter must be calibrated and traceable to the National Institute of Standards and Technology (NIST).

All system connectors, adapters and jumpers must be cleaned as per manufacturer's instructions before measurements are taken.

MATERIALS

The following fiber optic test equipment is required to perform fiber optic cable tests:

- a. An OTDR;
- b. A test reel, of at least 900 feet;
- c. A light source at the appropriate wavelength;
- d. Optical Power Measurement Equipment;
- e. Test Jumpers as specified

**REVISION OF SECTION 614
TEST FIBER OPTIC CABLE**

Multi-mode Fiber Test Jumpers

- a. CPR Test Jumper-1 shall be 1-5 meters long with connectors compatible with the light source and power meter and have the same fiber construction as the link segment being tested.
- b. CPR Test Jumper-2 shall be 1-5 meters long with connectors compatible with the light source and power meter. Test Jumper-2 shall contain Class IV single mode fiber for tests on 1300 nm light sources and from which is single-moded at 850 micrometer for tests on 850 nm light sources.

Single Mode Fiber Test Jumpers

- a. CPR Test Jumper-1 and Test Jumper-2 shall be 1-5 meters long with connectors compatible with the light source and power meter and have the same fiber construction as the link segment being tested.

FIBER TESTING WITH OTDR

The Contractor shall perform an OTDR test of all fibers in all tubes on the reel, prior to installation of the fiber. The test results shall be supplied to the Engineer prior to installation of the cable.

If the fiber is specified as "Install Only", the Contractor shall test the fiber on the reel and provide the test results to the Engineer prior to accepting the cable. After installation, if there are unused portions of cable remaining on the reel, the Engineer may request the Contractor or other qualified technician to perform a reel test. The Contractor shall provide the Engineer the test results prior to delivering the cable to the Engineer. Any cable damaged while in the Contractor's possession shall be replaced at the Contractor's expense.

All fiber testing shall be performed on all fibers in the completed end-to-end system. Testing shall consist of a bi-directional end-to-end OTDR trace performed per TIA/EIA- 455-61. The system margin loss measurements shall be provided at 850 nm and 1300 nm for multi-mode fibers and 1310 nm and 1550 nm for single mode fibers.

Segmented end-to-end testing shall not be less than 1 kilometer (1 mile). Patches for testing shall not exceed five (5).

If the plans require installation of a fiber optic patch panel, the Contractor shall supply patch cords to patch all terminated fibers through the panel for all fiber testing. If patch cords are specified in the plans for final equipment installation, these patch cords shall be connected using a test coupling for the end-to-end test.

REVISION OF SECTION 614 TEST FIBER OPTIC CABLE

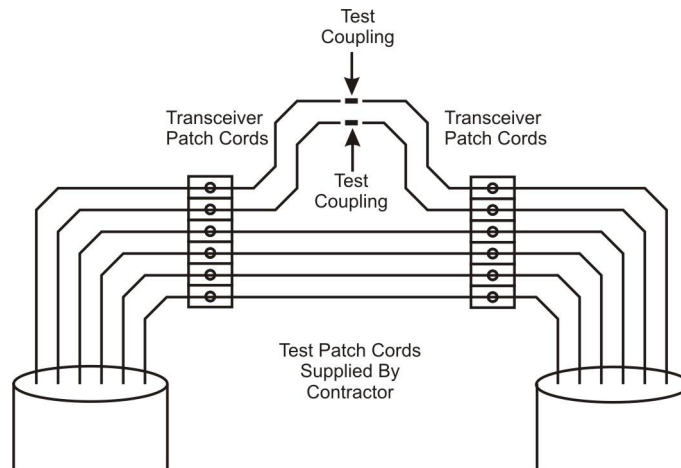

OTDR readings will be used to ensure proper installation and to troubleshoot faults. OTDR signature traces will be used for documentation and maintenance. An OTDR provides an indirect estimate of the loss of the cable plant; generally, more accurate or reliable values will be obtained by using an Optical Power Meter. For fibers that are identified in the plans to be left unterminated, an OTDR shall be used to test end-to-end attenuation.

Loss numbers for the installed link shall be calculated by taking the sum of the bi-directional measurements and dividing that sum by two.

The Contractor shall use an OTDR that is capable of storing traces electronically and shall save each final trace.

To ensure the traces identify the end points of the fiber under test and the fiber designation, the Contractor shall use a test reel, if required, to eliminate the “dead zone” at the start of the trace so that the start of the fiber under test can be identified on the trace. Indicate the length of the test reel for all test results.

If the fiber designation is not indicated on the trace itself, the Contractor shall provide a cross-reference table between the stored trace file name and the fiber designation.

In compliance with EIA/TIA-455-61 “Measurement of Fiber or Cable Attenuation Using an OTDR” the Contractor shall record the following information during the test procedure:

- a. Names of personnel conducting the test.
- b. Type of test equipment used (manufacturer, model, serial number, calibration date).
- c. Date test is being performed.
- d. Optical source wavelength and spectral width.
- e. Fiber identification.
- f. Start and end point locations.
- g. Launch conditions
- h. Method of calculation for the attenuation or attenuation coefficient.
- i. Acceptable link attenuation.

**REVISION OF SECTION 614
TEST FIBER OPTIC CABLE**

FIBER TESTING WITH OPTICAL POWER METER

The Contractor shall conduct an Optical Power Meter Test for each fiber installed.

Multi-mode segments shall be tested in one direction at both the 850 nm and the 1300 nm wavelengths.

Single mode segments shall be tested in one direction at both the 1310 nm and 1550 nm wavelengths.

In compliance with TIA/EIA-526-14A "Optical Power Loss Measurements of Installed Multi-mode Fiber Cable Plant" and TIA/EIA-526-7 "Measurement of Optical Power Loss of Installed Single Mode Fiber Cable Plant," the following information shall be recorded during the test procedure:

- a. Names of personnel conducting the test.
- b. Type of test equipment used (manufacturer, model, serial number, calibration date).
- c. Date test is being performed.
- d. Optical source wavelength, spectral width, and for multimode, the coupled power ratio (CPR).
- e. Fiber identification.
- f. Start and end point locations.
- g. Test direction.
- h. Reference power measurement (when not using a power meter with a Relative Power Measurement Mode).
- i. Measured attenuation of the link segment.
- j. Acceptable link attenuation.

The minor attenuation differences due to test direction are on par with the accuracy and repeatability of the test method. Lateral segments within a building are limited to 90 meters. Therefore, attenuation differences caused by wavelength are insignificant, and as a result, single wavelength testing is sufficient.

ACCEPTABLE ATTENUATION VALUES

Acceptable attenuation values shall be calculated for each fiber tested. These values represent the maximum acceptable test values.

A connection is defined as the joint made by mating two fibers terminated with re-mateable connectors (e.g. ST, SC, LC)

Multi-mode Fiber - The general attenuation equation for any multi-mode link is as follows:

- a. Acceptable Link Attenuation = Cable Attenuation + Connection Attenuation + Splice Attenuation + CPR Adjustment
- b. 62.5 nm multimode attenuation coefficients:
 - i. Cable Attenuation = Cable Length (km) x (0.34 dB/km@850 nm or 1.00 dB/km@1300 nm)

**REVISION OF SECTION 614
TEST FIBER OPTIC CABLE**

- ii. Connection Attenuation (ST or SC connectors) = (# of Connections x 0.39 dB) + 0.42 dB
- iii. Connection Attenuation (LC connectors) = (# of Connections x 0.14 dB) + 0.24 dB
- iv. Splice Attenuation (Mechanical or Fusion) = Splices x 0.30 dB
- v. CPR Adjustment = See table below.

MM Light Source CPR Adjustment					
	Cat. 1 Overfilled	Cat. 2	Cat. 3	Cat. 4	Cat. 5 Underfilled
Links with ST or SC Connections	+ 0.50	0.00	- 0.25	- 0.50	- 0.75
Links with SC Connections	+ 0.25	0.00	- 0.10	- 0.20	- 0.30

- c. The Coupled Power Ratio (CPR) of a light source is a measure of the modal power distribution launched into a multi-mode fiber. A light source that launches a higher percentage of its power into the higher order modes of a multi-mode fiber produces a more over-filled condition and is classified as a lower category than a light source that launches more of its power into just the lower order modes producing an under-filled condition. Under-filled conditions result in lower link attenuation, while over-filled conditions produce higher attenuation. Therefore, adjusting the acceptable link attenuation equation to compensate for a light source's launch characteristics increases the accuracy of the test procedure.

Single Mode Fiber - The general attenuation equation for any single mode link segment is as follows:

- a. Acceptable Link Attenuation = Cable Attenuation + Connection Attenuation + Splice Attenuation
- b. 8.3 nm single mode attenuation coefficients:
 - i. Cable Attenuation = Cable Length (km) x (0.34 dB/km@1310 nm or 0.25 dB/km@1550 nm)
 - ii. Connection Attenuation (ST or SC connectors) = (# of Connections x 0.39 dB). No more than 0.75 dB per connector.
 - iii. Splice Attenuation (Mechanical or Fusion) = Splices x 0.10 dB

TEST PROCEDURES

All fiber testing shall be performed on all fibers in the completed end-to-end system.

Multi-mode Fiber - The multi-mode fiber cable test shall be conducted as follows:

- a. Clean the test jumper connectors and the test coupling per manufacturer's instructions.
- b. Follow the test equipment manufacturer's initial adjustment instructions.
- c. Connect Test Jumper-1 between the light source and the power meter. Avoid placing bends in the jumper that are less than 100 mm (4 inches) in diameter.

-6-
REVISION OF SECTION 614
TEST FIBER OPTIC CABLE

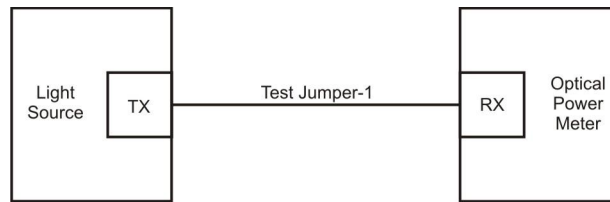

- d. If the power meter has a Relative Power Measurement Mode, select it. If it does not, reduce the Reference Power Measurement (P ref). If the meter can display power levels in dBm, select this unit of measurement to simplify subsequent calculations.
- e. Disconnect Test Jumper-1 from the power meter. Do NOT disconnect the test jumper from the light source.
- f. Connect Test Jumper-2 between the power meter and Test Jumper-1 using the test coupling. Test Jumper-2 should include a high order mode filter. This can be accomplished by wrapping the jumper three times around a 30 mm (1.2 inches) diameter mandrel.

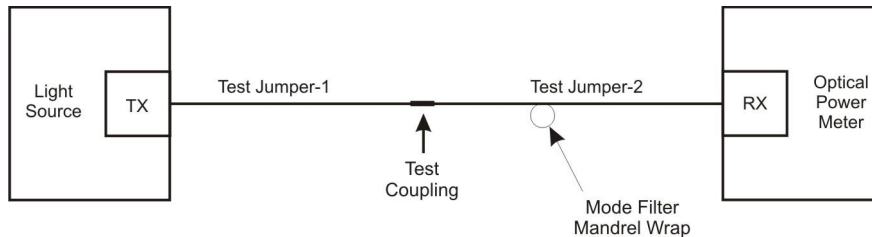

- g. Record the Power Measurement (P sum). If the power meter is in Relative Power Measurement Mode, the meter reading represents the CPR value. If the meter does not have a Relative Power Measurement Mode, perform the following calculation:
 - i. If P sum and P ref are in the same logarithmic units: $CPR (dB) = P_{sum} - P_{ref}$
 - ii. If P sum and P ref are in watts: $CPR (dB) = 10 \times \log_{10} [P_{sum}/P_{ref}]$

Single Mode Fiber - The single mode fiber cable test shall be conducted as follows:

- a. Clean the test jumper connectors and the test coupling per manufacturer's instructions.
- b. Follow the test equipment manufacturer's initial adjustment instructions.
- c. Connect Test Jumper-1 between the light source and the power meter. Avoid placing bends in the jumper that are less than 100 mm (4 inches) in diameter.

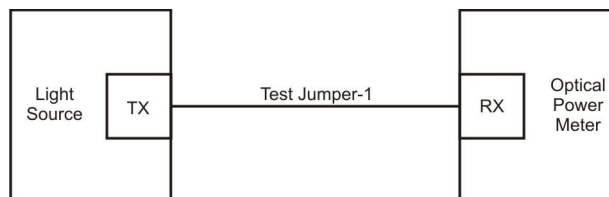

**REVISION OF SECTION 614
TEST FIBER OPTIC CABLE**

- d. If the power meter has a Relative Power Measurement Mode, select it. If it does not, reduce the Reference Power Measurement (P ref). If the meter can display power levels in dBm, select this unit of measurement to simplify subsequent calculations.
- e. Disconnect Test Jumper-1 from the power meter. Do NOT disconnect the test jumper from the light source.
- f. Attach Test Jumper-1 to one end of the cable plant to be measured and Test Jumper-2 to the other end.

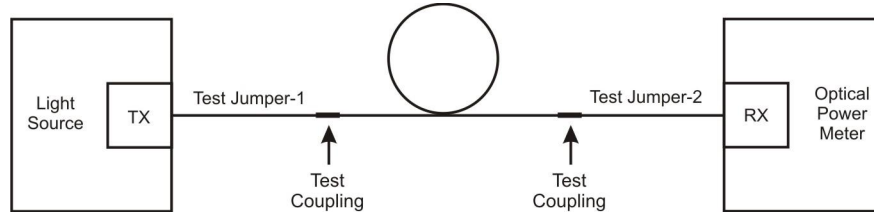

- g. Record the Power Measurement (P sum). If the power meter is in Relative Power Measurement Mode, the meter reading represents the true value. If the meter does not have a Relative Power Measurement Mode, perform the following calculation:
 - i. If P sum and P ref are in the same logarithmic units: $CPR (dB) = P_{sum} - P_{ref}$
 - ii. If P sum and P ref are in watts: $CPR (dB) = 10 \times \log_{10} [P_{sum}/P_{ref}]$

TEST ACCEPTANCE

The Contractor shall demonstrate and provide written certification that each Optical Power Test results in acceptable attenuation values.

The Contractor, solely at the Contractor's cost, shall remake any fusion splices that have test results exceeding acceptable attenuation values.

The Contractor, solely at the Contractor's cost, shall retest any fiber links that have been re-spliced.

The Contractor, solely at the Contractor's cost, shall bring any link not meeting the requirements of this specification into compliance.

SUBMITTALS

The Contractor shall submit test results documentation as both a hard copy and electronic copy.

After each reel test, the Contractor shall submit one hard copy of the OTDR trace for every fiber on the reel.

After installation, the Contractor shall submit one hard copy of the OTDR trace for every spliced fiber.

**REVISION OF SECTION 614
TEST FIBER OPTIC CABLE**

Hard copy traces shall be organized and bound in logical order in an 8 1/2" x 11" hard cover binder in addition to other documentation listed in the project Special Provisions package.

The Contractor shall submit, after approval of the hard copy traces, electronic copies of all traces and appropriate software to allow reading of the traces.

Subsection 614.13 shall include the following:

Fiber optic cable testing shall include all labor equipment, and materials necessary to complete end-to-end, bidirectional testing of all fiber installed as part of the project, complete-in-place.

Subsection 614.14 shall include the following:

No separate measurement or payment will be made for fiber optic cable testing. All cable (system) testing shall be considered incidental to the Fiber Optic Cable (Special) pay item.

END REVISION OF SECTION 614

REVISION OF SECTION 614 - TELEMETRY (FIELD)

Section 614 of the Standard Specifications is hereby revised for this project as follows.

Subsection 614.01 shall include the following:

This work consists of fan-out and termination of fiber optic (interconnect) cable at each controller cabinet location identified in the plans. It is also to include installation and connection of all necessary telemetry equipment including: ethernet switches, fiber optic transceivers, computer stations, patch panels, splice organizers, interface panels, optical splice closures, serial cables and pigtails. The Contractor shall be responsible for properly making all fiber optic cable connections to each modem within each controller cabinet, and as described in the plans.

ETHERNET MANAGED SWITCH

An Ethernet Managed Switch shall only be used where specified in the plans and project special provisions, and may be considered by the Engineer on a per project basis. When specified in the project plans and project specials, the Ethernet Managed Switch shall be of the manufacturer and model number specified.

An Ethernet Managed Switch shall include all labor, equipment, and materials necessary to install the item complete-in-place, including, but not limited to, power supplies, Ethernet cables, serial cables, and fiber patch cords.

Unless otherwise specified, the Contractor shall be responsible for proper programming, setup, and testing of the Ethernet Managed Switch. At the County's discretion, the County may opt to have their Maintenance Contractor or other third party complete Ethernet Managed Switch, setup, and/or testing. When the County's Maintenance Contractor or other third party is enlisted for programming, setup, and/or testing of the Ethernet Managed Switch, associated costs for the Maintenance Contractor or third party labor shall be the responsibility of the County.

FIBER OPTIC TRANSCEIVERS

Fiber Optic Transceivers shall only be used where specified in the plans and project specials, and may be considered by the Engineer on a per project basis. When specified in the project plans and project specials, Fiber Optic Transceivers shall be of the manufacturer and model number specified

Fiber Optic Transceivers shall include all labor, equipment, and materials necessary to install the item complete-in-place, including, but not limited to, fiber optic transceiver card racks, power supplies, serial cables, and fiber patch cords.

Unless otherwise specified, the Contractor shall be responsible for proper programming, setup, and testing of the Fiber Optic Transceivers. At the County's discretion, the County may opt to have their Maintenance Contractor or other third party complete Fiber Optic Transceivers programming, setup, and/or testing. When the County's Maintenance Contractor or other third party is enlisted for programming, setup, and/or testing of the Fiber Optic Transceivers, associated costs for the Maintenance Contractor or third party labor shall be the responsibility of County.

OPTICAL SPLICES AND OPTICAL SPLICE CLOSURES

Splices are not allowed without the authorization of the Engineer. If splices are authorized or specified on the plans, each such splice shall occur in a pull box of adequate size to house the splice closure and fiber optic cable slack without exceeding the fiber cable minimum bend radius. All splices shall be enclosed in a splice closure. Following successful splicing, said splice enclosure and fiber optic cable slack shall be placed inside the pull box.

-2-
**REVISION OF SECTION 614 -
TELEMETRY (FIELD)**

When fiber splicing is specified in the plans, splicing diagrams shall be provided by the County. Splicing diagrams shall define fiber cables to be spliced in part or whole and shall provide buffer tube designation, fiber designation, and routing information of each fiber to be spliced.

The Contractor shall accomplish the fiber splicing work using industry standard splicing tools and hardware.

Splice closures shall be used for splicing lateral fiber optic cable runs to the main fiber optic cable (backbone) at pull box locations that are identified in the plans. All closures shall include a 1-inch future port kit. The size of the splice closure at specific locations shall be governed by the number of cables and splices required.

BUFFER TUBE FAN-OUT

Fiber fan-outs shall be completed as defined in the plans and/or special provisions. Only those buffer tubes defined shall be fanned out. When additional buffer tubes are present, but are not to be fanned out, a termination panel shall be required. Buffer tubes which have not been fanned out shall be loosely coiled and secured within a termination panel.

Fiber fan-outs shall only be completed within a building or NEMA 4 rated cabinet and shall be of the count and type as defined in the plans and/or special provisions.

Industry standard fan-out kit tools and tool kit consumables shall be used.

During installation, and at no time, shall the fiber fan-out, in part or whole, be reduced to a length shorter than 36 inches. Fiber fan-outs shorter than 36 inches shall be replaced by the Contractor. Fees associated with replacement of fiber fan-outs which were installed by the Contractor, but which do not meet specifications, including terminations and testing, shall be borne by the Contractor and shall not be chargeable to the County.

TERMINATIONS

Only those fibers defined shall be terminated. All other fibers shall remain uncut.

Connectors shall be "ST" type unless otherwise specified. The connectors shall have a ceramic ferrule with nickel-plated nut and body. The connectors shall be compatible with a physical contact (PC) finish.

All connectors shall be polished to a PC finish such that the return loss per mated pair of connectors is less than -25 dB.

The return loss when the connector is mated with a previously installed connector shall be less than -18 dB.

The connector's insertion loss shall not be greater than 0.20 dB (typical). The connector's loss shall not vary more than 0.20 dB after 1000 repeated matings. Tensile strength shall withstand an axial load of 20 lbs with less than 0.20 dB change.

Index matching fluids or gels shall not be used. The connectors shall be compatible with the optical fiber surrounding jacket and shall be installed on one end of the optical fiber in accordance with the manufacturer's recommended materials, equipment, and practices. The connectors shall be suitable for the intended environment and shall meet, or exceed, the following environmental conditions.

-3-
**REVISION OF SECTION 614 -
TELEMETRY (FIELD)**

- Operating Temperature: -40 degrees C to +80 degrees C
- Storage Temperature: -40 degrees C to +85 degrees C

The connector loss shall not vary more than 0.20 dB over the operating temperature range. Connectors shall be protected by a suitably installed waterproof protective cap.

Subsection 614.13 shall include the following:

Telemetry (Field) shall be measured by the total number of terminals (i.e. cabinets and/or computer stations) at which the interconnect cable is fanned out, terminated, connected, patch panels and fiber-optic interfaces installed. All labor and materials required to perform panel installations, provide in-cabinet strain relief, fan-out, cable termination and connection to the controller is considered included in the unit price for this item. This item, therefore, includes the following:

1. All required in-cabinet cable ties and strain relief (including ancillary hardware and labor to complete);
2. All required fan-out kits, kit tools, ancillary hardware and labor to accomplish the fan-out at the cabinet;
3. All required pigtails and harness cables;
4. All required interconnect transceivers and switches, and fiber optic interface panels in individual controller cabinets as shown in the plans;
 - a. All required termination enclosures (including specified features), connectors, adapters, jumpers, pigtails, patch cord cables, ancillary hardware and labor required to accomplish the cabinet termination;
 - b. All required optical splice closures;
 - c. All other labor and material necessary to complete the item.

All labor, materials and testing necessary to complete this item to the satisfaction of the engineer shall be considered included in the unit price and will not be paid separately.

Subsection 614.14 shall include the following:

Payment will be made under:

Pay Item	Pay Unit
Telemetry (Field)	Each

END REVISION OF SECTION 614

**REVISION OF SECTION 614 -
SPREAD SPECTRUM RADIO**

Section 614 of the Standard Specifications is hereby revised for this project as follows:

Subsection 614.08 shall include the following:

Where specified in the plans, radio communications shall be included on the project. The radio communication system shall be compatible with the existing spread spectrum radio system and shall be of the manufacturer and model number specified.

Programming software and manuals shall be supplied with the radio system and shall become the property of the County at the completion of the project.

The radio communication system shall include all labor, equipment, and materials necessary to install the item complete-in-place, including, but not limited to, the antenna, coax cable, surge suppression, power supply, serial cable, and/or Ethernet cable.

At the direction of the Engineer, the Contractor shall place and align the antennae so that optimum performance from transmitter to receiver is achieved.

Unless otherwise specified, the Contractor shall be responsible for proper programming, setup, and testing of the radio communication system. At the County's discretion, the County may opt to have their Maintenance Contractor or other third party complete the radio communication system programming, setup, and/or testing. When the County's Maintenance Contractor or other third party is enlisted for programming, setup, and/or testing of the radio communication system, associated costs for the Maintenance Contractor or third party labor shall be the responsibility of the County.

Subsection 614.13 shall include the following:

The radio communication system shall be measured by the number of intersections the system is installed and shall include all labor, equipment, and materials necessary to install the item complete-in-place. The radio communication system shall be paid for under the pay item "Spread Spectrum Radio".

Subsection 614.14 shall include the following:

Payment will be made under:

Pay Item	Pay Unit
Spread Spectrum Radio	Each

END REVISION OF SECTION 614

**REVISION OF SECTION 625
CONSTRUCTION SURVEYING**

Section 625 of the Standard Specifications is hereby revised as follows:

Subsection 625.11 shall hereby include the following:

The Contractor shall submit construction surveying in the form of "as-built" drawings showing in detail all construction changes, including, but not limited to wiring, cable, and location and depth of conduit, and all other installations and equipment that varies from the plans. As-built plans shall be both electronic CAD revisions of the construction plans, and neatly and clearly drafted onto the plans in ink. As-Builts shall be submitted at the end of the project and shall be required prior to final acceptance by the County.

Subsection 625.12 and 625.13 shall hereby be replaced with the following:

Construction surveying shall not be paid for separately, but shall be included in the cost of the work performed.

END REVISION OF SECTION 625

**REVISION OF SECTION 630 -
CONSTRUCTION ZONE TRAFFIC CONTROL**

Section 630 of the Standard Specifications is hereby revised as follows:

Subsection 630.02 through 630.08 shall include the following:

Traffic control through the construction area is the responsibility of the Contractor. Before starting construction the Contractor shall submit, in writing, the proposed Method of Handling Traffic (MHT) for the initial phase of construction. When a different MHT is required for a subsequent construction phase, it must be submitted two weeks prior to starting that phase. All proposed MHTs shall be approved, in writing, by the Engineer. No phase of construction shall start until an acceptable MHT has been received and approved by the Engineer. The proposed methods shall include, as a minimum, the following:

A detailed diagram that shows the location of all sign placements, including advance construction signs (if not previously approved) and speed limit signs; method, length and time duration for lane closures; and location of flag persons.

A tabulation of all traffic control devices shown in the detailed diagram including, but not limited to: construction signs, vertical panel; vertical panel with light; Type 1 and Type 2 barricades; cones, drum channelizing devices; concrete barrier (temporary); advance warning flashing or sequencing arrow panel. Certain traffic control devices may be used for more than one operation or phase. However, all devices required for any particular phase must be detailed and tabulated for each phase. Certain traffic control devices may be used for more than one phase of construction.

- Number of flag-persons to be used.
- Number of days a Traffic Control Supervisor is to be required.
- Number of hours for uniformed traffic control.

Subsection 630.09 shall include the following:

Traffic Control. All proposed MHT's shall be approved, in writing, by the Engineer. No phase of construction shall start until an acceptable MHT has been received and approved by the Engineer.

Approval of the proposed MHT is intended to indicate those devices for which payment is to be made. Such approval does not relieve the Contractor of liability specifically assigned to him under the contract. The Contractor shall erect and maintain warning lights, signs, barricades, and sufficient safeguards around all excavations, embankments, and obstructions.

Subsection 630.15 shall be revised to include the following:

When the contract includes Traffic Control paid for as a Lump Sum:

Traffic Control devices will not be measured but will be paid for on a lump sum basis.

When the contract does not include pay items for Traffic Control:

Payment for all Traffic Control shall be included in the work.

END OF REVISION OF SECTION 630

TRAFFIC CONTROL PLAN – GENERAL

The key requirements of the Contractor's method of handling traffic (MHT) are outlined in Subsection 630.09.

The components of the TCP for this project are included in the following:

- (1) Subsection 104.04 and Section 630 of the CDOT *Standard Specifications for Road and Bridge Construction*
- (2) Current edition of the Colorado Department of Transportation, Standard Plans, Traffic Controls for Highway Construction, S-630-1, Sheets 1 through 12 as applicable.
- (3) Manual on Uniform Traffic Control Devices (MUTCD).

Traffic Control shall be provided as required by, in descending order of precedence, MUTCD, the plans and special provisions for this project, Colorado Department of Transportation Standard Specifications, and Colorado Department of Transportation M and/or S Standards.

Special Traffic Control Plan requirements for this project are as follows:

Steel drum channelizing devices shall not be used for traffic control.

During the construction of this project, traffic shall use the present traveled roadway at all times in each direction unless otherwise directed by the Engineer.

The Contractor shall not have construction equipment or materials in the lanes open to traffic any time, unless approved by the Engineer.

All personal / employee vehicle and construction equipment parking is prohibited when it conflicts with safety, access, or the flow of traffic.

The Contractor will be required to maintain access to all properties throughout the period of construction for this project. The Contractor shall be required to erect, maintain, and remove all barricades, traffic control signs and devices necessary for any street closure including detour signs. Any signs not in use shall be covered and turned away from traffic or removed from the job site. All traffic control devices shall be in good condition. Signs shall be clean, retro reflective, and **free of scratches and graffiti**. The contractor shall also notify local police and fire departments of work activity impacting traffic.

The Contractor shall install construction traffic control devices in locations where they do not block or impede other existing traffic control devices, or sidewalks for pedestrians, disabled persons, or bicyclists. When excavations remain open overnight as approved by the Engineer, they shall be properly marked to warn motorists and/or pedestrians. The excavation shall be properly barricaded for vehicles and/or pedestrians.

Excavations in streets or highways shall be performed in such a manner that, at a minimum, one (1) lane of traffic in each direction shall be open to public traffic during the approved work hours. Any street closure must be pre-approved by the Engineer. All such barricades and traffic control signs and devices shall be in accordance with the latest edition of the "Manual on Uniform Traffic Control Devices for Streets and Highways" including the "Colorado Supplement". The Contractor shall prepare and submit traffic control plans to the Engineer for review no later than forty-eight (48) hours in advance of any work.

When excavations remain open overnight as approved by the Engineer, they shall be properly marked to warn motorists and/or pedestrians. The excavation shall be properly barricaded for vehicles and/or pedestrians.

TRAFFIC CONTROL PLAN – GENERAL

The Contractor and subcontractors shall equip their construction vehicles with flashing amber lights. Flashing amber lights on vehicles and equipment shall be visible from all directions.

At the end of each day's work and any other time construction operations are suspended, all construction equipment and other obstructions shall be removed from that portion of the roadway open for use by public traffic. The Contractor shall maintain access to all roadways, side streets, walkways, alleyways, driveways, and hike/bike paths at all times unless otherwise approved by the Engineer. During non-construction periods (evenings, weekends, holidays, etc.), all work shall be adequately protected to insure the safety of vehicular and pedestrian traffic, as detailed in the Contractor's MHT. Excavations or holes shall be filled in or fenced when unattended.

The Contractor shall work only on week days between the hours of 8:30 AM and 4:00 PM, unless otherwise approved by the Engineer. The Contractor, upon approval of the traffic control plan by the Engineer, will be allowed lane closures in the public roadway weekdays only from the hours of 8:30 AM to 4:00 PM. The Contractor must receive written approval from the Engineer for lane closures at any other time; and also, for permission to work weekends or holidays. Lane closures within Colorado Department of Transportation right-of-way shall be consistent with the lane closure policy of the applicable Region of the Colorado Department of Transportation. The policy can be located at:

http://www.dot.state.co.us/Traffic_Manuals_Guidelines/Traffic_Guidelines_and_Information.asp

The Contractor shall be responsible for insuring that all work sites are properly cleaned and barricaded prior to the completion of the day's activities.

All construction vehicles shall remain on paved surfaces at all times.

Time required for changeover from existing signal equipment to new signal equipment shall be kept to a minimum. All new signal equipment shall be installed and tested prior to shut down of the existing signal equipment to the highest extent possible.

The Contractor shall coordinate all of the work on the roadway during any special event with the County.

Contractor shall coordinate with all tenants affected by alley and/or access two weeks prior to construction.

Contact Lorraine Taylor at RTD (303) 299-6440 regarding impacts to bus stop access (pedestrian or vehicular) 48 hours in advance of such impact.

All costs incidental to foregoing requirements shall be included in the original contract prices for the project and will not be measured and paid for separately.

UTILITIES

In order to complete the utility work with minimum delay to the project, the work described in these plans and specifications requires full cooperation between the Contractor and the utility owners.

PART 1 - CONTRACTOR SHALL PERFORM THE WORK LISTED BELOW:

Coordinate project construction with the performance by the utility owner of each utility work element listed in Part 2 below. Perform preparatory work specified in Part 2 for each utility work element. Provide an accurate construction schedule that includes all utility work elements to the owner of each impacted utility. Provide each utility owner with periodic updates to the schedule. Conduct necessary utility coordination meetings, and provide other necessary accommodations as directed by the Engineer. Notify each utility owner in writing, with a copy to the Engineer, prior to the time each utility work element is to be performed by the utility owner. Provide the notice the number of days specified in Part 2 immediately prior to the time the utility work must be begun to meet the project schedule.

Prior to excavating, the Contractor shall positively locate all potential conflicts with existing underground utilities and proposed construction, as determined by the Contractor according to proposed methods and schedule of construction. The Contractor shall modify construction plans to avoid existing underground facilities as needed, and as approved by the Engineer. Please note that UNCC marks only its members' facilities – Other facilities, such as ditches and drainage pipes may exist, and it is the Contractor's responsibility to investigate, locate and avoid such facilities.

It is the responsibility of the contractor to examine the site for evidence of failures of or deficiencies in existing utilities and to immediately call any such evidence of pre-existing damage to the attention of the County.

Without such evidence of pre-existing damage, the contractor hereby agrees that any and all damages (direct or indirect) to the utility owner, which may be subsequently discovered within those areas where construction occurred within six feet of the utility and within a period of three years from the date of construction, were caused by the construction activities. Furthermore, their repair is agreed to be the sole responsibility of the contractor.

The contractor hereby agrees that the repair of any and all damages (direct or indirect), that may be subsequently discovered and proven to have been caused by the construction activities, is the sole responsibility of the contractor.

It shall be the contractor's responsibility to protect all utilities within the area of construction. This includes all steps necessary to prevent subsidence of the soil adjacent to or near the utility. All utility locations and elevations will require field verification in cooperation with the affected companies and public agencies. The Contractor shall be responsible for locating all underground utilities, valve boxes, manholes, etc., and insuring that they are properly protected and adjusted as called for in the plans and/or project specials. When utility adjustments are required, but have not been called for in the plans and/or project specials, the Contractor shall notify the County.

The Contractor shall provide written notices to each utility owner, with a copy to the Engineer, immediately prior to each utility work element on the construction schedule that is expected to be coordinated with construction. The Contractor shall allow the number of work days required for each utility work element in the construction schedule. The number of days expected for construction and number of days of prior notice is specified below for each utility owner.

Provide traffic control, as directed by the Engineer, for any utility work by the utility owner expected to be coordinated with construction. However, traffic control for utility work outside of typical project work hours shall be the responsibility of the utility owner.

-2-
UTILITIES

Perform each utility work element for every utility owner affected by the project. The Contractor shall give notice of not less than forty-eight (48) hours to the Department of the County having charge of any property or utilities served by the County and to other owner or owners of public or private property or utilities when they will be affected by the work to be performed under the Contract; and shall make all necessary arrangements with such departments, owner or owners for the removal, replacement, or protection of such property or utilities.

All Utility Owners:

Contractor shall locate and pothole all potential conflicts with existing buried utility facilities with the proposed construction, as shown on the plans or by field location markings. If a conflict exists, modify proposed construction plans to avoid all existing buried utility facilities as approved by the Engineer.

Contractor shall contact utility owners 5 days prior to potholing to allow their observation of potholing activities.

PART 2 - UTILITY OWNERS SHALL PERFORM THE WORK LISTED BELOW:

Although the Contractor shall provide traffic control for utility work expected to be coordinated with construction, traffic control for utility work outside of typical project work hours shall be the responsibility of the utility owner. The utility owner shall prepare and submit to the County Engineer a Method of Handling Traffic for utility work to be performed outside typical project work hours. The utility owner shall obtain acceptance of the Method of Handling traffic from the County prior to beginning the utility work to be performed outside typical project work hours.

All Utility Owners:

Contractor shall locate and pothole all potential conflicts with existing buried utility facilities with the proposed construction, as shown on the plans or by field location markings. If a conflict exists, modify proposed construction plans to avoid all existing buried utility facilities as approved by the Engineer.

Contractor shall contact utility owners 5 days prior to potholing to allow their observation of potholing activities.

Street Lighting & Electric Distribution:

The Contractor shall notify the Engineer a minimum of three (3) weeks prior to the signal turn-on so that orders may be issued for power connection to the intersection on the specified turn-on date.

If necessary, the utility company shall relocate aerial facilities as required to attain minimum required separation from proposed traffic signals, luminaries, and vertical clearance, and to prevent obstruction of drivers' view of the proposed traffic signals. Contractor shall construct the proposed traffic signals after utility company has completed the relocating, raising or under grounding of the existing aerial distribution facilities. This work shall be coordinated with construction and completed within 120 calendar days of the date of signature of the utility company concurrence letter.

-3-
UTILITIES

The Contractor shall notify the Engineer a minimum of three (3) weeks prior to the signal turn-on so that orders may be issued for power connection to the intersection on the specified turn-on date.

After the Contractor has completed the construction of the proposed traffic signals and they are operational, the power company shall disconnect the power source to the existing traffic signal controller and luminaires. This work shall be coordinated with the construction and is expected to take one (1) working day per intersection to complete.

Contractor shall provide the utility owner written notice. This notice shall be submitted 60 days prior to each intersection utility work element and is to be coordinated with construction.

GENERAL:

The Contractor shall comply with Article 1.5 of Title 9, CRS ("Excavation Requirements") when excavating or grading is planned in the area of underground utility facilities. The Contractor shall notify all affected utilities at least three (3) business days, not including the actual day of notice, prior to commencing such operations. Contact the Utility Notification Center of Colorado (UNCC), use phone no. **1-800-922-1987**, to have locations of UNCC registered lines marked by member companies. All other underground facilities shall be located by contacting the respective company. Utility service laterals shall also be located prior to beginning excavation or grading.

The locations of utility facilities as shown on the plan sheets, and herein described, were obtained from the best available information.

All costs incidental to the foregoing requirements will not be paid for separately but shall be included in the work.