

Community & Economic  
Development Department

adcogov.org



4430 South Adams County Parkway  
1st Floor, Suite W2000B  
Brighton, CO 80601-8218

PHONE 720.523.6800

EMAIL [epermitcenter@adcogov.org](mailto:epermitcenter@adcogov.org)

## Request for Comments

Case Name: Wolf Creek Run West, Filling 2B Final Plat  
Case Number: PLT2024-00007

May 9, 2024

The Adams County Board of County Commissioners is requesting comments on the following application: **Major Subdivision Final Plat to create 78 lots on 54 acres within the Wolf Creek Run West PUD.** This request is located northwest of the intersection of East 26th Avenue and Piggott Road. The associated Assessor's Parcel Number is 0181329200008.

Please forward any written comments on this application to the Community and Economic Development Department at 4430 South Adams County Parkway, Suite W2000A Brighton, CO 80601-8216 or call (720) 523-6800 by June 4, 2024, in order that your comments may be taken into consideration in the review of this case. If you would like your comments included verbatim please send your response by way of e-mail to [GJBarnes@adcogov.org](mailto:GJBarnes@adcogov.org).

Once comments have been received and the staff report written, the staff report and notice of public hearing dates may be forwarded to you upon request. The full text of the proposed request and additional colored maps can be obtained by contacting this office or by accessing the Adams County web site at [www.adcogov.org/current-land-use-cases](http://www.adcogov.org/current-land-use-cases). Thank you for your review of this case.

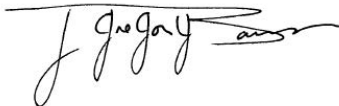

Greg Barnes  
Principal Planner

BOARD OF COUNTY COMMISSIONERS

Eva J. Henry  
DISTRICT 1

Charles "Chaz" Tedesco  
DISTRICT 2

Emma Pinter  
DISTRICT 3

Steve O'Dorisio  
DISTRICT 4

Lynn Baca  
DISTRICT 5



## DEVELOPMENT APPLICATION FORM

**PROJECT NAME:**

### APPLICANT

Name(s):  Phone #:   
Address:   
City, State, Zip:   
2nd Phone #:  Email:

---

### OWNER

Name(s):  Phone #:   
Address:   
City, State, Zip:   
2nd Phone #:  Email:

---

### TECHNICAL REPRESENTATIVE (Consultant, Engineer, Surveyor, Architect, etc.)

Name:  Phone #:   
Address:   
City, State, Zip:   
2nd Phone #:  Email:

---

**DESCRIPTION OF SITE**

Address:

City, State, Zip:

Area (acres or square feet):

Tax Assessor Parcel Number

Existing Zoning:

Existing Land Use:

Proposed Land Use:

Have you attended a Conceptual Review? YES  NO

If Yes, please list PRE#:

I hereby certify that I am making this application as owner of the above-described property or acting under the authority of the owner (attached authorization, if not owner). I am familiar with all pertinent requirements, procedures, and fees of the County. I understand that the Application Review Fee is non-refundable. All statements made on this form and additional application materials are true to the best of my knowledge and belief.

Name:

Date:

Owner's Printed Name

Name:

Owner's Signature



## Major Subdivision Final Plat Requirements

1. **Subdivision Name, Subtitle:** Name of subdivision at the top of the sheet, followed by a subtitle identifying the section, township and range information along with County and State.
2. **Property Description:** An accurate and clear property (legal) description of the overall boundary of the subdivision with the acreage of the subdivision. All courses in the property (legal) description shall be shown and labeled on the plat drawing, with all bearings having the same direction as called out in the legal description. The only exception being where more than one description is required, going a different direction over the same course. The direction shall then hold for the description having more weight (i.e., the overall boundary) for purposes of the plat. If both record and "as-measured" dimensions are being used, show both and clearly label on the plat drawing. Point of commencement and/or point of beginning shall be clearly labeled on the plat drawing.
3. **Ownership Certificate:**
  - a. Know all men by these presents that (owner name(s)), being the sole owner of the following described tract of land:
  - b. Legal Description
  - c. Have (Has) by these presents laid out, platted and subdivided the same into lots, streets and easements as shown on this plat under the name and style of (subdivision name).
4. **Dedication Statements:** Statements of land to be dedicated to the County for parks or other public uses, grants of easements and dedication of public streets to the Adams County are required.
  - a. All plats with public streets shall have the following sentence in the dedication statement: *All public streets are hereby dedicated to Adams County for public use.*
  - b. All plats with public easements and/or tracts must have the following sentence in the dedication statement: *The undersigned does hereby dedicate, grant and convey to Adams County those Public Easements (and tracts) as shown on the plat; and further restricts the use of all Public Easement to Adams County and/or its assigns, provided however, that the sole right and authority to release or quitclaim all or any such Public Easements shall remain exclusively vested in Adams County.*
  - c. All plats with private streets shall have the following sentence in the dedication statement: *All private streets (insert names) are privately owned and maintained by (list owner name, Owner's Association, etc.).*
  - d. All plats with other tracts being dedicated to the County shall have:



- i. A sentence in the dedication statement similar to "Tract X is hereby dedicated to Adams County for public use".
  - ii. A special numbered plat note defining the purpose and perpetual maintenance responsibility for the tract such as "Tract X is for public drainage, landscaping, trail and open space with maintenance of the surface being vested in the (District Name) Special Maintenance District".
5. **Surveyor's Statement:** Statement by a registered land surveyor, professionally licensed by the State of Colorado, to the effect that the layout represents a survey made by him and that the monuments thereon actually exist as located and that all dimensional and other details are correct.
6. **Access Provisions:**
  - a. **Statement Restricting Access:** A statement restricting access rights across the right-of-way lines of major highways, parkways, streets or freeways, where required as a provision of approval.
7. **Easement Statement:**
  - a. Six-foot (6') wide utility easements are hereby dedicated on private property adjacent to the front lot lines of each lot in the subdivision. In addition, eight-foot (8') wide dry utility easements are hereby dedicated around the perimeter of tracts, parcels and/or open space areas. These easements are dedicated to Adams County for the benefit of the applicable utility providers for the installation, maintenance, and replacement of utilities. Utility easements shall also be granted within any access easements and private streets in the subdivision. Permanent structures, improvements, objects, buildings, wells, water meters and other objects that may interfere with the utility facilities or use thereof (Interfering Objects) shall not be permitted within said utility easements and the utility providers, as grantees, may remove any Interfering Objects at no cost to such grantees, including, without limitation, vegetation.
8. **Storm Drainage Facilities Statement:**
  - a. The policy of the County requires that maintenance access shall be provided to all storm drainage facilities to assure continuous operational capability of the system. The property owners shall be responsible for the maintenance of all drainage facilities including inlets, pipes, culverts, channels, ditches, hydraulic structures, and detention basins located on their land unless modified by the subdivision development agreement. Should the owner fail to maintain said facilities, the County shall have the right to enter said land for the sole purpose of operations and maintenance. All such maintenance cost will be assessed to the property owners.



## 9. Layout:

- a. **Boundary Lines:** The subdivision boundary will be clearly distinguishable from other map lines by use of a distinct line type and/or thickness. All lines will be labeled with a complete bearing and distance, and all curves will be labeled with a central angle (delta), radius and arc length. Radial bearings and/or chord bearings will be provided for all nontangent curves. All dimensions to be determined by accurate field survey which must balance and close within limit of one in five thousand (5,000). Show adjacent and/or intersecting plat/deed lines and label appropriately to include recording information (book and page and/or reception number).
- b. **Streets:** All street rights of way defined by the plat will be clearly distinguishable from other map lines by use of a distinct line type and/or thickness. All lines will be labeled with a complete bearing and distance, and all curves will be labeled with a central angle (delta), radius and arc length. Radial bearings and/or chord bearings will be provided for all nontangent curves. Widths shall be labeled from each right-of-way line normal to the corresponding street center line. All street center lines defined by the plat will be clearly distinguishable from other map lines by use of distinct line type and/or thickness. All lines will be labeled with a complete bearing and distance and all curves will be labeled with a central angle (delta), radius and arc length. Radial bearings and/or chord bearings will be provided for all nontangent curves. The plat shall show the right-of-way lines, widths, locations and street names of all existing and proposed public or private streets:
  - i. Within the proposed subdivision, and
  - ii. Immediately abutting the proposed subdivision, and
  - iii. Any private street shall include the designation "(Private)" immediately following street name; any other private right of way that is not named shall include the designation "(Private)" in a manner that clearly conveys such a status.
- c. **Easements:** All easements as required by Adams County and other public and quasi-public agencies. Said easements shall be clearly labeled to include width, use and identification as public or private, if necessary. Tie to property lines and annotate with bearings and distances as necessary. Clearly show and label all existing easements, to include width and recording information, that cross, abut or are located within the subdivision boundary.
- d. **Lots and Blocks:** All lines of lots, blocks and other parcels of land defined by the plat will be clearly distinguishable from other map lines by use of a distinct line type and/or thickness. All lines will be labeled with a complete bearing and distance and all curves will be labeled with a radius and arc length. Lots must close to one in five thousand (5,000).
- e. **Readability:** All line annotation and all other text will be easily and clearly readable. No text shall overwrite other text or be overwritten by map lines.
- f. **Leader Lines:** Use leader lines whenever a dimension is not clearly and unmistakably associated with a given line, line segment or arc.



- g. **Multiple Sheets:** Whenever a plat drawing spans multiple sheets, clear and well labeled match lines and a key map shall be included on each sheet. Labels will be of the nature "See Sheet of ". Duplicate street names, widths, lot numbers, tract names, easement labeling or any such labeling when any feature is shown on multiple sheets.
  - h. **Identification System:** All lots and blocks in the subdivision shall be numbered, beginning with the numeral "1" and continuing consecutively throughout the tract, with no omissions or duplications. All tracts shall be likewise labeled beginning with the letter "A". Lots and tracts shall be labeled with the area of the lot or tract.
  - i. **Legend:** Provide a legend which designates all lines and symbols except where called out on plat drawing.
  - j. **Inundation Mark:** The plat shall clearly show the 100-year floodplain line. Reference the appropriate FEMA panel by which the location of this line has been determined.
10. **Easements:** Book and page and/or reception number for all existing and newly created easements.
11. **Adjacent Subdivision:** Names of adjacent platted areas along with the reception and/or plat book and page number shall be shown. If unplatted, so indicate. Existing street rights of way that intersect the subdivision boundary or are adjacent to said boundary lines shall be clearly labeled with the street name, right of way width and appropriate deed or plat recording information wherein the right of way is defined. Show and label all existing lots and blocks that are immediately adjacent to the subdivision boundary.
12. **Basis of Bearings:** A clearly defined basis of bearings shall be provided, both verbally and graphically. All monumentation defining said line shall be shown and labeled on the plat drawing. When said line is not common with the subdivision boundary, it shall be accurately tied to the boundary with bearings and distances.
13. **Monuments:** All monuments used to determine and/or describe a boundary (including basis of bearings, point of beginning and point of commencement) shall be shown and clearly labeled on the plat drawing. Monuments for corners defined by the plat, or otherwise found to be missing in the field, shall be placed and set in accord with the requirements of the State of Colorado.
14. **Not A Part Of Subdivision:** All areas enclosed within the subdivision boundary which do not constitute a part of the subdivision shall be labeled "Not a part of this subdivision". All lines pertaining to such areas shall be dashed.
15. **Square Footage:** The area in square feet of all lot and tracts sought to be platted.

Community & Economic  
Development Department  
[www.adcogov.org](http://www.adcogov.org)



4430 South Adams County Parkway  
1st Floor, Suite W2000  
Brighton, CO 80601-8204  
PHONE 720.523.6800  
FAX 720.523.6998

**16. Operation and Maintenance Manual reference:** Refer to the Operation and Maintenance Manual approved with this Subdivision for Additional Drainage Guidelines.

**17. All other information required by State law.**



PROJECT DESCRIPTION  
WOLF CREEK RUN WEST – FILING 2B  
TOWN OF STRASBURG, ADAMS COUNTY, COLORADO

The proposed development takes place in the south-southeast portion of a ±179.59-acre tract of land bounded by Wolf Creek Run West – Filing 2A to the east, E 26th Avenue to the south, Wolf Creek Road to the west, and open space to the north. The proposed site will consist of a single-family development with 179 homes, and a future 40 to be developed in the future as a part of Wolf Creek Run West – Filing 3. Filing 2A, the portion of Wolf Creek Run West that is directly to the east of Filing 2B consists of 108 homes. The development will consist of underground utilities, stormwater management facilities, public roadways, two park areas, as well as the development of the single-family homes.

# WOLF CREEK RUN WEST FILING NO. 2B

CASE NO.: *PLT2024-*

A REPLAT OF LOT 1, BLOCK 1 AND LOT 1, BLOCK 2, WOLF CREEK RUN WEST FILING NO. 2A,  
 LOCATED IN THE SOUTH HALF OF SECTION 29,  
 TOWNSHIP 3 SOUTH, RANGE 62 WEST OF THE SIXTH PRINCIPAL MERIDIAN,  
 COUNTY OF ADAMS, STATE OF COLORADO  
 SHEET 1 OF 8

## OWNERSHIP AND DEDICATION CERTIFICATE

KNOW ALL MEN BY THESE PRESENTS THAT EAST PEAK LAND DEVELOPMENT, LLC, A COLORADO LIMITED LIABILITY COMPANY, BEING THE SOLE OWNER OF THE FOLLOWING DESCRIBED TRACT OF LAND:

LOT 1, BLOCK 1 AND LOT 1, BLOCK 2, WOLF CREEK RUN WEST FILING NO. 2A AS RECORDED AT RECEPTION NO. \_\_\_\_\_

CONTAINING A CALCULATED AREA OF 2,352,120 SQUARE FEET OR 53.9972 ACRES, MORE OR LESS.

HAVE BY THESE PRESENTS LAID OUT, PLATTED AND SUBDIVIDED THE SAME INTO LOTS, TRACTS, STREETS AND EASEMENTS AS SHOWN ON THIS PLAT UNDER THE NAME AND STYLE OF WOLF CREEK RUN WEST FILING NO. 2B, AND ALL PUBLIC STREETS ARE HEREBY DEDICATED TO ADAMS COUNTY FOR PUBLIC USE.

THE UNDERSIGNED DOES ALSO HEREBY DEDICATE, GRANT AND CONVEY TO ADAMS COUNTY THOSE PUBLIC EASEMENTS AND AS SHOWN ON THE PLAT; AND FURTHER RESTRICTS THE USE OF ALL PUBLIC EASEMENTS TO ADAMS COUNTY AND/OR ITS ASSIGNS, PROVIDED HOWEVER, THAT THE SOLE RIGHT AND AUTHORITY TO RELEASE OR QUITCLAIM ALL OR ANY SUCH PUBLIC EASEMENTS SHALL REMAIN EXCLUSIVELY VESTED IN ADAMS COUNTY.

## ACKNOWLEDGEMENT

EXECUTED THIS \_\_\_\_\_ DAY OF \_\_\_\_\_ A.D., 202\_\_\_\_.

BY: EAST PEAK LAND DEVELOPMENT, LLC., A COLORADO LIMITED LIABILITY COMPANY

NAME \_\_\_\_\_ AS \_\_\_\_\_ TITLE \_\_\_\_\_

STATE OF COLORADO )  
 COUNTY OF \_\_\_\_\_ ) SS

THE FOREGOING CERTIFICATE WAS ACKNOWLEDGED BEFORE ME THIS \_\_\_\_\_ DAY OF \_\_\_\_\_, 202\_\_\_\_, BY \_\_\_\_\_ AS AUTHORIZED SIGNATORY

FOR EAST PEAK LAND DEVELOPMENT, LLC, A COLORADO LIMITED LIABILITY COMPANY.

WITNESS MY HAND AND OFFICIAL SEAL.

NOTARY PUBLIC \_\_\_\_\_

MY COMMISSION EXPIRES: \_\_\_\_\_

ADDRESS \_\_\_\_\_

## BOARD OF COUNTY COMMISSIONERS APPROVAL

APPROVED BY THE ADAMS COUNTY BOARD OF COUNTY COMMISSIONERS THIS \_\_\_\_\_ DAY OF \_\_\_\_\_, 202\_\_\_\_.

CHAIR \_\_\_\_\_

## ADAMS COUNTY ATTORNEY'S OFFICE

APPROVED BY THE ADAMS COUNTY ATTORNEY'S OFFICE THIS \_\_\_\_\_ DAY

OF \_\_\_\_\_, 202\_\_\_\_.

APPROVED AS TO FORM \_\_\_\_\_

## SHEET INDEX

SHEET 1: COVER SHEET, LEGAL DESCRIPTION, NOTES  
 SHEET 2: OVERALL BOUNDARY  
 SHEET 3-8: DETAIL SHEETS

| LAND SUMMARY CHART |             |            |            |
|--------------------|-------------|------------|------------|
| TYPE               | AREA (S.F.) | AREA (AC.) | % OF TOTAL |
| LOTS (180)         | 1843841     | 42.3288    | 78.39%     |
| TRACTS (17)        | 231164      | 5.3068     | 9.83%      |
| PUBLIC ROW         | 277115      | 6.3617     | 11.78%     |
| TOTAL              | 2352120     | 53.9972    | 100.00%    |

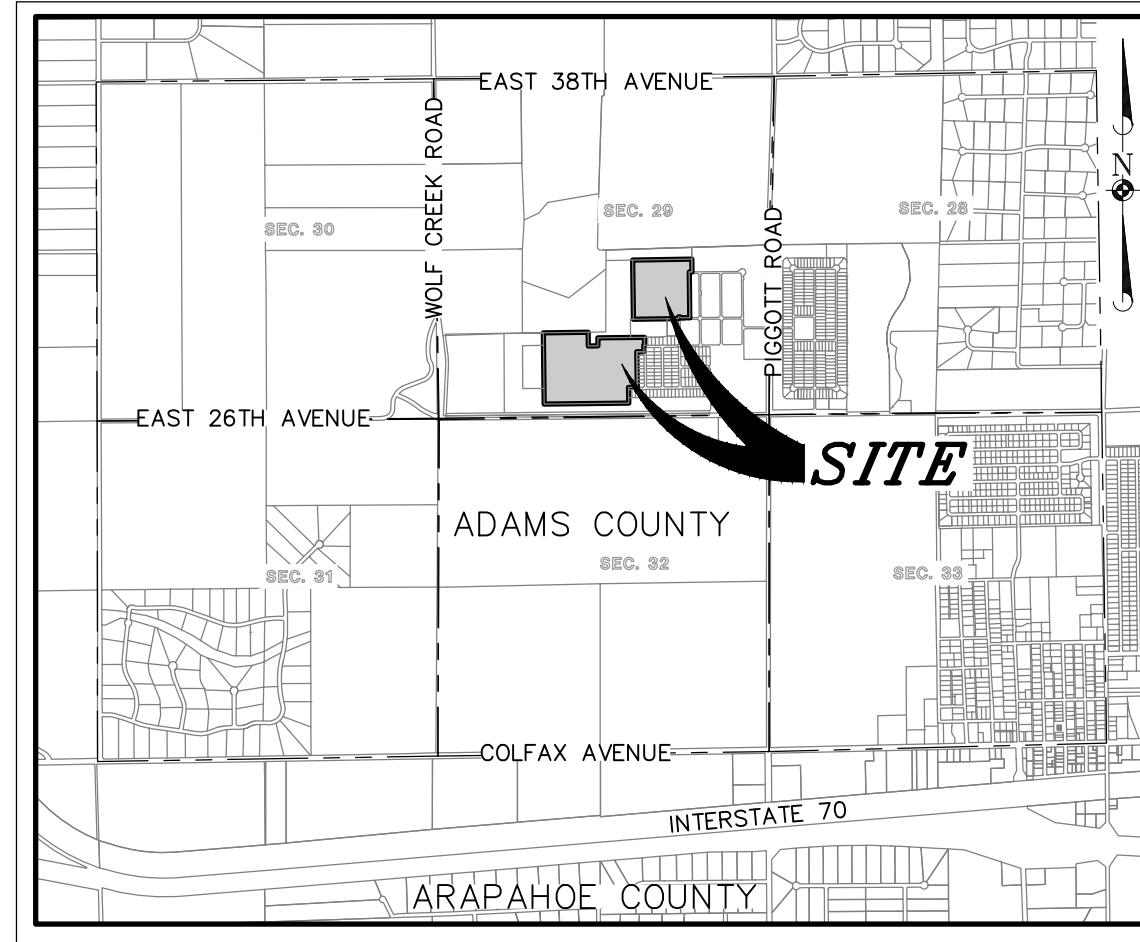

## VICINITY MAP

T3S, R63W OF THE 6TH P.M.  
 (1" = 3000')

## TRACT SUMMARY CHART

| TRACT   | AREA (S.F.) | AREA (AC.) | USE                                | OWNERSHIP                          | MAINTENANCE                        |
|---------|-------------|------------|------------------------------------|------------------------------------|------------------------------------|
| TRACT A | 59,408      | 1.3638     | OPEN SPACE, DRAINAGE AND UTILITIES | WOLF CREEK RUN WEST METRO DISTRICT | WOLF CREEK RUN WEST METRO DISTRICT |
| TRACT B | 22,189      | 0.5094     | OPEN SPACE, DRAINAGE AND UTILITIES | WOLF CREEK RUN WEST METRO DISTRICT | WOLF CREEK RUN WEST METRO DISTRICT |
| TRACT C | 6,623       | 0.1520     | VISITOR PARKING AND ACCESS         | WOLF CREEK RUN WEST METRO DISTRICT | WOLF CREEK RUN WEST METRO DISTRICT |
| TRACT D | 6,324       | 0.1452     | VISITOR PARKING AND ACCESS         | WOLF CREEK RUN WEST METRO DISTRICT | WOLF CREEK RUN WEST METRO DISTRICT |
| TRACT E | 9,840       | 0.2259     | VISITOR PARKING AND ACCESS         | WOLF CREEK RUN WEST METRO DISTRICT | WOLF CREEK RUN WEST METRO DISTRICT |
| TRACT F | 6,324       | 0.1452     | VISITOR PARKING AND ACCESS         | WOLF CREEK RUN WEST METRO DISTRICT | WOLF CREEK RUN WEST METRO DISTRICT |
| TRACT G | 6,643       | 0.1525     | VISITOR PARKING AND ACCESS         | WOLF CREEK RUN WEST METRO DISTRICT | WOLF CREEK RUN WEST METRO DISTRICT |
| TRACT H | 7,420       | 0.1704     | VISITOR PARKING AND ACCESS         | WOLF CREEK RUN WEST METRO DISTRICT | WOLF CREEK RUN WEST METRO DISTRICT |
| TRACT I | 6,375       | 0.1463     | VISITOR PARKING AND ACCESS         | WOLF CREEK RUN WEST METRO DISTRICT | WOLF CREEK RUN WEST METRO DISTRICT |
| TRACT J | 6,375       | 0.1463     | VISTOR PARKING AND ACCESS          | WOLF CREEK RUN WEST METRO DISTRICT | WOLF CREEK RUN WEST METRO DISTRICT |
| TRACT K | 5,146       | 0.1181     | VISITOR PARKING AND ACCESS         | WOLF CREEK RUN WEST METRO DISTRICT | WOLF CREEK RUN WEST METRO DISTRICT |
| TRACT L | 9,711       | 0.2229     | VISITOR PARKING AND ACCESS         | WOLF CREEK RUN WEST METRO DISTRICT | WOLF CREEK RUN WEST METRO DISTRICT |
| TRACT M | 9,711       | 0.2229     | VISITOR PARKING AND ACCESS         | WOLF CREEK RUN WEST METRO DISTRICT | WOLF CREEK RUN WEST METRO DISTRICT |
| TRACT N | 9,711       | 0.2229     | VISITOR PARKING AND ACCESS         | WOLF CREEK RUN WEST METRO DISTRICT | WOLF CREEK RUN WEST METRO DISTRICT |
| TRACT O | 5,610       | 0.1288     | VISTOR PARKING AND ACCESS          | WOLF CREEK RUN WEST METRO DISTRICT | WOLF CREEK RUN WEST METRO DISTRICT |
| TRACT P | 6,324       | 0.1452     | VISTOR PARKING AND ACCESS          | WOLF CREEK RUN WEST METRO DISTRICT | WOLF CREEK RUN WEST METRO DISTRICT |
| TRACT Q | 47,428      | 1.0888     | OPEN SPACE, DRAINAGE AND UTILITIES | WOLF CREEK RUN WEST METRO DISTRICT | WOLF CREEK RUN WEST METRO DISTRICT |

## NOTES

- NOTICE:** ACCORDING TO COLORADO LAW YOU MUST COMMENCE ANY LEGAL ACTION BASED UPON ANY DEFECT IN THIS SURVEY WITHIN THREE YEARS AFTER YOU FIRST DISCOVER SUCH DEFECT. IN NO EVENT MAY ANY ACTION BASED UPON ANY DEFECT IN THIS SURVEY BE COMMENCED MORE THAN TEN YEARS FROM THE DATE OF THE CERTIFICATION SHOWN HEREON.
- ANY PERSON WHO KNOWINGLY REMOVES, ALTERS OR DEFACES ANY PUBLIC LAND SURVEY MONUMENT OR LAND BOUNDARY MONUMENT OR ACCESSORY, COMMITS A CLASS TWO (2) MISDEMEANOR PURSUANT TO STATE STATUTE 18-4-508, C.R.S.
- THIS SURVEY DOES NOT CONSTITUTE A TITLE SEARCH BY MANHARD CONSULTING TO DETERMINE OWNERSHIP OR EASEMENTS OF RECORD. FOR ALL INFORMATION REGARDING EASEMENTS, RIGHTS-OF-WAY, AND TITLE OF RECORD, MANHARD CONSULTING RELIED UPON THE ALTA COMMITMENT PREPARED BY LAND TITLE GUARANTEE COMPANY, ORDER NO. ABC70779829-10, WITH AN EFFECTIVE DATE OF OCTOBER 30, 2023 AT 5:00 PM.
- THIS SURVEY WAS PREPARED FOR THE EXCLUSIVE USE OF THE PERSON(S) OR ENTITY(S) NAMED IN THE CERTIFICATE HEREON. SAID CERTIFICATE DOES NOT EXTEND TO ANY UNNAMED PERSON(S) OR ENTITY(S) WITHOUT AN EXPRESS RECERTIFICATION BY THE SURVEYOR NAMING SAID PERSON(S) OR ENTITY(S).
- THE LINEAL UNIT USED IN THE PREPARATION OF THIS PLAT IS THE U.S. SURVEY FOOT AS DEFINED BY THE UNITED STATES DEPARTMENT OF COMMERCE, NATIONAL INSTITUTE OF STANDARDS AND TECHNOLOGY.
- BASIS OF BEARINGS:** THE NORTH LINE OF THE SOUTHEAST QUARTER OF SECTION 29, TOWNSHIP 3 SOUTH, RANGE 62 WEST OF THE SIXTH PRINCIPAL MERIDIAN IS ASSUMED TO BEAR NORTH 89°03'28" EAST, BEING MONUMENTED ON THE WEST END BY A 3.25" ALUMINUM CAP STAMPED "PLS 25379" AND ON THE EAST END BY A 3.25" ILLEGIBLE ALUMINUM CAP.
- FLOODPLAIN:** A PORTION OF THE SURVEYED PROPERTY IS LOCATED WITHIN ZONE X, OTHER AREAS - DETERMINED TO BE OUTSIDE THE 0.2% ANNUAL CHANCE FLOODPLAIN, AND A PORTION OF THE SURVEYED PROPERTY IS LOCATED WITHIN ZONE AE. BASE FLOOD ELEVATIONS DETERMINED AS IDENTIFIED BY THE FEDERAL EMERGENCY MANAGEMENT AGENCY (FEMA) ON FLOOD INSURANCE RATE MAP (FIRM) - MAP NUMBER 08001C0740H WITH A MAP REVISED DATE OF MARCH 5, 2007.
- DRAINAGE AND UTILITY EASEMENTS LOCATED AS SHOWN HEREON ARE HEREBY GRANTED FOR THE INSTALLATION, MAINTENANCE, AND OPERATION OF THE UTILITIES AND DRAINAGE FACILITIES, INCLUDING BUT NOT LIMITED TO STREET LIGHTS, ELECTRIC LINES, GAS LINES, CABLE TELEVISION LINES, FIBER OPTIC LINES AND TELEPHONE LINES, AS WELL AS PERPETUAL RIGHT FOR INGRESS AND EGRESS FOR INSTALLATION, MAINTENANCE, AND REPLACEMENT OF SUCH LINES.
- SURFACED ACCESS ROADS CAPABLE OF WITHSTANDING THE IMPOSED LOADS OF FIRE APPARATUS AND ALL REQUIRED FIRE HYDRANTS SHALL BE INSTALLED AND MADE SERVICEABLE PRIOR TO AND DURING CONSTRUCTION.
- ALLEYS SHALL BE OWNED AND MAINTAINED BY THE WOLF CREEK RUN WEST HOA, FOR RESIDENTIAL ACCESS TO THE LOTS AND TRASH SERVICE.
- NO BUILDING PERMITS WILL BE ISSUED FOR ANY LOT UNTIL ALL PUBLIC IMPROVEMENTS, AS REQUIRED BY THE APPROVED CONSTRUCTION PLANS, HAVE BEEN COMPLETED AND ARE UNDER PRELIMINARY ACCEPTANCE OF THE ADAMS COUNTY DEPARTMENT OF PUBLIC WORKS.
- STATEMENT RESTRICTING ACCESS: A STATEMENT RESTRICTING ACCESS RIGHTS ACROSS THE RIGHT-OF-WAY LINES OF MAJOR HIGHWAYS, PARKWAYS, STREETS OR FREEWAYS, WHERE REQUIRED AS A PROVISION OF APPROVAL.
- STORM DRAINAGE FACILITIES STATEMENT:** THE POLICY OF THE COUNTY REQUIRES THAT MAINTENANCE ACCESS SHALL BE PROVIDED TO ALL STORM DRAINAGE FACILITIES TO ASSURE CONTINUOUS OPERATIONAL CAPABILITY OF THE SYSTEM. THE PROPERTY OWNER(S) SHALL BE RESPONSIBLE FOR THE MAINTENANCE OF ALL DRAINAGE FACILITIES INCLUDING INLET, PIPES, CULVERTS, CHANNELS, DITCHES, HYDRAULIC STRUCTURES, AND DETENTION BASINS LOCATED ON THEIR LAND UNLESS MODIFIED BY THE SUBDIVISION DEVELOPMENT AGREEMENT. SHOULD THE OWNER FAIL TO MAINTAIN SAID FACILITIES, THE COUNTY SHALL HAVE THE RIGHTS TO ENTER SAID LAND FOR THE SOLE PURPOSE OF OPERATIONS AND MAINTENANCE. ALL SUCH MAINTENANCE COST WILL BE ASSESSED TO THE PROPERTY OWNER(S).
- MONUMENTS, ORNAMENTAL COLUMNS, WINDOW WELLS, COUNTERFORTS, PATIOS, DECKS, RETAINING WALLS AND THEIR COMPONENTS ARE NOT PERMITTED TO ENCROACH INTO UTILITY EASEMENTS.
- THIS PLAT HEREBY DEDICATES A BLANKET ACCESS, DRAINAGE AND LANDSCAPE EASEMENT TO THE WOLF CREEK RUN WEST METRO DISTRICT OVER AND ACROSS TRACTS J, K, L, M, N, O, P AND Q.

## SURVEYOR'S CERTIFICATE

I, MARK A. GABERT, A DULY LICENSED PROFESSIONAL LAND SURVEYOR IN THE STATE OF COLORADO, DO HEREBY CERTIFY THAT THIS PLAT TRULY AND CORRECTLY REPRESENTS THE RESULTS OF A SURVEY MADE ON JANUARY 5, 2023, BY ME OR UNDER MY DIRECT SUPERVISION, THAT ALL MONUMENTS EXIST AS SHOWN HEREON AND THAT SAID PLAT ACCURATELY SHOWS THE SUBDIVISION DIMENSIONS AND DETAILS.

I ATTEST THE ABOVE ON \_\_\_\_\_, 202\_\_\_\_.

MARK A. GABERT  
 COLORADO PLS NO. 38567  
 FOR AND ON BEHALF OF MANHARD CONSULTING  
 7600 E. ORCHARD ROAD, SUITE 150-N  
 GREENWOOD VILLAGE, COLORADO 80111  
 303.531.3210

## CLERK AND RECORDER'S CERTIFICATE

THIS FINAL PLAT WAS FILED FOR RECORD IN THE OFFICE OF THE ADAMS COUNTY CLERK AND RECORDER, IN THE STATE OF COLORADO, AT \_\_\_\_\_ M., ON THIS \_\_\_\_\_ DAY OF \_\_\_\_\_ A.D. 202\_\_\_\_.

DEPUTY CLERK AND RECORDER \_\_\_\_\_

RECEPTION NUMBER \_\_\_\_\_

|   |         |
|---|---------|
| DRAWN BY  |         |
| REVISIONS   |         |
| DATE  |         |
| <br>Manhard CONSULTING<br>7600 East Orchard Road, Suite 150-N, Greenwood Village, CO 80111, ph:303.708.0500, manhard.com<br>Civil Engineering   Surveying & Geospatial Services   GIS   Water Resource Management |         |
| WOLF CREEK RUN WEST FILING NO. 2B<br>COUNTY OF ADAMS, STATE OF COLORADO<br>FINAL PLAT   |         |
| PROJ MGR.   | MAG     |
| PROJ ASC.   | MKW     |
| DRAWN BY.   | MKW     |
| DATE.   | 4/18/24 |
| SCALE.  | N/A     |
| SHEET<br><b>1</b> OF <b>8</b><br>EPL.ACCO.01  |         |

4/18/2024 10:42 AM Dwg Name: P:\Eplacco01.dwg Subdivision\Final Drawings\Plat of Subdivision\FZB\_Plat\1-Eplacco01-5110-FZB.dwg Updated By: MWood

# WOLF CREEK RUN WEST FILING NO. 2B

CASE NO.: PLT2024-

A REPLAT OF LOT 1, BLOCK 1 AND LOT 1, BLOCK 2, WOLF CREEK RUN WEST FILING NO. 2A,  
 LOCATED IN THE SOUTH HALF OF SECTION 29,  
 TOWNSHIP 3 SOUTH, RANGE 62 WEST OF THE SIXTH PRINCIPAL MERIDIAN,  
 COUNTY OF ADAMS, STATE OF COLORADO  
 SHEET 2 OF 8

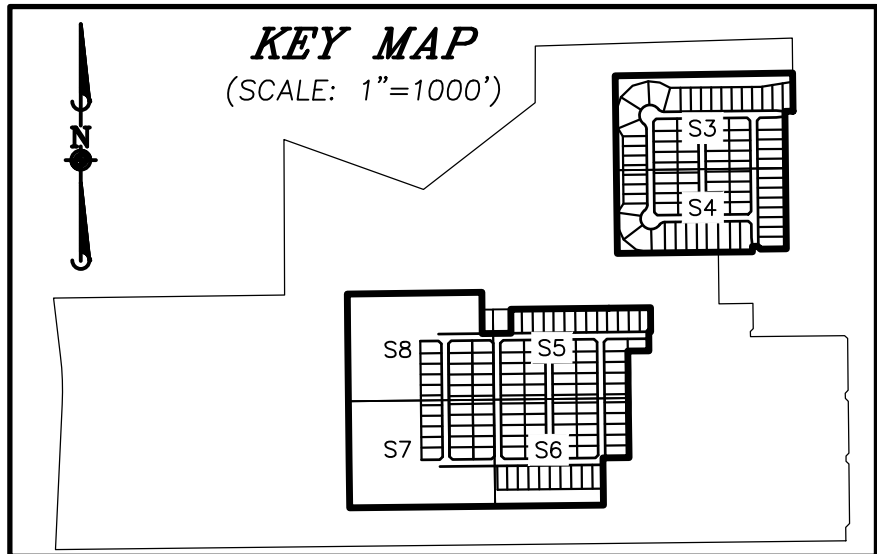

EAST QUARTER CORNER  
 SECTION 29, T3S, R62W  
 FOUND 3.25" ALUMINUM CAP  
 (ILLEGIBLE) 6" BELOW GROUND

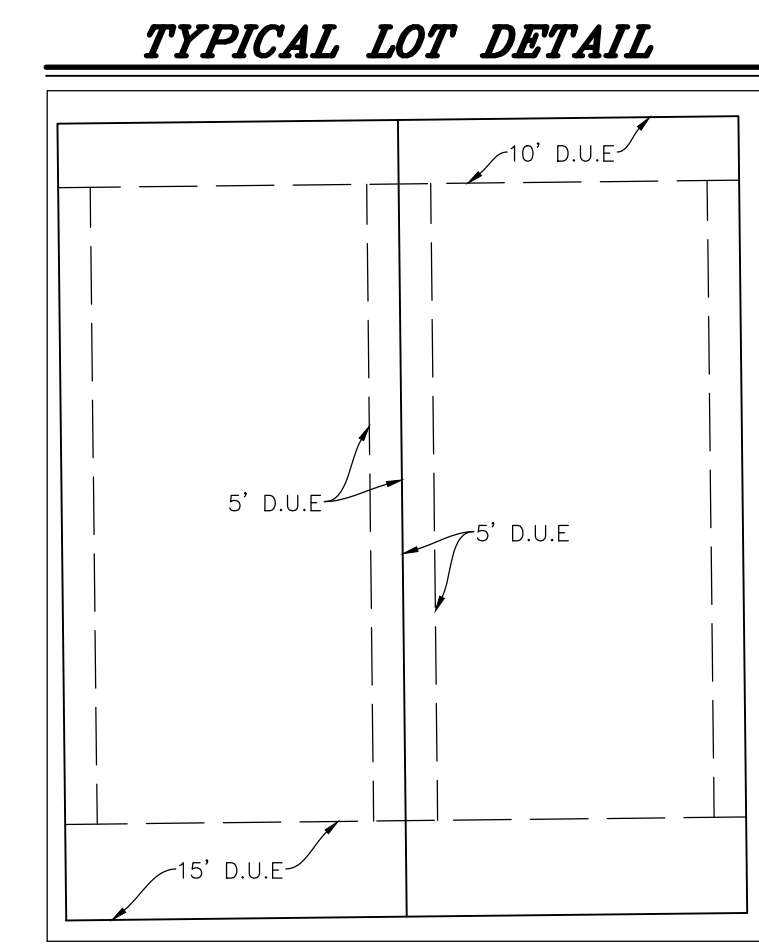

- ### LEGEND
- ◆ = FOUND SECTION CORNER AS NOTED
  - = FOUND SURVEY MONUMENT AS NOTED
  - ▲ = FOUND NAIL & 0.75" BRASS DISK (ILLEGIBLE)
  - = SET 1.25" YELLOW PLASTIC CAP STAMPED, "PLS 38567"
  - △ = SET NAIL & 0.75" BRASS DISK STAMPED, "PLS 38567"
  - # = BLOCK NUMBER
  - = SUBDIVISION BOUNDARY LINE
  - = PLATTED LOT LINE
  - = RIGHT OF WAY LINE
  - - - = SECTION LINE
  - - - = ADJOINING LOT LINE
  - - - = EASEMENT LINE HEREBY GRANTED
  - D.U.E. = DRAINAGE AND UTILITY EASEMENT HEREBY GRANTED

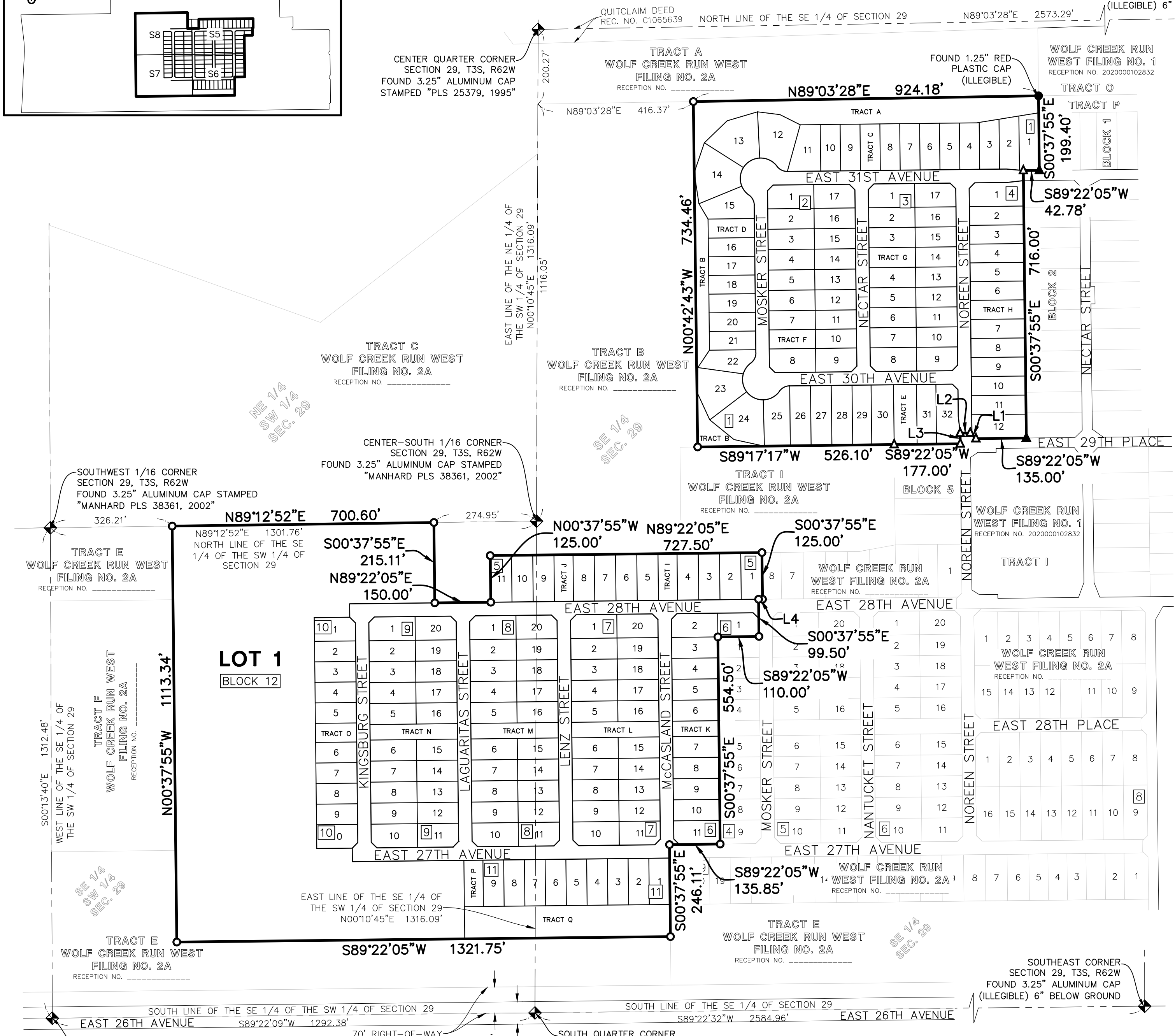
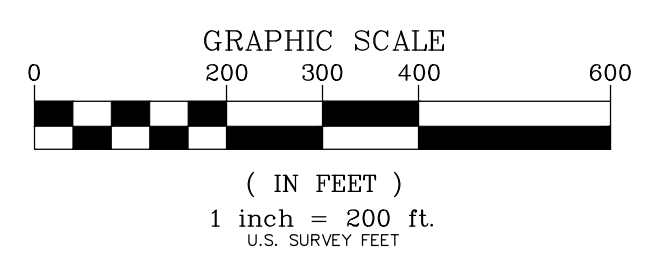

WEST 1/16TH CORNER  
 SECTION 29, T3S, R62W  
 FOUND 3.25" ALUMINUM CAP STAMPED  
 "MANHARD PLS 38361, 2002"

70' RIGHT-OF-WAY  
 DEDICATION RECEPTION  
 NO. \_\_\_\_\_

SOUTH QUARTER CORNER  
 SECTION 29, T3S, R62W  
 FOUND 3.25" ALUMINUM CAP  
 (ILLEGIBLE)

SOUTHEAST CORNER  
 SECTION 29, T3S, R62W  
 FOUND 3.25" ALUMINUM CAP  
 (ILLEGIBLE) 6" BELOW GROUND

FOR REVIEW ONLY

| <p>PROJ MGR. MAG</p> <p>PROJ ASC. MKW</p> <p>DRAWN BY. MKW</p> <p>DATE. 4/18/24</p> <p>SCALE. 1"=200'</p>  | <p>REVISIONS</p> <table border="1" style="width: 100%; border-collapse: collapse;"> <tr> <th>NO.</th> <th>DATE</th> <th>DESCRIPTION</th> </tr> <tr> <td> </td> <td> </td> <td> </td> </tr> <tr> <td> </td> <td> </td> <td> </td> </tr> </table> <p>DATE</p> | NO.         | DATE | DESCRIPTION |  |  |  |  |  |  |
|--|---|-------------|------|-------------|--|--|--|--|--|--|
| NO.  | DATE  | DESCRIPTION |      |             |  |  |  |  |  |  |
|  |   |             |      |             |  |  |  |  |  |  |
|  |   |             |      |             |  |  |  |  |  |  |
| <p><b>Manhard CONSULTING</b></p> <p>7600 East Orchard Road, Suite 150A, Greenwood Village, CO 80111, ph:303.708.0500, manhard.com</p> <p>Civil Engineering   Surveying &amp; Geospatial Services   GIS   Water Resource Management</p> |   |             |      |             |  |  |  |  |  |  |
| <p>WOLF CREEK RUN WEST FILING NO. 2B</p> <p>COUNTY OF ADAMS, STATE OF COLORADO</p> <p>FINAL PLAT</p>   |   |             |      |             |  |  |  |  |  |  |
| <p>SHEET 2 OF 8</p> <p>EPL.ACCO.01</p>   |   |             |      |             |  |  |  |  |  |  |

4/18/2024 10:42 AM Dwg Name: P:\Eplacco01.dwg\Surv\Final Drawings\Plat of Subdivision\FZB Plat 1--Eplacco01--5110--FZB.dwg Updated By: MWood

# WOLF CREEK RUN WEST FILING NO. 2B

A REPLAT OF LOT 1, BLOCK 1 AND LOT 1, BLOCK 2, WOLF CREEK RUN WEST FILING NO. 2A,  
 LOCATED IN THE SOUTH HALF OF SECTION 29,  
 TOWNSHIP 3 SOUTH, RANGE 62 WEST OF THE SIXTH PRINCIPAL MERIDIAN,  
 COUNTY OF ADAMS, STATE OF COLORADO  
 SHEET 3 OF 8

CASE NO.: PLT2024-

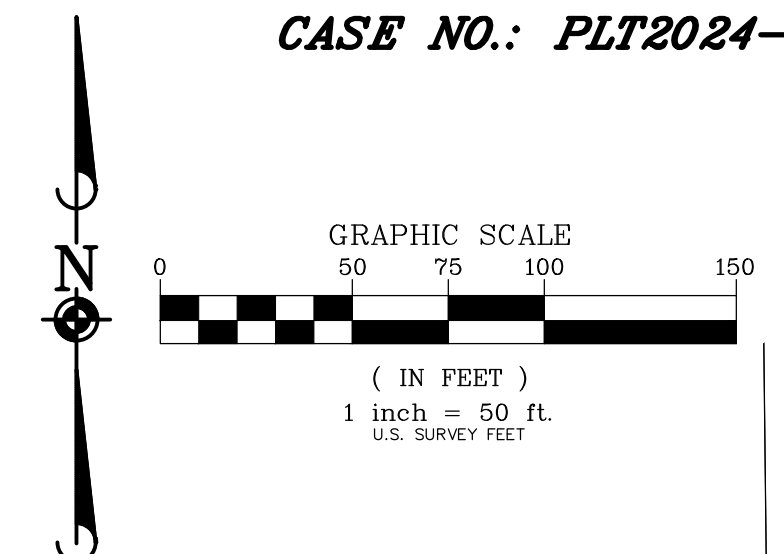
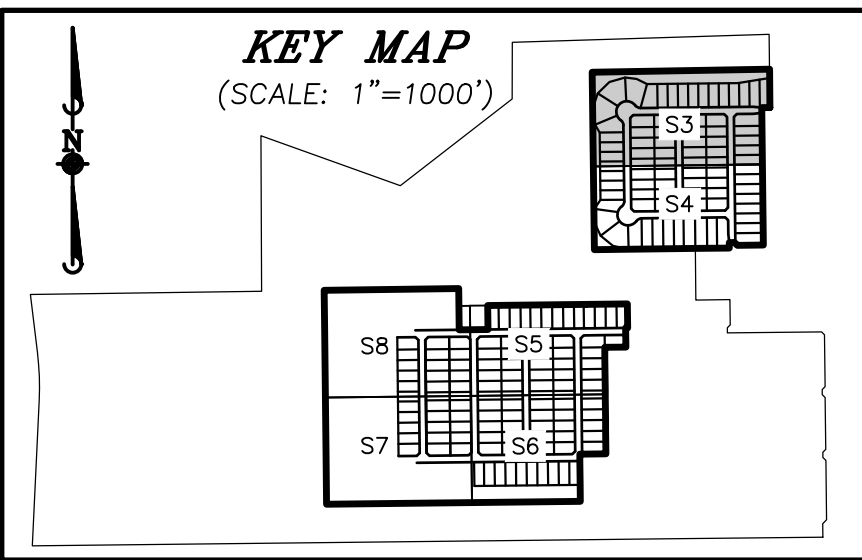

TRACT A  
 WOLF CREEK RUN  
 WEST FILING NO. 2A  
 RECEPTION NO. \_\_\_\_\_

N89°03'28"E 924.18'

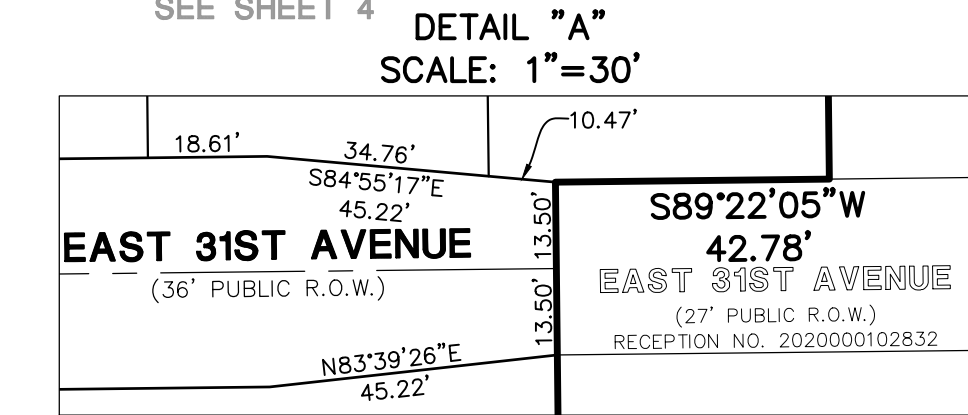

### LEGEND

- = SUBDIVISION BOUNDARY LINE
- = PLATTED LOT LINE
- = RIGHT OF WAY LINE
- - - = SECTION LINE
- - - = ADJOINING LOT LINE
- - - = EASEMENT LINE HEREBY GRANTED
- - - = DRAINAGE AND UTILITY EASEMENT HEREBY GRANTED

| CURVE TABLE |            |        |         |               |         |
|-------------|------------|--------|---------|---------------|---------|
| CURVE       | DELTA      | RADIUS | LENGTH  | CHORD BEARING | CHORD   |
| C1          | 90°00'00"  | 31.00' | 48.69'  | N44°22'05"E   | 43.84'  |
| C2          | 54°00'55"  | 34.00' | 32.05'  | S63°37'28"E   | 30.88'  |
| C3          | 198°01'49" | 54.50' | 188.37' | S44°22'05"W   | 107.65' |
| C4          | 54°00'55"  | 34.00' | 32.05'  | N27°38'23"W   | 30.88'  |

| LINE TABLE |             |        |
|------------|-------------|--------|
| LINE       | BEARING     | LENGTH |
| L22        | N44°22'05"E | 21.21' |
| L23        | S45°37'55"E | 21.21' |
| L24        | N44°22'05"E | 21.21' |
| L25        | N44°22'05"E | 21.21' |
| L26        | S45°37'55"E | 21.21' |

FOR REVIEW ONLY

| REVISIONS | DATE | DRAWN BY |
|-----------|------|----------|
|           |      |          |
|           |      |          |

**Manhard CONSULTING**  
 7600 East Orchard Road, Suite 150A, Greenwood Village, CO 80111, ph:303.708.0500, manhard.com  
 Civil Engineering | Surveying & Geospatial Services | GIS | Water Resource Management | Construction Management

WOLF CREEK RUN WEST FILING NO. 2B  
 COUNTY OF ADAMS, STATE OF COLORADO  
 FINAL PLAT

PROJ MGR. MAG  
 PROJ ENG. MKW  
 DRAWN BY. MKW  
 DATE. 4/18/24  
 SCALE. 1"=50'  
 SHEET 3 OF 8  
 EPL.ACCO.01

4/18/2024 10:59 AM Dwg Name: P:\Eplacco01\dwg\Surv\Final Drawings\Plat of Subdivision\F2B\Plat\_3--Eplacco01--5110--F2B.dwg Updated By: MWood

# WOLF CREEK RUN WEST FILING NO. 2B

CASE NO.: PLT2024-

A REPLAT OF LOT 1, BLOCK 1 AND LOT 1, BLOCK 2, WOLF CREEK RUN WEST FILING NO. 2A,  
 LOCATED IN THE SOUTH HALF OF SECTION 29,  
 TOWNSHIP 3 SOUTH, RANGE 62 WEST OF THE SIXTH PRINCIPAL MERIDIAN,  
 COUNTY OF ADAMS, STATE OF COLORADO  
 SHEET 4 OF 8

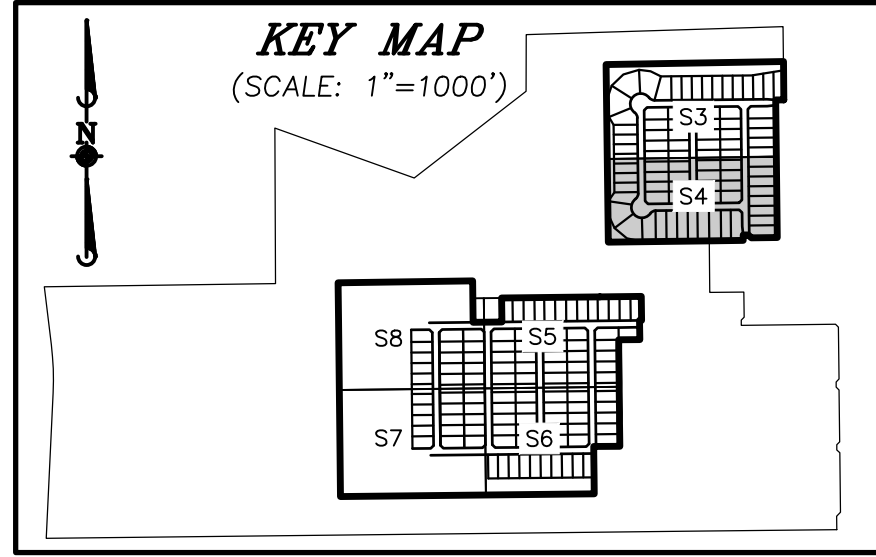

## LEGEND

- = SUBDIVISION BOUNDARY LINE
- = PLATTED LOT LINE
- = RIGHT OF WAY LINE
- = SECTION LINE
- = ADJOINING LOT LINE
- = EASEMENT LINE HEREBY GRANTED
- = DRAINAGE AND UTILITY EASEMENT HEREBY GRANTED

DETAIL "B"  
 SCALE: 1"=30'

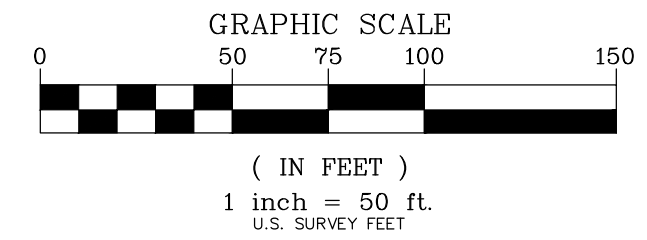
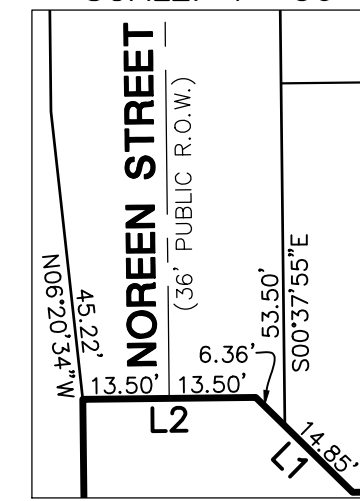

| REVISIONS | DATE | DRAWN BY |
|-----------|------|----------|
|           |      |          |
|           |      |          |
|           |      |          |
|           |      |          |

**Manhard CONSULTING**  
 7600 East Orchard Road, Suite 150A, Greenwood Village, CO 80111, ph:303.708.0500, manhard.com  
 Civil Engineering | Surveying & Geospatial Services | GIS  
 Water Resource Management | Construction Management

WOLF CREEK RUN WEST FILING NO. 2B  
 COUNTY OF ADAMS, STATE OF COLORADO  
**FINAL PLAT**

PROJ MGR. MAG  
 PROJ ENG. MKW  
 DRAWN BY. MKW  
 DATE. 4/18/24  
 SCALE. 1"=50'

SHEET  
**4** OF **8**  
 EPL.ACCO.01

FOR REVIEW ONLY

FOR AND ON BEHALF OF  
 MANHARD CONSULTING

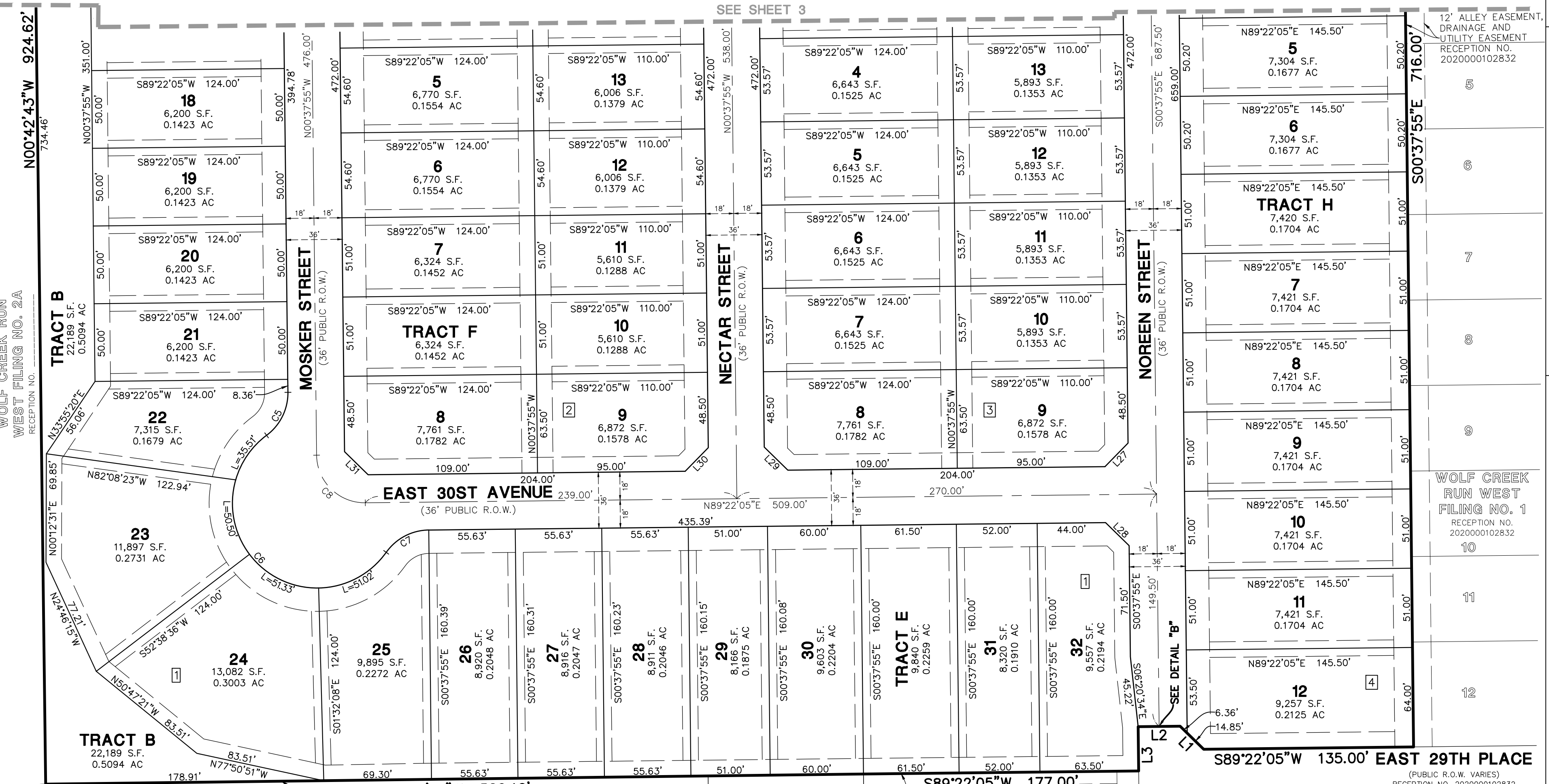

| CURVE TABLE |            |        |         |               |         |
|-------------|------------|--------|---------|---------------|---------|
| CURVE       | DELTA      | RADIUS | LENGTH  | CHORD BEARING | CHORD   |
| C5          | 54°00'55"  | 34.00' | 32.05'  | N26°22'32"E   | 30.88'  |
| C6          | 198°01'49" | 54.50' | 188.37' | S45°37'55"E   | 107.65' |
| C7          | 54°00'55"  | 34.00' | 32.05'  | S62°21'37"W   | 30.88'  |
| C8          | 90°00'00"  | 31.00' | 48.69'  | N45°37'55"W   | 43.84'  |

| LINE TABLE |             |        |      |             |        |
|------------|-------------|--------|------|-------------|--------|
| LINE       | BEARING     | LENGTH | LINE | BEARING     | LENGTH |
| L1         | N45°37'55"W | 21.21' | L28  | S45°37'55"E | 21.21' |
| L2         | S89°22'05"W | 27.00' | L29  | N45°37'55"W | 21.21' |
| L3         | S00°37'55"E | 28.50' | L30  | S44°22'05"W | 21.21' |
| L27        | S44°22'05"W | 21.21' | L31  | N45°37'55"W | 21.21' |

4/18/2024 10:59 AM Dwg Name: P:\Eplacoco01.dwg\Surf\Final Drawings\Plat of Subdivision\FZB Plat\FZB.dwg Updated By: MWood

# WOLF CREEK RUN WEST FILING NO. 2B

CASE NO.: PLT2024-

A REPLAT OF LOT 1, BLOCK 1 AND LOT 1, BLOCK 2, WOLF CREEK RUN WEST FILING NO. 2A,  
 LOCATED IN THE SOUTH HALF OF SECTION 29,  
 TOWNSHIP 3 SOUTH, RANGE 62 WEST OF THE SIXTH PRINCIPAL MERIDIAN,  
 COUNTY OF ADAMS, STATE OF COLORADO  
 SHEET 5 OF 8

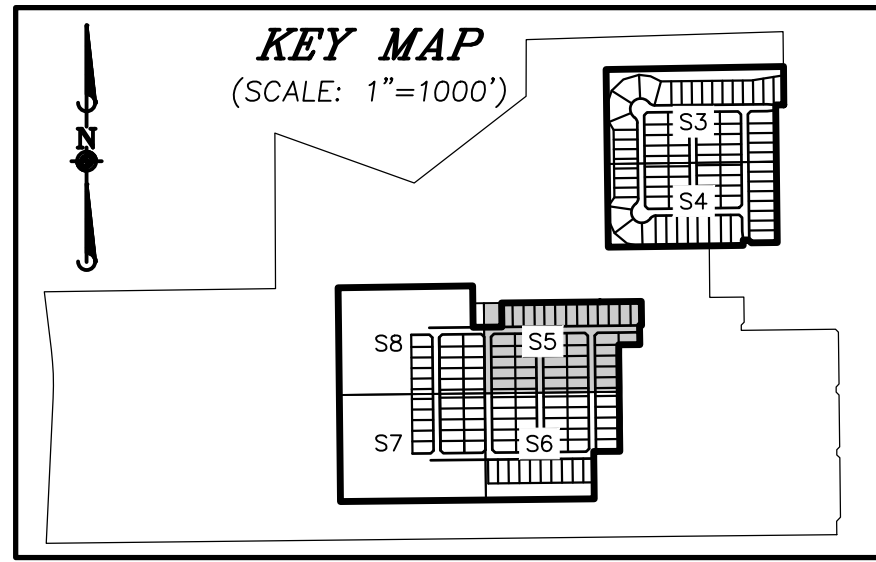

DETAIL "C"  
 SCALE: 1"=30'

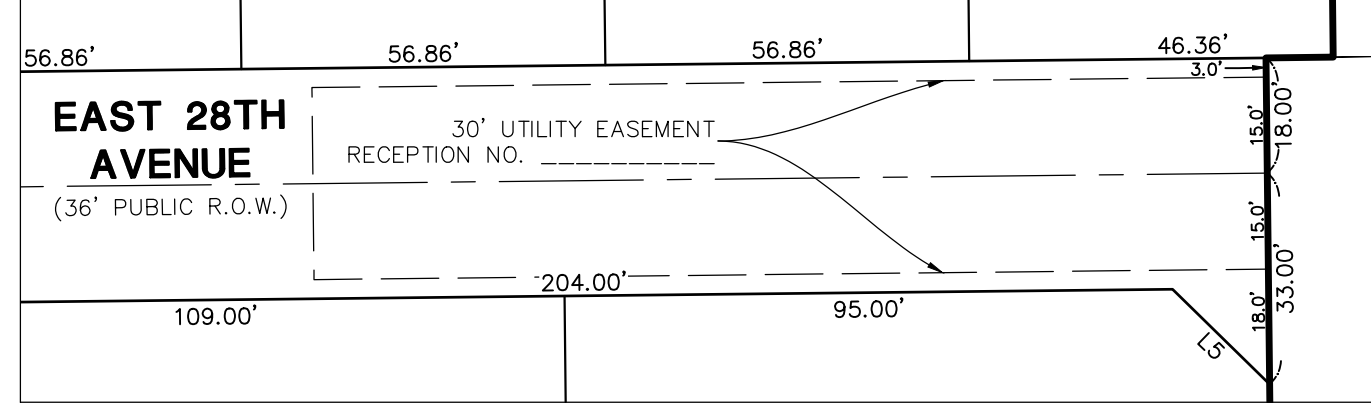

## LEGEND

- = SUBDIVISION BOUNDARY LINE
- = PLATTED LOT LINE
- = RIGHT OF WAY LINE
- = SECTION LINE
- = ADJOINING LOT LINE
- = EASEMENT LINE HEREBY GRANTED
- D.U.E. = DRAINAGE AND UTILITY EASEMENT HEREBY GRANTED

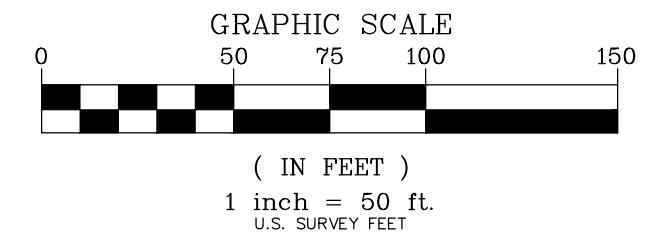

TRACT B  
 WOLF CREEK RUN WEST FILING NO. 2A  
 RECEPTION NO. \_\_\_\_\_

TRACT H  
 WOLF CREEK RUN WEST FILING NO. 2A  
 RECEPTION NO. \_\_\_\_\_

5' DRAINAGE AND UTILITY EASEMENT RECORDED BY SEPARATE DOCUMENT

5' DRAINAGE AND UTILITY EASEMENT RECEPTION NO. \_\_\_\_\_

10' DRAINAGE AND UTILITY EASEMENT RECEPTION NO. \_\_\_\_\_

WOLF CREEK RUN WEST FILING NO. 2A  
 RECEPTION NO. \_\_\_\_\_

15' DRAINAGE AND UTILITY EASEMENT RECEPTION NO. \_\_\_\_\_

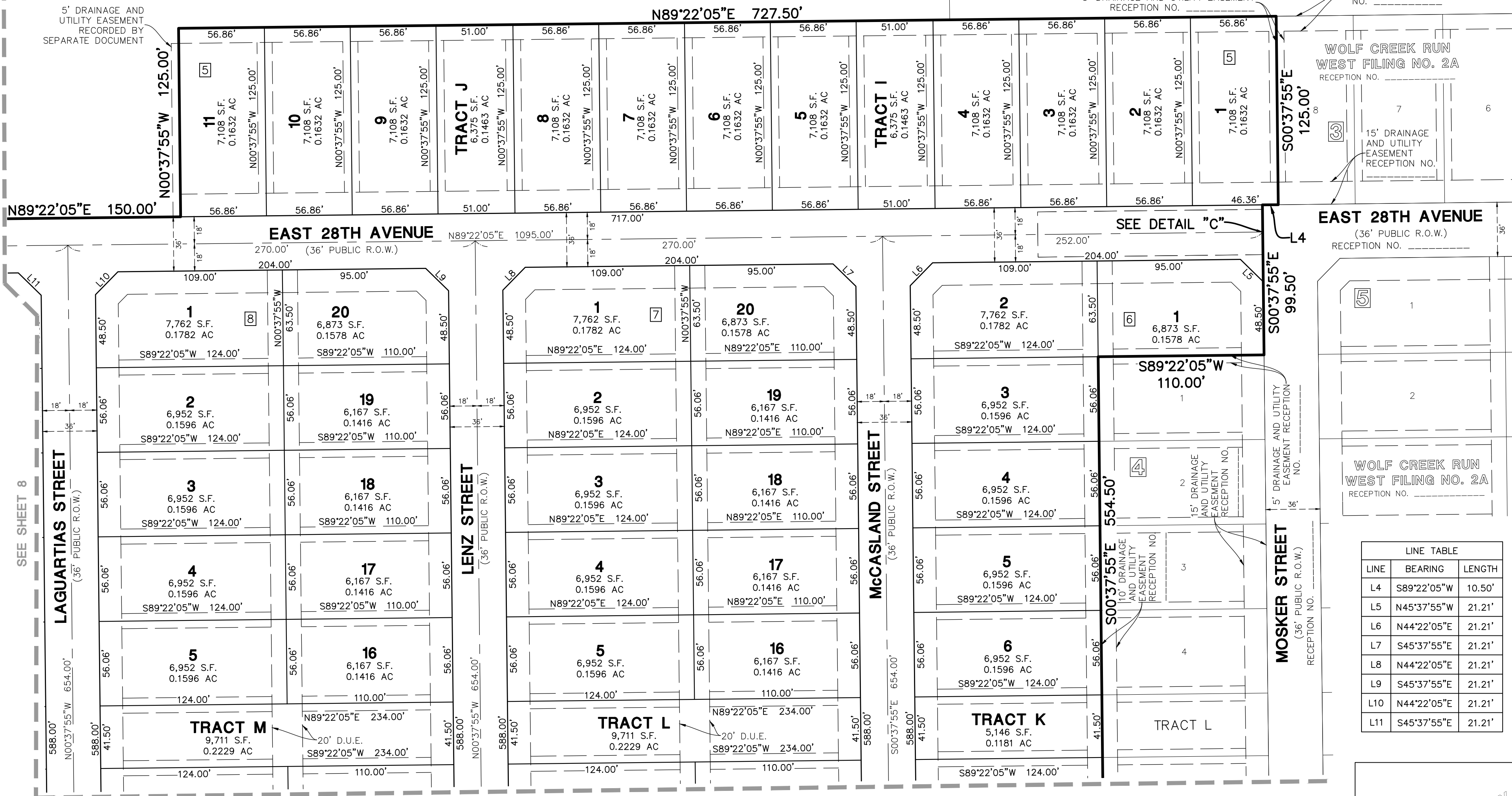

| LINE TABLE |             |        |
|------------|-------------|--------|
| LINE       | BEARING     | LENGTH |
| L4         | S89°22'05"W | 10.50' |
| L5         | N45°37'55"W | 21.21' |
| L6         | N44°22'05"E | 21.21' |
| L7         | S45°37'55"E | 21.21' |
| L8         | N44°22'05"E | 21.21' |
| L9         | S45°37'55"E | 21.21' |
| L10        | N44°22'05"E | 21.21' |
| L11        | S45°37'55"E | 21.21' |

SEE SHEET 6

**Manhard CONSULTING**  
 7600 East Orchard Road, Suite 150A, Greenwood Village, CO 80111, ph:303.708.0500, manhard.com  
 Civil Engineering | Surveying & Geospatial Services | GIS | Construction Management | Water Resource Management

**WOLF CREEK RUN WEST FILING NO. 2B**  
 COUNTY OF ADAMS, STATE OF COLORADO  
**FINAL PLAT**

PROJ MGR. MAG  
 PROJ ENG. MKW  
 DRAWN BY. MKW  
 DATE. 4/18/24  
 SCALE. 1"=50'

SHEET **5** OF **8**  
 EPL.ACCO.01

FOR REVIEW ONLY

FOR AND ON BEHALF OF  
 MANHARD CONSULTING

4/18/2024 10:59 AM Dwg Name: P:\Eplacco01.dwg Final Drawings\Plat of Subdivision\FZB Plat 3--Eplacco01--5110--FZB.dwg Updated By: MWood

# WOLF CREEK RUN WEST FILING NO. 2B

CASE NO.: PLT2024-

A REPLAT OF LOT 1, BLOCK 1 AND LOT 1, BLOCK 2, WOLF CREEK RUN WEST FILING NO. 2A,  
 LOCATED IN THE SOUTH HALF OF SECTION 29,  
 TOWNSHIP 3 SOUTH, RANGE 62 WEST OF THE SIXTH PRINCIPAL MERIDIAN,  
 COUNTY OF ADAMS, STATE OF COLORADO  
 SHEET 6 OF 8

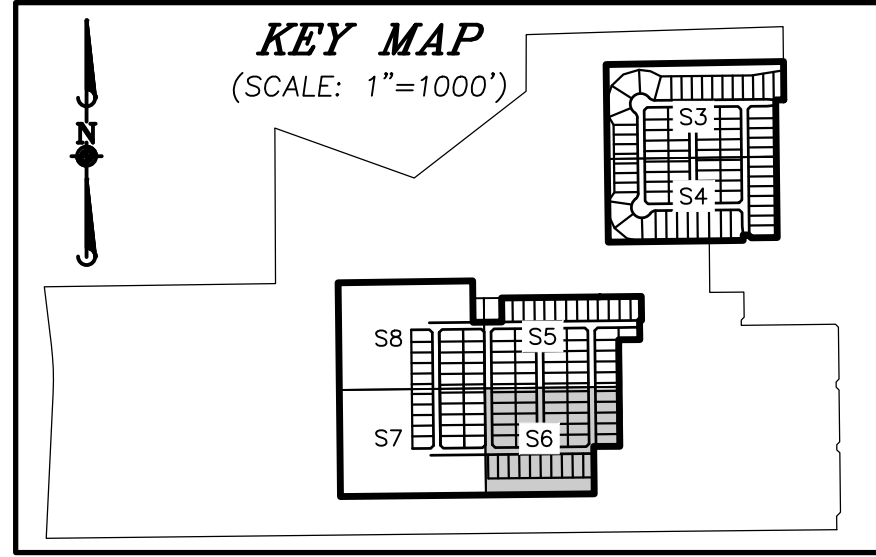

- ### LEGEND
- = SUBDIVISION BOUNDARY LINE
  - = PLATTED LOT LINE
  - = RIGHT OF WAY LINE
  - = SECTION LINE
  - = ADJOINING LOT LINE
  - = EASEMENT LINE HEREBY GRANTED
  - = DRAINAGE AND UTILITY EASEMENT HEREBY GRANTED

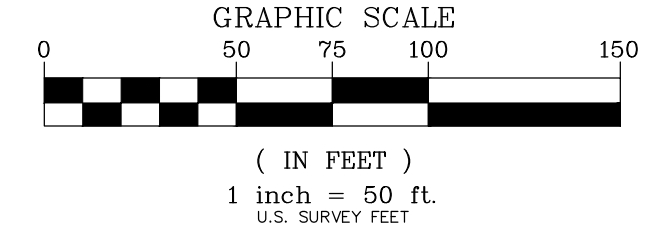

SEE SHEET 5



| LINE TABLE |             |        |
|------------|-------------|--------|
| LINE       | BEARING     | LENGTH |
| L14        | S45°37'55"E | 21.21' |
| L15        | S44°22'05"W | 21.21' |
| L16        | N45°37'55"W | 21.21' |
| L17        | N44°22'05"E | 21.21' |
| L18        | S45°37'55"E | 21.21' |
| L19        | N44°22'05"E | 21.21' |

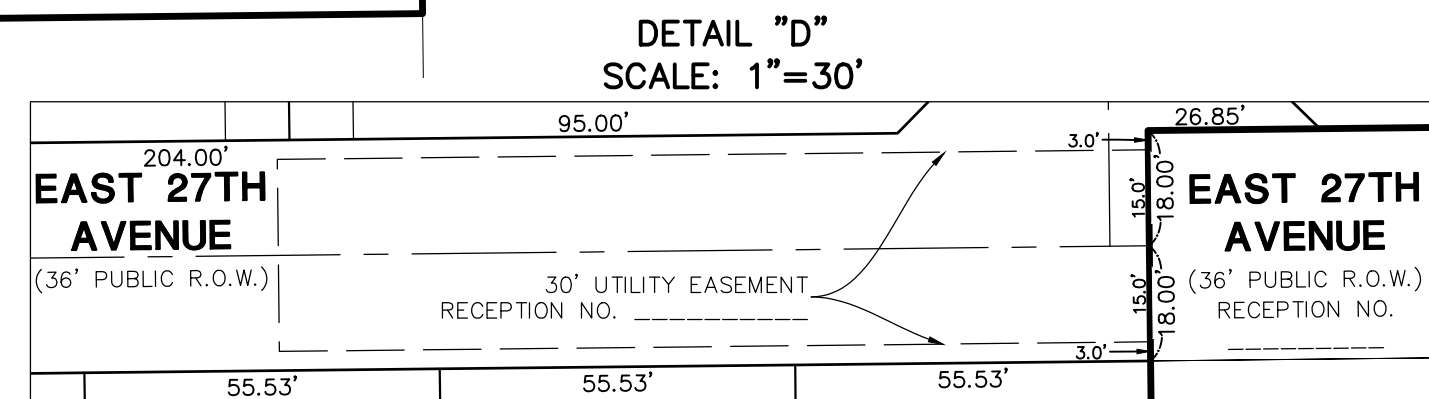

FOR REVIEW ONLY

FOR AND ON BEHALF OF MANHARD CONSULTING

| REVISIONS | DATE | DRAWN BY |
|-----------|------|----------|
|           |      |          |
|           |      |          |

**WOLF CREEK RUN WEST FILING NO. 2B**  
**COUNTY OF ADAMS, STATE OF COLORADO**  
**FINAL PLAT**

PROJ MGR. MAG  
 PROJ ENG. MKW  
 DRAWN BY. MKW  
 DATE. 4/18/24  
 SCALE. 1"=50'

SHEET **6** OF **8**  
 EPL.ACCO.01

4/18/2024 10:59 AM Dwg Name: P:\Eplacco01\Draws\Final Drawings\Plat of Subdivision\FZB Plat\FZB.dwg Updated By: MWood

# WOLF CREEK RUN WEST FILING NO. 2B

CASE NO.: PLT2024-

A REPLAT OF LOT 1, BLOCK 1 AND LOT 1, BLOCK 2, WOLF CREEK RUN WEST FILING NO. 2A,  
 LOCATED IN THE SOUTH HALF OF SECTION 29,  
 TOWNSHIP 3 SOUTH, RANGE 62 WEST OF THE SIXTH PRINCIPAL MERIDIAN,  
 COUNTY OF ADAMS, STATE OF COLORADO  
 SHEET 7 OF 8

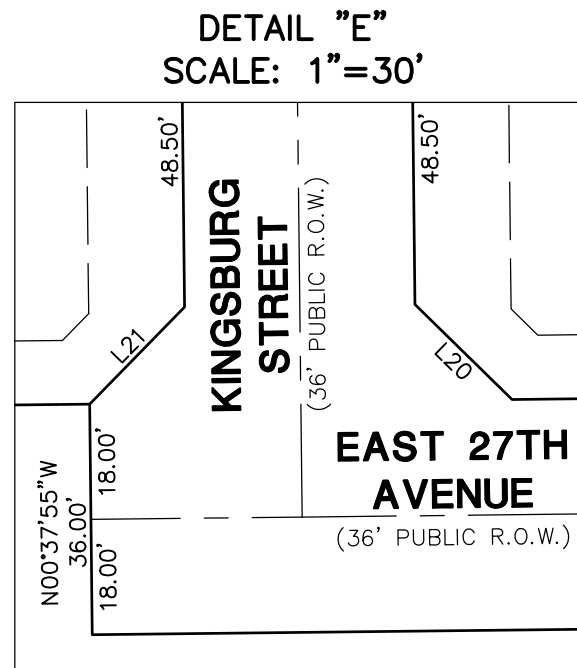
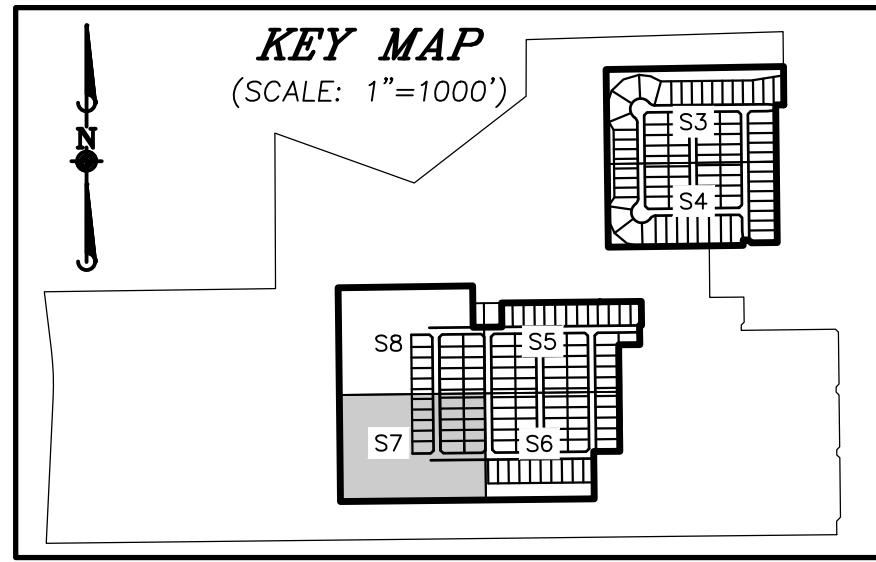

**LEGEND**

- = SUBDIVISION BOUNDARY LINE
- = PLATTED LOT LINE
- = RIGHT OF WAY LINE
- = SECTION LINE
- = ADJOINING LOT LINE
- = EASEMENT LINE HEREBY GRANTED
- = DRAINAGE AND UTILITY EASEMENT HEREBY GRANTED

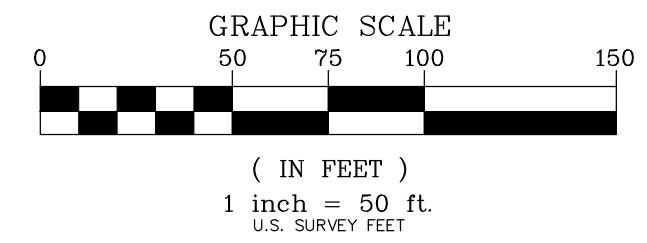

TRACT F  
 WOLF CREEK RUN WEST FILING NO. 2A  
 RECEPTION NO. N00°37'55"W 1113.34'

TRACT E  
 WOLF CREEK RUN WEST FILING NO. 2A  
 RECEPTION NO. \_\_\_\_\_

30' DRAINAGE EASEMENT  
 RECEPTION NO. \_\_\_\_\_

1  
 579,419 S.F.  
 13.3016 AC  
 BLOCK 12

SEE SHEET 8

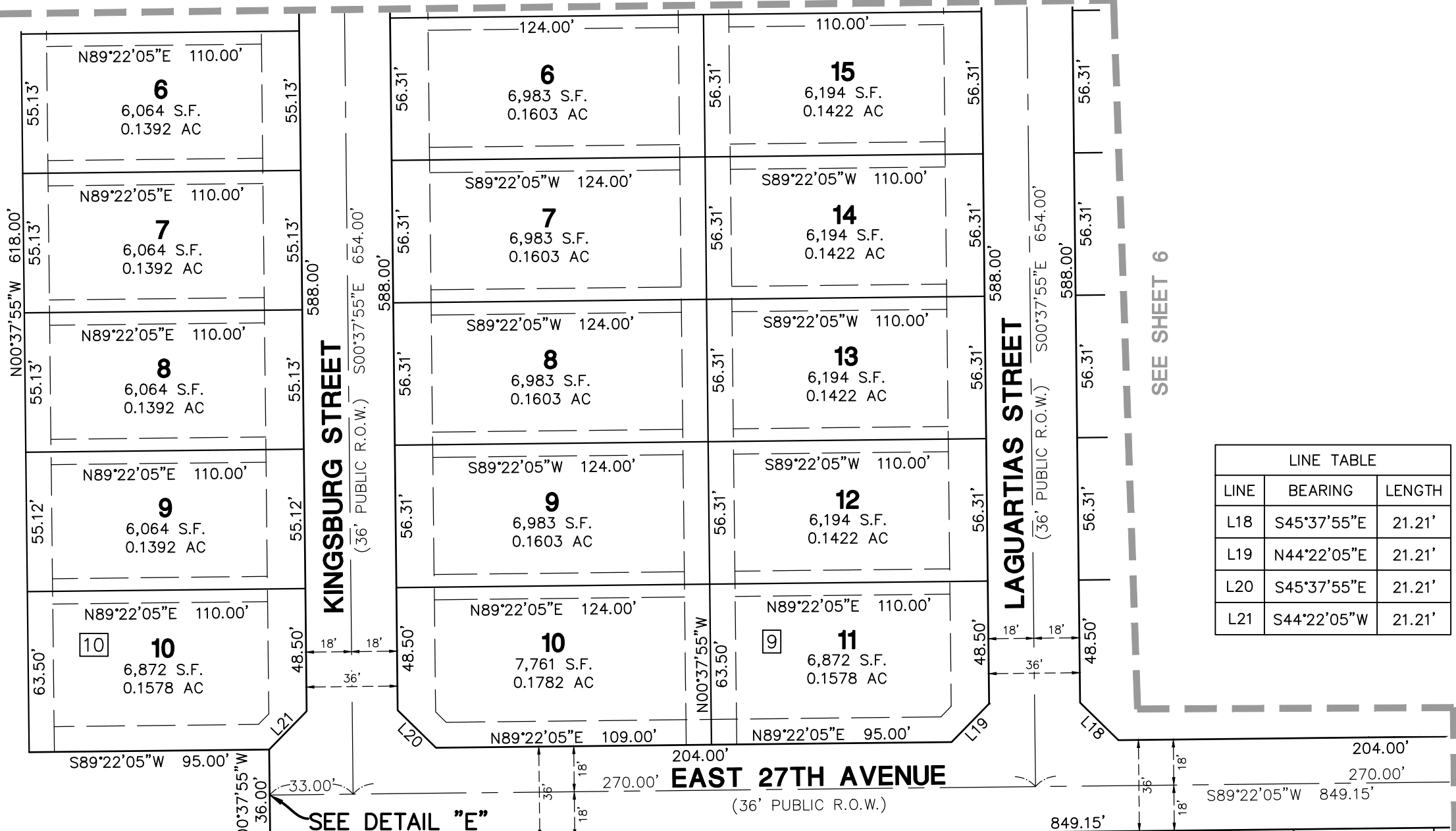

LINE TABLE

| LINE | BEARING     | LENGTH |
|------|-------------|--------|
| L18  | S45°37'55"E | 21.21' |
| L19  | N44°22'05"E | 21.21' |
| L20  | S45°37'55"E | 21.21' |
| L21  | S44°22'05"W | 21.21' |

1  
 579,419 S.F.  
 13.3016 AC  
 BLOCK 12

SEE SHEET 6

TRACT P  
 6,524 S.F.  
 0.1452 AC

TRACT Q  
 47,428 S.F.  
 1.0888 AC

FOR REVIEW ONLY

TRACT E  
 WOLF CREEK RUN WEST FILING NO. 2A  
 RECEPTION NO. \_\_\_\_\_

S89°22'05"W 1321.75'

FOR AND ON BEHALF OF  
 MANHARD CONSULTING

**Manhard CONSULTING**  
 7600 East Orchard Road, Suite 150A, Greenwood Village, CO 80111, ph:303.708.0500, manhard.com  
 Civil Engineering | Surveying & Geospatial Services | GIS | Water Resource Management | Construction Management

WOLF CREEK RUN WEST FILING NO. 2B  
 COUNTY OF ADAMS, STATE OF COLORADO  
 FINAL PLAT

PROJ MGR. MAG  
 PROJ ENG. MKW  
 DRAWN BY. MKW  
 DATE. 4/18/24  
 SCALE. 1"=50'

SHEET 7 OF 8  
 EPL.ACCO.01



# WOLF CREEK RUN WEST FILING NO. 2B

CASE NO.: PLT2024-

A REPLAT OF LOT 1, BLOCK 1 AND LOT 1, BLOCK 2, WOLF CREEK RUN WEST FILING NO. 2A,  
 LOCATED IN THE SOUTH HALF OF SECTION 29,  
 TOWNSHIP 3 SOUTH, RANGE 62 WEST OF THE SIXTH PRINCIPAL MERIDIAN,  
 COUNTY OF ADAMS, STATE OF COLORADO  
 SHEET 8 OF 8

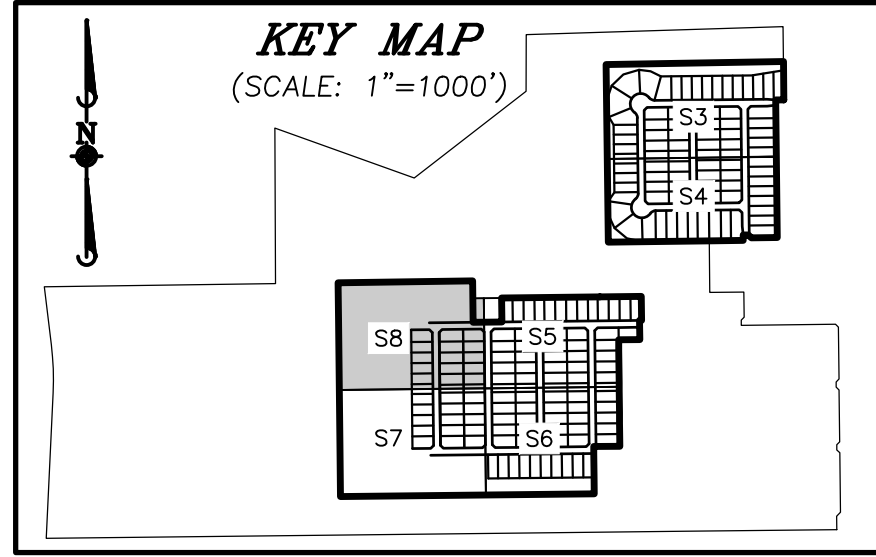

## LEGEND

- = SUBDIVISION BOUNDARY LINE
- = PLATTED LOT LINE
- = RIGHT OF WAY LINE
- = SECTION LINE
- = ADJOINING LOT LINE
- = EASEMENT LINE HEREBY GRANTED
- = DRAINAGE AND UTILITY EASEMENT HEREBY GRANTED

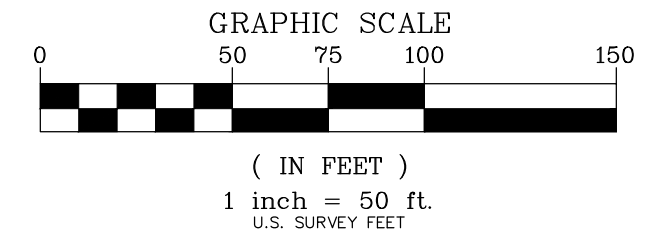

DETAIL "F"  
 SCALE: 1"=30'

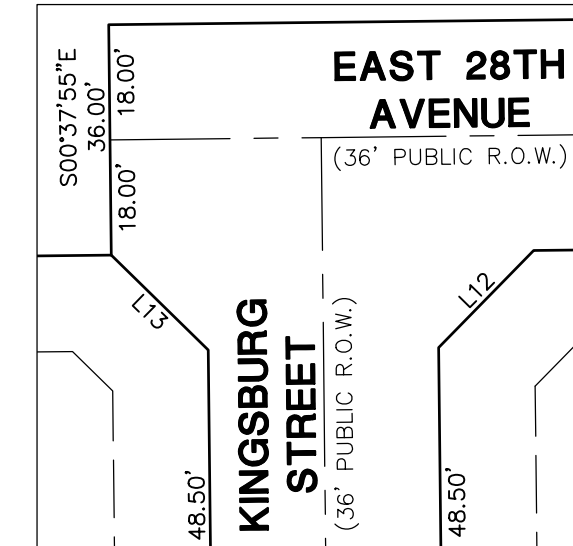

TRACT C  
 WOLF CREEK RUN WEST FILING NO. 2A  
 RECEPTION NO. \_\_\_\_\_

N89°12'52"E 700.60'

**1**  
 579,419 S.F.  
 13.3016 AC  
 BLOCK 12

TRACT B  
 WOLF CREEK RUN WEST  
 FILING NO. 2A  
 RECEPTION NO. \_\_\_\_\_

N89°22'05"E 150.00'

EAST 28TH AVENUE  
 (36' PUBLIC R.O.W.)

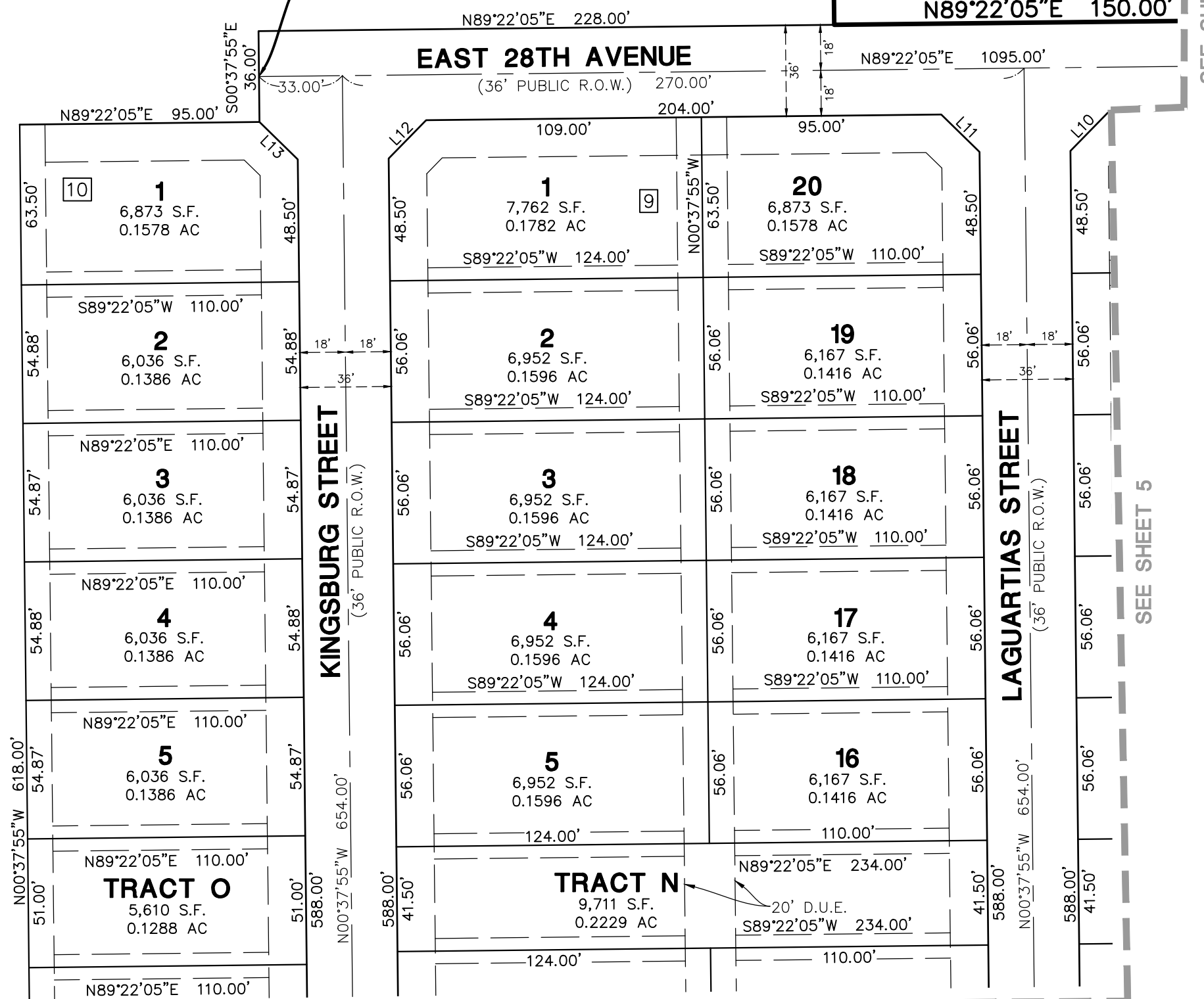

| LINE TABLE |             |        |
|------------|-------------|--------|
| LINE       | BEARING     | LENGTH |
| L12        | N44°22'05"E | 21.21' |
| L13        | S45°37'55"E | 21.21' |

FOR REVIEW ONLY

FOR AND ON BEHALF OF  
 MANHARD CONSULTING

TRACT E  
 WOLF CREEK RUN WEST FILING NO. 2A  
 RECEPTION NO. \_\_\_\_\_

TRACT F  
 WOLF CREEK RUN WEST FILING NO. 2A  
 RECEPTION NO. \_\_\_\_\_

N00°37'55"W 1113.34'

**1**  
 579,419 S.F.  
 13.3016 AC  
 BLOCK 12

SEE SHEET 7

SEE SHEET 5

SEE SHEET 5

|  |         |           |  |      |  |
|--|---------|-----------|--|------|--|
| DRAWN BY   |         | REVISIONS |  | DATE |  |
| <p><b>Manhard CONSULTING</b><br/>                 7600 East Orchard Road, Suite 150A, Greenwood Village, CO 80111, ph:303.708.0500, manhard.com<br/>                 Civil Engineering   Surveying &amp; Geospatial Services   GIS   Water Resource Management   Construction Management</p> |         |           |  |      |  |
| <p><b>WOLF CREEK RUN WEST FILING NO. 2B</b><br/>                 COUNTY OF ADAMS, STATE OF COLORADO<br/> <b>FINAL PLAT</b></p>   |         |           |  |      |  |
| PROJ MGR.  | MAG     |           |  |      |  |
| PROJ ENG.  | MKW     |           |  |      |  |
| DRAWN BY.  | MKW     |           |  |      |  |
| DATE.  | 4/18/24 |           |  |      |  |
| SCALE.   | 1"=50'  |           |  |      |  |
| SHEET  |         |           |  |      |  |
| <b>8</b>   |         |           |  |      |  |
| OF   |         |           |  |      |  |
| <b>8</b>   |         |           |  |      |  |
| EPL.ACCO.01  |         |           |  |      |  |

4/18/2024 10:59 AM Dwg Name: P:\Eplacco01\Drawings\Final Drawings\Final Drawings\FZB Plat\FZB.dwg Updated By: MWood

# Parcel Map Check Report

**Prepared by:**

Manhard Consulting

Date: 4/19/2024 9:36:36 AM

---

Parcel Name: WCRW F2B - BOUNDARY - BOUNDARY 1

Process segment order counterclockwise: False

Enable mapcheck across chord: False

North: 703,031.0910'

East: 324,862.3718'

Segment# 1: Line

Course: N0°42'43"W

Length: 924.62'

North: 703,955.6396'

East: 324,850.8829'

Segment# 2: Line

Course: N89°03'28"E

Length: 924.18'

North: 703,970.8369'

East: 325,774.9380'

Segment# 3: Line

Course: S0°37'55"E

Length: 199.40'

North: 703,771.4491'

East: 325,777.1372'

Segment# 4: Line

Course: S89°22'05"W

Length: 42.78'

North: 703,770.9772'

East: 325,734.3598'

Segment# 5: Line

Course: S0°37'55"E

Length: 716.00'

North: 703,055.0208'

East: 325,742.2568'

Segment# 6: Line

Course: S89°22'05"W

Length: 135.00'

North: 703,053.5318'

East: 325,607.2650'

Segment# 7: Line



Segment# 3: Line  
Course: S0°37'55"E Length: 215.11'  
North: 702,613.8799' East: 324,158.5255'

Segment# 4: Line  
Course: N89°22'05"E Length: 150.00'  
North: 702,615.5343' East: 324,308.5163'

Segment# 5: Line  
Course: N0°37'55"W Length: 125.00'  
North: 702,740.5267' East: 324,307.1377'

Segment# 6: Line  
Course: N89°22'05"E Length: 727.50'  
North: 702,748.5505' East: 325,034.5934'

Segment# 7: Line  
Course: S0°37'55"E Length: 125.00'  
North: 702,623.5581' East: 325,035.9721'

Segment# 8: Line  
Course: S89°22'05"W Length: 10.50'  
North: 702,623.4423' East: 325,025.4727'

Segment# 9: Line  
Course: S0°37'55"E Length: 99.50'  
North: 702,523.9484' East: 325,026.5701'

Segment# 10: Line  
Course: S89°22'05"W Length: 110.00'  
North: 702,522.7352' East: 324,916.5768'

Segment# 11: Line  
Course: S0°37'55"E Length: 554.50'  
North: 701,968.2689' East: 324,922.6926'

Segment# 12: Line  
Course: S89°22'05"W Length: 135.85'

North: 701,966.7706'

East: 324,786.8508'

Segment# 13: Line

Course: S0°37'55"E

North: 701,720.6755'

Length: 246.11'

East: 324,789.5652'

Segment# 14: Line

Course: S89°22'05"W

North: 701,706.0976'

Length: 1,321.75'

East: 323,467.8956'

Perimeter: 5,634.76'

Error Closure: 0.0030

Error North : -0.00171

Area: 1,530,498Sq.Ft.

Course: S55°39'29"W

East: -0.00250

Precision 1: 1,878,253.33





## Customer Distribution



**Prevent fraud** - Please call a member of our closing team for wire transfer instructions or to initiate a wire transfer. Note that our wiring instructions will never change.

Order Number: **ABC70779829.1**

Date: **03/27/2024**

Property Address: **NW CORNER EAST 26TH AVE AND PIGGOTT ROAD, STRASBURG, CO**

### For Closing Assistance

Colin Snody  
3033 EAST FIRST AVENUE,  
SUITE 600  
DENVER, CO 80206  
(303) 331-6234 (Work)  
(303) 393-3806 (Work Fax)  
[csnody@ltgc.com](mailto:csnody@ltgc.com)  
Contact License: CO271428  
Company License: CO44565

### Closer's Assistant

Megan Corbin  
3033 EAST FIRST AVENUE,  
SUITE 600  
DENVER, CO 80206  
(303) 331-6291 (Work)  
(303) 393-3865 (Work Fax)  
[mcorbin@ltgc.com](mailto:mcorbin@ltgc.com)  
Company License: CO44565

### For Title Assistance

Scott Bennetts  
5975 GREENWOOD PLAZA  
BLVD  
GREENWOOD VILLAGE, CO  
80111  
(303) 850-4175 (Work)  
[sbennetts@ltgc.com](mailto:sbennetts@ltgc.com)

### EAST PEAK LAND DEVELOPMENT COMPANY LLC DREW WHITE

Attention: CARLTON BABBS  
1771 S HUMBOLDT STREET  
DENVER, CO 80210  
(303) 881-8962 (Work)  
[cbabbs@eastpeakland.com](mailto:cbabbs@eastpeakland.com)  
Delivered via: Electronic Mail

[dwhite@cassidyholdingsfl.com](mailto:dwhite@cassidyholdingsfl.com)  
Delivered via: Electronic Mail

### FOSTER GRAHAM MILSTEIN AND CALISHER LLP RICK MOORE

Attention: ERIK CARLSON  
360 S GARFIELD 6TH FLOOR  
DENVER, CO 80209  
(303) 333-9810 (Work)  
(303) 333-9786 (Work Fax)  
[ecarlson@fostergraham.com](mailto:ecarlson@fostergraham.com)  
Delivered via: Electronic Mail

[rmoore@manhard.com](mailto:rmoore@manhard.com)  
Delivered via: Electronic Mail

### FOSTER GRAHAM MILSTEIN AND CALISHER LLP JULIE RENTZ

Attention: DREW DEMERS  
360 S GARFIELD 6TH FLOOR  
DENVER, CO 80209  
(303) 333-9810 (Work)  
[ddemers@fostergraham.com](mailto:ddemers@fostergraham.com)  
Delivered via: Electronic Mail

[jrentz@manhard.com](mailto:jrentz@manhard.com)  
Delivered via: Electronic Mail

DANIEL ARNETTE  
daniel@cassidylanddev.com  
Delivered via: Electronic Mail

CHRIS SHANDOR  
cshandor@manhard.com  
Delivered via: Electronic Mail

KEVIN CHINOY  
kchinoy@cassidylanddev.com  
Delivered via: Electronic Mail





## Estimate of Title Fees

**Order Number:** ABC70779829.1

**Date:** 03/27/2024

**Property Address:** NW CORNER EAST 26TH AVE AND PIGGOTT ROAD, STRASBURG, CO

**Seller(s):** WOLF CREEK RUN WEST LLC, A COLORADO LIMITED LIABILITY COMPANY

**Buyer(s):** A BUYER TO BE DETERMINED

Thank you for putting your trust in Land Title. Below is the estimate of title fees for the transaction. The final fees will be collected at closing. Visit [ltgc.com](http://ltgc.com) to learn more about Land Title.

| Estimate of Title Insurance Fees |               |
|----------------------------------|---------------|
| "ALTA" Owner's Policy 07-30-21   | \$0.00        |
| <b>TOTAL</b>                     | <b>\$0.00</b> |

**Note:** The documents linked in this commitment should be reviewed carefully. These documents, such as covenants conditions and restrictions, may affect the title, ownership and use of the property. You may wish to engage legal assistance in order to fully understand and be aware of the implications of the documents on your property.

**Chain of Title Documents:**

[Adams county recorded 01/31/2024 under reception no. 202400005094](#)

[Adams county recorded 06/25/2001 under reception no. C0818983](#)

**ALTA COMMITMENT**

**Old Republic National Title Insurance Company**

**Schedule A**

Order Number: ABC70779829.1

**Property Address:**

NW CORNER EAST 26TH AVE AND PIGGOTT ROAD, STRASBURG, CO

**1. Commitment Date:**

03/22/2024 at 5:00 P.M.

**2. Policy to be Issued and Proposed Insured:**

"ALTA" Owner's Policy 07-30-21

\$0.00

Proposed Insured:

A BUYER TO BE DETERMINED

**3. The estate or interest in the land described or referred to in this Commitment and covered herein is:**

A FEE SIMPLE

**4. The Title is, at the Commitment Date, vested in:**

WOLF CREEK RUN WEST LLC, A COLORADO LIMITED LIABILITY COMPANY

**5. The Land is described as follows:**

A TRACT OF LAND BEING A PORTION OF THE SOUTH HALF (S1/2) OF SECTION 29, TOWNSHIP 3 SOUTH, RANGE 62 WEST OF THE SIXTH PRINCIPAL MERIDIAN, COUNTY OF ADAMS, STATE OF COLORADO, MORE PARTICULARLY DESCRIBED AS FOLLOWS:

COMMENCING AT THE CENTER QUARTER CORNER OF SAID SECTION 29, THENCE SOUTH 00°10'45" WEST, A DISTANCE OF 37.70 FEET TO THE SOUTH LINE OF THAT PARCEL OF LAND AS DESCRIBED IN QUITCLAIM DEED RECORDED AT RECEPTION NUMBER C-1065639 IN THE RECORDS OF THE ADAMS COUNTY CLERK AND RECORDER'S OFFICE AND BEING THE POINT OF BEGINNING;

THENCE NORTH 88°13'23" EAST, ALONG SAID SOUTH LINE, A DISTANCE OF 1,338.50 FEET TO THE NORTHWEST CORNER OF TRACT O, WOLF CREEK RUN WEST FILING NO. 1, RECORDED AT RECEPTION NUMBER 2020000102832 IN SAID RECORDS;

THENCE ALONG THE WESTERLY BOUNDARY OF SAID WOLF CREEK RUN WEST FILING NO. 1 THE FOLLOWING TWENTY-SIX (26) COURSES:

1. SOUTH 00°37'55" EAST, A DISTANCE OF 381.21 FEET;
2. SOUTH 89°22'05" WEST, A DISTANCE OF 42.78 FEET;
3. SOUTH 00°37'55" EAST, A DISTANCE OF 716.00 FEET;
4. SOUTH 89°22'05" WEST, A DISTANCE OF 135.00 FEET;
5. NORTH 45°37'55" WEST, A DISTANCE OF 21.21 FEET;
6. SOUTH 89°22'05" WEST, A DISTANCE OF 27.00 FEET;
7. SOUTH 00°37'55" EAST, A DISTANCE OF 28.50 FEET;
8. SOUTH 89°22'05" WEST, A DISTANCE OF 177.00 FEET;
9. SOUTH 00°37'55" EAST, A DISTANCE OF 268.65 FEET;
10. NORTH 89°22'05" EAST, A DISTANCE OF 177.00 FEET;
11. SOUTH 00°37'55" EAST, A DISTANCE OF 131.00 FEET;
12. SOUTH 44°22'05" WEST, A DISTANCE OF 21.21 FEET;
13. SOUTH 00°37'55" EAST, A DISTANCE OF 27.00 FEET;
14. NORTH 89°22'05" EAST, A DISTANCE OF 490.50 FEET;
15. SOUTH 45°37'55" EAST, A DISTANCE OF 21.21 FEET;
16. SOUTH 00°37'55" EAST, A DISTANCE OF 270.00 FEET;
17. SOUTH 44°22'05" WEST, A DISTANCE OF 21.21 FEET;
18. SOUTH 00°37'45" EAST, A DISTANCE OF 27.00 FEET;

## ALTA COMMITMENT

### Old Republic National Title Insurance Company

#### Schedule A

Order Number: ABC70779829.1

19. SOUTH 45°37'55" EAST, A DISTANCE OF 21.22 FEET;  
20. SOUTH 00°37'55" EAST, A DISTANCE OF 270.00 FEET;  
21. SOUTH 44°22'05" WEST, A DISTANCE OF 21.21 FEET;  
22. SOUTH 00°37'55" EAST, A DISTANCE OF 27.00 FEET;  
23. SOUTH 45°37'55" EAST, A DISTANCE OF 21.21 FEET;  
24. SOUTH 00°37'55" EAST, A DISTANCE OF 309.60 FEET;  
25. SOUTH 44°22'05" WEST, A DISTANCE OF 28.61 FEET;  
26. SOUTH 00°37'23" EAST, A DISTANCE OF 70.00 FEET TO THE SOUTH LINE OF THE SOUTHEAST QUARTER (SE1/4) OF SAID SECTION 29;

THENCE SOUTH 89°22'32" WEST, ALONG SAID SOUTH LINE, A DISTANCE OF 1,625.44 FEET TO THE SOUTH QUARTER (S1/4) CORNER OF SAID SECTION 29;

THENCE SOUTH 89°22'09" WEST, ALONG THE SOUTH LINE OF THE SOUTHWEST QUARTER (SW1/4) OF SAID SECTION 29, A DISTANCE OF 2,491.44 FEET TO THE EASTERLY RIGHT-OF-WAY LINE OF WOLF CREEK ROAD AS DESCRIBED AND RECORDED IN BOOK 173 AT PAGE [67](#) IN SAID RECORDS;

THENCE ALONG SAID EASTERLY RIGHT-OF-WAY LINE THE FOLLOWING THREE (3) COURSES:

1. NORTH 02°41'48" EAST, A DISTANCE OF 757.29 FEET TO A POINT OF CURVATURE;
2. ALONG THE ARC OF A TANGENT CURVE TO THE LEFT HAVING A CENTRAL ANGLE OF 09°35'41", A RADIUS OF 1,504.00 FEET, AN ARC LENGTH OF 251.86 FEET, THE CHORD OF WHICH BEARS NORTH 02°06'03" WEST, A DISTANCE OF 251.56 FEET;
3. NORTH 06°53'53" WEST, A DISTANCE OF 303.51 FEET TO THE NORTH LINE OF THE SOUTHWEST QUARTER OF THE SOUTHWEST QUARTER (SW1/4SW1/4) OF SAID SECTION 29;

THENCE NORTH 89°12'52" EAST, ALONG SAID NORTH LINE, A DISTANCE OF 1,203.92 FEET TO THE NORTHEAST CORNER OF SAID SOUTHWEST QUARTER OF THE SOUTHWEST QUARTER (SW1/4SW1/4);

THENCE NORTH 00°13'40" WEST, ALONG THE WEST LINE OF SAID NORTHEAST QUARTER OF THE SOUTHWEST QUARTER (NE1/4SW1/4), A DISTANCE OF 809.65 FEET TO THE SOUTHWEST CORNER OF THAT PARCEL OF LAND AS DESCRIBED IN QUITCLAIM DEED RECORDED AT RECEPTION NUMBER C0935218 IN SAID RECORDS;

THENCE ALONG THE SOUTHERLY AND EASTERLY BOUNDARY OF SAID PARCEL THE FOLLOWING THREE (3) COURSES:

1. SOUTH 70°17'39" EAST, A DISTANCE OF 771.28 FEET;
2. NORTH 52°11'47" EAST, A DISTANCE OF 736.37 FEET;
3. NORTH 00°10'45" EAST, A DISTANCE OF 295.30 FEET TO THE POINT OF BEGINNING.

This page is only a part of a 2021 ALTA® Commitment for Title Insurance. This Commitment is not valid without the Notice; the Commitment to Issue Policy; the Commitment Conditions; Schedule A; Schedule B, Part I—Requirements; Schedule B, Part II—Exceptions; and a counter-signature by the Company or its issuing agent that may be in electronic form.

AMERICAN  
LAND TITLE  
ASSOCIATION



Copyright 2021 American Land Title Association. All rights reserved.

**ALTA COMMITMENT**

**Old Republic National Title Insurance Company**

**Schedule A**

**Order Number: ABC70779829.1**

The use of this Form is restricted to ALTA licensees and ALTA members in good standing as of the date of use. All other uses are prohibited. Reprinted under license from the American Land Title Association.

**ALTA COMMITMENT**

**Old Republic National Title Insurance Company**

**Schedule B, Part I**

**(Requirements)**

**Order Number:** ABC70779829.1

**All of the following Requirements must be met:**

**This proposed Insured must notify the Company in writing of the name of any party not referred to in this Commitment who will obtain an interest in the Land or who will make a loan on the Land. The Company may then make additional Requirements or Exceptions.**

**Pay the agreed amount for the estate or interest to be insured.**

**Pay the premiums, fees, and charges for the Policy to the Company.**

**Documents satisfactory to the Company that convey the Title or create the Mortgage to be insured, or both, must be properly authorized, executed, delivered, and recorded in the Public Records.**

THIS COMMITMENT IS FOR INFORMATION ONLY, AND NO POLICY WILL BE ISSUED PURSUANT HERETO.

NOTE: THIS COMMITMENT IS NOT A REPORT OR REPRESENTATION AS TO MINERAL INTERESTS, AND SHOULD NOT BE USED, OR RELIED UPON, IN CONNECTION WITH THE NOTICE REQUIREMENTS THAT ARE SET FORTH IN CRS 24-65.5-103.

NOTE: THE COMMITMENT DOES NOT REFLECT THE STATUS OF TITLE TO WATER RIGHTS OR REPRESENTATION OF SAID RIGHTS.

**ALTA COMMITMENT**  
**Old Republic National Title Insurance Company**  
**Schedule B, Part II**  
**(Exceptions)**

Order Number: ABC70779829.1

Some historical land records contain Discriminatory Covenants that are illegal and unenforceable by law. This Commitment and the Policy treat any Discriminatory Covenant in a document referenced in Schedule B as if each Discriminatory Covenant is redacted, repudiated, removed, and not republished or recirculated. Only the remaining provisions of the document will be excepted from coverage.

1. Any facts, rights, interests, or claims thereof, not shown by the Public Records but that could be ascertained by an inspection of the Land or that may be asserted by persons in possession of the Land.
2. Easements, liens or encumbrances, or claims thereof, not shown by the Public Records.
3. Any encroachment, encumbrance, violation, variation, or adverse circumstance affecting the Title that would be disclosed by an accurate and complete land survey of the Land and not shown by the Public Records.
4. Any lien, or right to a lien, for services, labor or material heretofore or hereafter furnished, imposed by law and not shown by the Public Records.
5. Defects, liens, encumbrances, adverse claims or other matters, if any, created, first appearing in the public records or attaching subsequent to the effective date hereof but prior to the date of the proposed insured acquires of record for value the estate or interest or mortgage thereon covered by this Commitment.
6. (a) Taxes or assessments that are not shown as existing liens by the records of any taxing authority that levies taxes or assessments on real property or by the Public Records; (b) proceedings by a public agency that may result in taxes or assessments, or notices of such proceedings, whether or not shown by the records of such agency or by the Public Records.
7. (a) Unpatented mining claims; (b) reservations or exceptions in patents or in Acts authorizing the issuance thereof; (c) water rights, claims or title to water.
8. EXISTING LEASES AND TENANCIES, IF ANY.
9. RESERVATIONS BY THE UNION PACIFIC LAND COMPANY COMPANY OF:  
(1) ALL OIL, COAL AND OTHER MINERALS UNDERLYING SUBJECT PROPERTY,  
(2) THE EXCLUSIVE RIGHT TO PROSPECT FOR, MINE AND REMOVE OIL, COAL AND OTHER MINERALS, AND  
(3) THE RIGHT OF INGRESS AND EGRESS AND REGRESS TO PROSPECT FOR, MINE AND REMOVE OIL, COAL AND OTHER MINERALS, ALL AS CONTAINED IN DEED RECORDED JULY 19, 1906, IN BOOK 25 AT PAGE [157](#).  
  
RELEASE AND QUITCLAIM DEED RECORDED NOVEMBER 23, 1998 UNDER RECEPTION NO. [C0470914](#).  
  
QUITCLAIM AND RELINQUISHMENT RECORDED JANUARY 20, 2023 UNDER RECEPTION NO. [2023000003847](#).
10. LEASE BETWEEN CHAMPLIN PETROLEUM COMPANY, LESSOR, AND AMOCO PRODUCTION COMPANY, LESSEE, AS SHOWN BY MEMORANDUM OF LEASE RECORDED AUGUST 12, 1976, IN BOOK 2082 AT PAGE [672](#).  
AFFIDAVIT OF PRODUCTION IN CONNECTION WITH SAID OIL AND GAS LEASE RECORDED MARCH 9, 1983 IN BOOK 2724 AT PAGE [861](#).
11. TERMS, CONDITIONS, PROVISIONS, BURDENS AND OBLIGATIONS AS SET FORTH IN SURFACE OWNER'S AGREEMENT RECORDED FEBRUARY 26, 1987 IN BOOK 3278 AT PAGE [853](#).

**ALTA COMMITMENT**  
**Old Republic National Title Insurance Company**  
**Schedule B, Part II**  
**(Exceptions)**

**Order Number:** ABC70779829.1

12. TERMS, CONDITIONS, PROVISIONS, BURDENS AND OBLIGATIONS AS SET FORTH IN RESOLUTION ESTABLISHING TAP FEES AND USER FEES RECORDED OCTOBER 18, 2001 UNDER RECEPTION NO. [C0874738](#).
13. TERMS, CONDITIONS, PROVISIONS, BURDENS AND OBLIGATIONS AS SET FORTH IN AGREEMENT BY AND BETWEEN STRASBURG SCHOOL DISTRICT NO. 31-J AND PAULS DEVELOPMENT EAST LLC RECORDED MARCH 14, 2002 UNDER RECEPTION NO. [C0940261](#). FIRST AMENDMENT RECORDED JUNE 8, 2015 UNDER RECEPTION NO. [2015000043393](#). SECOND AMENDMENT TO SCHOOL AGREEMENT RECORDED JANUARY 6, 2021 UNDER RECEPTION NO. [2021000001698](#).
14. TERMS, CONDITIONS, PROVISIONS, BURDENS, OBLIGATIONS AND EASEMENTS AS SET FORTH AND GRANTED IN EASEMENT AGREEMENT BY AND BETWEEN PAULS DEVELOPMENT EAST, LLC AND EASTERN ADAMS COUNTY METROPOLITAN DISTRICT RECORDED APRIL 22, 2002 UNDER RECEPTION NO. [C0958528](#).
15. REQUEST FOR NOTIFICATION OF SURFACE DEVELOPMENT AS EVIDENCED BY INSTRUMENT RECORDED MAY 20, 2002 UNDER RECEPTION NO. [C0971869](#).
16. OIL AND GAS LEASE BETWEEN RME PETROLEUM COMPANY AND UNITED STATES EXPLORATION, INC., RECORDED MAY 20, 2002 UNDER RECEPTION NO. [C0971940](#) AND ANY AND ALL ASSIGNMENTS THEREOF, OR INTEREST THEREIN.
17. TERMS, CONDITIONS, PROVISIONS, BURDENS AND OBLIGATIONS AS SET FORTH IN STRASBURG PARK & RECREATION DISTRICT AND PAULS DEVELOPMENT EAST, LLC RECORDED JUNE 10, 2002 UNDER RECEPTION NO. [C0981594](#) AND RE-RECORDED JULY 25, 2002 UNDER RECEPTION NO. [C1001612](#).
18. TERMS, CONDITIONS, PROVISIONS, BURDENS AND OBLIGATIONS AS SET FORTH IN ZONING HEARING DECISION - CASE PUD2001-00031 WOLF CREEK RUN PUD RECORDED JUNE 11, 2002 UNDER RECEPTION NO. [C0982152](#).
19. TERMS, CONDITIONS, PROVISIONS, BURDENS AND OBLIGATIONS AS SET FORTH IN COLORADO GROUND WATER COMMISSION FINDINGS AND ORDERS RECORDED AUGUST 23, 2002 UNDER RECEPTION NO. [C1014314](#), [C1014315](#), AUGUST 26, 2002 UNDER RECEPTION NO. [C1014767](#), JANUARY 25, 2005 UNDER RECEPTION NO. [20050125000081300](#), [20050125000081310](#), [20050125000081340](#), [20050125000081350](#), [20050125000081360](#), [20050125000081370](#), MARCH 11, 2005 UNDER RECEPTION NO. [20050311000252850](#), [20050311000252860](#), [20050311000252870](#), AND DECEMBER 9, 2021 UNDER RECEPTION NO. [2021000143981](#).
20. EASEMENTS, CONDITIONS, COVENANTS, RESTRICTIONS, RESERVATIONS AND NOTES ON THE WOLF CREEK RUN PRELIMINARY P.U.D PLAN RECORDED SEPTEMBER 20, 2002 UNDER RECEPTION NO. [C1026448](#).  
  
FIRST AMENDMENT RECORDED SEPTEMBER 2, 2003 UNDER RECEPTION NO. [C1202246](#).
21. TERMS, CONDITIONS, PROVISIONS, BURDENS AND OBLIGATIONS AS SET FORTH IN AGREEMENT BY AND BETWEEN STRASBURG FIRE PROTECTION DISTRICT NO. 8 AND PAULS DEVELOPMENT EAST, LLC, AND RESOLUTION IMPOSING DEVELOPMENT FEES RECORDED DECEMBER 11, 2002 UNDER RECEPTION NO. [C1065640](#).  
  
FIRST AMENDMENT TO AGREEMENT RECORDED JULY 29, 2015 UNDER RECEPTION NO. [2015000061698](#)

**ALTA COMMITMENT**  
**Old Republic National Title Insurance Company**  
**Schedule B, Part II**  
**(Exceptions)**

**Order Number:** ABC70779829.1

22. TERMS, CONDITIONS, PROVISIONS, BURDENS AND OBLIGATIONS AS SET FORTH IN ZONING HEARING DECISION - CASE #PRJ2003-00021 WOLF CREEK RUN PUD RECORDED AUGUST 07, 2003 UNDER RECEPTION NO. [C1189492](#).
23. TERMS, CONDITIONS, PROVISIONS, BURDENS AND OBLIGATIONS AS SET FORTH IN CONNECTOR'S AGREEMENT BY AND BETWEEN EASTERN ADAMS COUNTY METROPOLITAN DISTRICT AND PAULS DEVELOPMENT EAST, LLC, RECORDED DECEMBER 05, 2003 UNDER RECEPTION NO. [C1248735](#).
24. EASEMENT GRANTED TO INTERMOUNTAIN RURAL ELECTRIC ASSOCIATION, FOR ELECTRIC SERVICE LINES, DISTRIBUTION SYSTEMS, AND INCIDENTAL PURPOSES, BY INSTRUMENT RECORDED JULY 16, 2004, UNDER RECEPTION NO. [20040716000624660](#).
25. TERMS, CONDITIONS, PROVISIONS, BURDENS AND OBLIGATIONS AS SET FORTH IN ZONING HEARING DECISION - CASE #PLT2005-00046 WOLF CREEK RUN WEST RECORDED MARCH 13, 2006 UNDER RECEPTION NO. [20060313000254620](#).
26. TERMS, CONDITIONS, PROVISIONS, BURDENS AND OBLIGATIONS AS SET FORTH IN SURFACE USE AGREEMENT RECORDED SEPTEMBER 29, 2006 UNDER RECEPTION NO. [20060929000981180](#).  
  
NOTICES OF RIGHT TO USE SURFACE OF LAND RECORDED MARCH 11, 2013 UNDER RECEPTION NOS. [2013000020841](#) AND [2013000020842](#).  
  
AMENDMENT TO SURFACE USE AGREEMENT RECORDED AUGUST 8, 2019 UNDER RECEPTION NO. [2019000063940](#).  
  
TERMINATION OF AGREEMENTS AND RELEASE OF MEMORANDUM OF AGREEMENT RECORDED JANUARY 20, 2023 UNDER RECEPTION NO. [2023000003846](#).  
  
SECOND AMENDMENT TO SURFACE USE AGREEMENT RECORDED JANUARY 20, 2023 UNDER RECEPTION NO. [2023000003849](#).  
  
NOTE: THE ELECTRICAL EASEMENT REFERENCED IN SECTION 11 OF AMENDMENT TO SURFACE USE AGREEMENT WAS TERMINATED AND REPLACED/RELOCATED BY SECOND AMENDMENT TO SURFACE USE AGREEMENT, AND POWER LINE EASEMENT REFERENCED IN EXCEPTION 44.
27. TERMS, CONDITIONS, PROVISIONS, BURDENS, OBLIGATIONS AND EASEMENTS AS SET FORTH AND GRANTED IN DECLARATION OF EASEMENT RECORDED SEPTEMBER 07, 2007 UNDER RECEPTION NO. [2007000085508](#).
28. TERMS, CONDITIONS, PROVISIONS, BURDENS AND OBLIGATIONS AS SET FORTH IN RESOLUTION APPROVING A THREE-YEAR EXTENSION IN CASE #PLN2017-00020 WOLF CREEK RUN RECORDED MARCH 21, 2019 UNDER RECEPTION NO. [2019000020597](#).
29. TERMS, CONDITIONS, PROVISIONS, BURDENS AND OBLIGATIONS AS SET FORTH IN RESOLUTION APPROVING A THREE-YEAR EXTENSION IN CASE #PLN2017-00020 WOLF CREEK RUN RECORDED MARCH 21, 2019 UNDER RECEPTION NO. [2019000022106](#).
30. TERMS, CONDITIONS, PROVISIONS, BURDENS AND OBLIGATIONS AS SET FORTH IN RESOLUTION APPROVING APPLICATION IN CASE #PLT2018-00008 WOLF CREEK RUN WEST, FILING 1 RECORDED MAY 06, 2019 UNDER RECEPTION NO. [2019000033803](#).



**ALTA COMMITMENT**  
**Old Republic National Title Insurance Company**  
**Schedule B, Part II**  
**(Exceptions)**

**Order Number:** ABC70779829.1

31. TERMS, CONDITIONS, PROVISIONS, BURDENS AND OBLIGATIONS AS SET FORTH IN WOLF CREEK RUN WEST FINAL DEVELOPMENT PLAN RECORDED OCTOBER 08, 2020 UNDER RECEPTION NO. [2020000102831](#), AND AMENDMENT 1 RECORDED SEPTEMBER 10, 2021 UNDER RECEPTION NO. [2021000107609](#).
32. TERMS, CONDITIONS, PROVISIONS, BURDENS AND OBLIGATIONS AS SET FORTH IN RESOLUTION APPROVING APPLICATION IN CASE #PRC2019-00009 WOLF CREEK RUN WEST, AND SUBDIVISION IMPROVEMENTS AGREEMENT RECORDED OCTOBER 14, 2020 UNDER RECEPTION NOS. [2020000103827](#) AND [2020000103886](#).
33. CONVEYANCE OF WATER RIGHTS AS SET FORTH IN WATER RIGHTS DEED RECORDED APRIL 30, 2021 UNDER RECEPTION NO. [2021000053239](#).
34. TERMS, CONDITIONS, PROVISIONS, BURDENS, OBLIGATIONS AND EASEMENTS AS SET FORTH AND GRANTED IN DECLARATION OF EASEMENT RECORDED AUGUST 20, 2021 UNDER RECEPTION NO. [2021000099881](#). FIRST AMENDMENT TO DECLARATION OF EASEMENT RECORDED NOVEMBER 18, 2022 UNDER RECEPTION NO. [2022000092100](#).
35. TERMS, CONDITIONS AND PROVISIONS OF FINDINGS AND ORDER RECORDED AUGUST 26, 2021 UNDER RECEPTION NO. [2021000102176](#) AND RECORDED AUGUST 26, 2021 UNDER RECEPTION NO. [2021000102177](#).
36. TERMS, CONDITIONS, PROVISIONS, BURDENS AND OBLIGATIONS AS SET FORTH IN RESOLUTION RECORDED SEPTEMBER 28, 2021 UNDER RECEPTION NO. [2021000113960](#).
37. TERMS, CONDITIONS, PROVISIONS, BURDENS AND OBLIGATIONS AS SET FORTH IN RESOLUTION RECORDED SEPTEMBER 30, 2021 UNDER RECEPTION NO. [2021000116370](#).
38. TERMS, CONDITIONS, PROVISIONS, BURDENS, OBLIGATIONS AND EASEMENTS AS SET FORTH AND GRANTED IN DECLARATION OF EASEMENT RECORDED NOVEMBER 19, 2021 UNDER RECEPTION NO. [2021000136125](#).
39. TERMS, CONDITIONS, PROVISIONS, BURDENS, OBLIGATIONS AND EASEMENTS AS SET FORTH AND GRANTED IN POWER LINE EASEMENT RECORDED JANUARY 20, 2023 UNDER RECEPTION NO. [2023000003848](#).
40. DEED OF TRUST DATED JANUARY 31, 2024 FROM WOLF CREEK RUN WEST LLC, A COLORADO LIMITED LIABILITY COMPANY TO THE PUBLIC TRUSTEE OF ADAMS COUNTY FOR THE USE OF PAULS DEVELOPMENT EAST, LLC, A COLORADO LIMITED LIABILITY COMPANY TO SECURE THE SUM OF \$2,000,000.00, AND ANY OTHER AMOUNTS PAYABLE UNDER THE TERMS THEREOF, RECORDED JANUARY 31, 2024, UNDER RECEPTION NO. [2024000005095](#).



# ALTA Commitment For Title Insurance

## issued by Old Republic National Title Insurance Company

### NOTICE

IMPORTANT—READ CAREFULLY: THIS COMMITMENT IS AN OFFER TO ISSUE ONE OR MORE TITLE INSURANCE POLICIES. ALL CLAIMS OR REMEDIES SOUGHT AGAINST THE COMPANY INVOLVING THE CONTENT OF THIS COMMITMENT OR THE POLICY MUST BE BASED SOLELY IN CONTRACT.

THIS COMMITMENT IS NOT AN ABSTRACT OF TITLE, REPORT OF THE CONDITION OF TITLE, LEGAL OPINION, OPINION OF TITLE, OR OTHER REPRESENTATION OF THE STATUS OF TITLE. THE PROCEDURES USED BY THE COMPANY TO DETERMINE INSURABILITY OF THE TITLE, INCLUDING ANY SEARCH AND EXAMINATION, ARE PROPRIETARY TO THE COMPANY, WERE PERFORMED SOLELY FOR THE BENEFIT OF THE COMPANY, AND CREATE NO EXTRACONTRACTUAL LIABILITY TO ANY PERSON, INCLUDING A PROPOSED INSURED.

THE COMPANY'S OBLIGATION UNDER THIS COMMITMENT IS TO ISSUE A POLICY TO A PROPOSED INSURED IDENTIFIED IN SCHEDULE A IN ACCORDANCE WITH THE TERMS AND PROVISIONS OF THIS COMMITMENT. THE COMPANY HAS NO LIABILITY OR OBLIGATION INVOLVING THE CONTENT OF THIS COMMITMENT TO ANY OTHER PERSON. .

### COMMITMENT TO ISSUE POLICY

Subject to the Notice; Schedule B, Part I—Requirements; Schedule B, Part II—Exceptions; and the Commitment Conditions, Old Republic National Title Insurance Company, a Minnesota corporation (the "Company"), commits to issue the Policy according to the terms and provisions of this Commitment. This Commitment is effective as of the Commitment Date shown in Schedule A for each Policy described in Schedule A, only when the Company has entered in Schedule A both the specified dollar amount as the Proposed Amount of insurance and the name of the Proposed Insured. If all of the Schedule B, Part I—Requirements have not been met within 6 months after the Commitment Date, this Commitment terminates and the Company's liability and obligation end.

### COMMITMENT CONDITIONS

#### 1. DEFINITIONS

- (a) "Discriminatory Covenant": Any covenant, condition, restriction, or limitation that is unenforceable under applicable law because it illegally discriminates against a class of individuals based on personal characteristics such as race, color, religion, sex, sexual orientation, gender identity, familial status, disability, national origin, or other legally protected class.
- (b) "Knowledge" or "Known": Actual knowledge or actual notice, but not constructive notice imparted by the Public Records.
- (c) "Land": The land described in item 5 of Schedule A and affixed improvements located on that land that by State law constitute real property. The term "Land" does not include any property beyond that described in Schedule A, nor any right, title, interest, estate, or easement in any abutting street, road, avenue, alley, lane, right-of-way, body of water, or waterway, but does not modify or limit the extent that a right of access to and from the Land is to be insured by the Policy.
- (d) "Mortgage": A mortgage, deed of trust, trust deed, security deed, or other real property security instrument, including one evidenced by electronic means authorized by law.
- (e) "Policy": Each contract of title insurance, in a form adopted by the American Land Title Association, issued or to be issued by the Company pursuant to this Commitment.
- (f) "Proposed Amount of Insurance": Each dollar amount specified in Schedule A as the Proposed Amount of Insurance of each Policy to be issued pursuant to this Commitment.
- (g) "Proposed Insured": Each person identified in Schedule A as the Proposed Insured of each Policy to be issued pursuant to this Commitment.
- (h) "Public Records": The recording or filing system established under State statutes in effect at the Commitment Date under which a document must be recorded or filed to impart constructive notice of matters relating to the Title to a purchaser for value without Knowledge. The term "Public Records" does not include any other recording or filing system, including any pertaining to environmental remediation or protection, planning, permitting, zoning, licensing, building, health, public safety, or national security matters.
- (i) "State": The state or commonwealth of the United States within whose exterior boundaries the Land is located. The term "State" also includes the District of Columbia, the Commonwealth of Puerto Rico, the U.S. Virgin Islands, and Guam.
- (j) "Title": The estate or interest in the Land identified in Item 3 of Schedule A.

2. If all of the Schedule B, Part I—Requirements have not been met within the time period specified in the Commitment to Issue Policy, Commitment terminates and the Company's liability and obligation end.

3. The Company's liability and obligation is limited by and this Commitment is not valid without:

- (a) the Notice;
- (b) the Commitment to Issue Policy;
- (c) the Commitment Conditions;
- (d) Schedule A;
- (e) Schedule B, Part I—Requirements; and
- (f) Schedule B, Part II—Exceptions; and
- (g) a counter-signature by the Company or its issuing agent that may be in electronic form.

#### 4. COMPANY'S RIGHT TO AMEND

The Company may amend this Commitment at any time. If the Company amends this Commitment to add a defect, lien, encumbrance, adverse claim, or other matter recorded in the Public Records prior to the Commitment Date, any liability of the Company is limited by Commitment Condition 5. The Company is not liable for any other amendment to this Commitment.

#### 5. LIMITATIONS OF LIABILITY

- (a) The Company's liability under Commitment Condition 4 is limited to the Proposed Insured's actual expense incurred in the interval between the Company's delivery to the Proposed Insured of the Commitment and the delivery of the amended Commitment, resulting from the Proposed Insured's good faith reliance to:
  - i. comply with the Schedule B, Part I—Requirements;
  - ii. eliminate, with the Company's written consent, any Schedule B, Part II—Exceptions; or
  - iii. acquire the Title or create the Mortgage covered by this Commitment.
- (b) The Company is not liable under Commitment Condition 5(a) if the Proposed Insured requested the amendment or had Knowledge of the matter and did not notify the Company about it in writing.
- (c) The Company is only liable under Commitment Condition 4 if the Proposed Insured would not have incurred the expense had the Commitment included the added matter when the Commitment was first delivered to the Proposed Insured.
- (d) The Company's liability does not exceed the lesser of the Proposed Insured's actual expense incurred in good faith and described in Commitment Condition 5(a) or the Proposed Amount of Insurance.
- (e) The Company is not liable for the content of the Transaction Identification Data, if any.
- (f) The Company is not obligated to issue the Policy referred to in this Commitment unless all of the Schedule B, Part I—Requirements have been met to the satisfaction of the Company.

(g) The Company's liability is further limited by the terms and provisions of the Policy to be issued to the Proposed Insured.

**6. LIABILITY OF THE COMPANY MUST BE BASED ON THIS COMMITMENT. CHOICE OF LAW AND CHOICE OF FORUM**

- (a) Only a Proposed Insured identified in Schedule A, and no other person, may make a claim under this Commitment.
- (b) Any claim must be based in contract under the State law of the State where the Land is located and is restricted to the terms and provisions of this Commitment. Any litigation or other proceeding brought by the Proposed Insured against the Company must be filed only in a State or federal court having jurisdiction
- (c) This Commitment, as last revised, is the exclusive and entire agreement between the parties with respect to the subject matter of this Commitment and supersedes all prior commitment negotiations, representations, and proposals of any kind, whether written or oral, express or implied, relating to the subject matter of this Commitment.
- (d) The deletion or modification of any Schedule B, Part II—Exception does not constitute an agreement or obligation to provide coverage beyond the terms and provisions of this Commitment or the Policy.
- (e) Any amendment or endorsement to this Commitment must be in writing and authenticated by a person authorized by the Company.
- (f) When the Policy is issued, all liability and obligation under this Commitment will end and the Company's only liability will be under the Policy.

**7. IF THIS COMMITMENT IS ISSUED BY AN ISSUING AGENT**

The issuing agent is the Company's agent only for the limited purpose of issuing title insurance commitments and policies. The issuing agent is not the Company's agent for the purpose of providing closing or settlement services.

**8. PRO-FORMA POLICY**

The Company may provide, at the request of a Proposed Insured, a pro-forma policy illustrating the coverage that the Company may provide. A pro-forma policy neither reflects the status of Title at the time that the pro-forma policy is delivered to a Proposed Insured, nor is it a commitment to insure.

**9. CLAIMS PROCEDURES**

This Commitment incorporates by reference all Conditions for making a claim in the Policy to be issued to the Proposed Insured. Commitment Condition 9 does not modify the limitations of liability in Commitment Conditions 5 and 6.

**10. CLASS ACTION**

ALL CLAIMS AND DISPUTES ARISING OUT OF OR RELATING TO THIS COMMITMENT, INCLUDING ANY SERVICE OR OTHER MATTER IN CONNECTION WITH ISSUING THIS COMMITMENT, ANY BREACH OF A COMMITMENT PROVISION, OR ANY OTHER CLAIM OR DISPUTE ARISING OUT OF OR RELATING TO THE TRANSACTION GIVING RISE TO THIS COMMITMENT, MUST BE BROUGHT IN AN INDIVIDUAL CAPACITY. NO PARTY MAY SERVE AS PLAINTIFF, CLASS MEMBER, OR PARTICIPANT IN ANY CLASS OR REPRESENTATIVE PROCEEDING. ANY POLICY ISSUED PURSUANT TO THIS COMMITMENT WILL CONTAIN A CLASS ACTION CONDITION.

**11. ARBITRATION**

The Policy contains an arbitration clause. All arbitrable matters when the Proposed Amount of insurance is \$2,000,000 or less may be arbitrated at the election of either the Company or the Proposed Insured as the exclusive remedy of the parties. A Proposed Insured may review a copy of the arbitration rules at <http://www.alta.org/arbitration>

IN WITNESS WHEREOF, Old Republic National Title Insurance Company has caused its corporate name and seal to be affixed by its duly authorized officers on the date shown in Schedule A to be valid when countersigned by a validating officer or other authorized signatory.

Issued by:  
Land Title Guarantee Company  
3033 East First Avenue Suite 600  
Denver, Colorado 80206  
303-321-1880



Craig B. Rants, Senior Vice President



**OLD REPUBLIC NATIONAL TITLE INSURANCE COMPANY**  
A Stock Company  
400 Second Avenue South, Minneapolis, Minnesota 55401  
(612) 371-1111

By  President

Attest  Secretary

This page is only a part of a 2021 ALTA® Commitment for Title Insurance issued by Old Republic National Title Insurance Company. This Commitment is not valid without the Notice; the Commitment to Issue Policy; the Commitment Conditions; Schedule A; Schedule B, Part I—Requirements; and Schedule B, Part II—Exceptions; and a counter-signature by the Company or its issuing agent that may be in electronic form.

Copyright 2021 American Land Title Association. All rights reserved.

The use of this Form (or any derivative thereof) is restricted to ALTA licensees and ALTA members in good standing as of the date of use. All other uses are prohibited. Reprinted under license from the American Land Title Association.



## Land Title Guarantee Company Disclosure Statements

**Note: Pursuant to CRS 10-11-122, notice is hereby given that:**

- (A) The Subject real property may be located in a special taxing district.
- (B) A certificate of taxes due listing each taxing jurisdiction will be obtained from the county treasurer of the county in which the real property is located or that county treasurer's authorized agent unless the proposed insured provides written instructions to the contrary. (for an Owner's Policy of Title Insurance pertaining to a sale of residential real property).
- (C) The information regarding special districts and the boundaries of such districts may be obtained from the Board of County Commissioners, the County Clerk and Recorder, or the County Assessor.

**Note:** Effective September 1, 1997, CRS 30-10-406 requires that all documents received for recording or filing in the clerk and recorder's office shall contain a top margin of at least one inch and a left, right and bottom margin of at least one half of an inch. The clerk and recorder may refuse to record or file any document that does not conform, except that, the requirement for the top margin shall not apply to documents using forms on which space is provided for recording or filing information at the top margin of the document.

**Note:** Colorado Division of Insurance Regulations 8-1-2 requires that "Every title entity shall be responsible for all matters which appear of record prior to the time of recording whenever the title entity conducts the closing and is responsible for recording or filing of legal documents resulting from the transaction which was closed". Provided that Land Title Guarantee Company conducts the closing of the insured transaction and is responsible for recording the legal documents from the transaction, exception number 5 will not appear on the Owner's Title Policy and the Lenders Policy when issued.

**Note:** Affirmative mechanic's lien protection for the Owner may be available (typically by deletion of Exception no. 4 of Schedule B, Section 2 of the Commitment from the Owner's Policy to be issued) upon compliance with the following conditions:

- (A) The land described in Schedule A of this commitment must be a single family residence which includes a condominium or townhouse unit.
- (B) No labor or materials have been furnished by mechanics or material-men for purposes of construction on the land described in Schedule A of this Commitment within the past 6 months.
- (C) The Company must receive an appropriate affidavit indemnifying the Company against un-filed mechanic's and material-men's liens.
- (D) The Company must receive payment of the appropriate premium.
- (E) If there has been construction, improvements or major repairs undertaken on the property to be purchased within six months prior to the Date of Commitment, the requirements to obtain coverage for unrecorded liens will include: disclosure of certain construction information; financial information as to the seller, the builder and or the contractor; payment of the appropriate premium fully executed Indemnity Agreements satisfactory to the company, and, any additional requirements as may be necessary after an examination of the aforesaid information by the Company.

No coverage will be given under any circumstances for labor or material for which the insured has contracted for or agreed to pay.

**Note:** Pursuant to CRS 10-11-123, notice is hereby given:

This notice applies to owner's policy commitments disclosing that a mineral estate has been severed from the surface estate, in Schedule B-2.

- (A) That there is recorded evidence that a mineral estate has been severed, leased, or otherwise conveyed from the surface estate and that there is substantial likelihood that a third party holds some or all interest in oil, gas, other minerals, or geothermal energy in the property; and
- (B) That such mineral estate may include the right to enter and use the property without the surface owner's permission.

**Note:** Pursuant to CRS 10-1-128(6)(a), It is unlawful to knowingly provide false, incomplete, or misleading facts or information to an insurance company for the purpose of defrauding or attempting to defraud the company. Penalties may include imprisonment, fines, denial of insurance, and civil damages. Any insurance company or agent of an insurance company who knowingly provides false, incomplete, or misleading facts or information to a policyholder or claimant for the purpose of defrauding or attempting to defraud the policyholder or claimant with regard to a settlement or award payable from insurance proceeds shall be reported to the Colorado Division of Insurance within the Department of Regulatory Agencies.

**Note:** Pursuant to Colorado Division of Insurance Regulations 8-1-3, notice is hereby given of the availability of a closing protection letter for the lender, purchaser, lessee or seller in connection with this transaction.

**Note:** Pursuant to CRS 24-21-514.5, Colorado notaries may remotely notarize real estate deeds and other documents using real-time audio-video communication technology. You may choose not to use remote notarization for any document.



## **Joint Notice of Privacy Policy of Land Title Guarantee Company Land Title Insurance Corporation and Old Republic National Title Insurance Company**

This Statement is provided to you as a customer of Land Title Guarantee Company as agent for Land Title Insurance Corporation and Old Republic National Title Insurance Company.

We want you to know that we recognize and respect your privacy expectations and the requirements of federal and state privacy laws. Information security is one of our highest priorities. We recognize that maintaining your trust and confidence is the bedrock of our business. We maintain and regularly review internal and external safeguards against unauthorized access to your non-public personal information ("Personal Information").

In the course of our business, we may collect Personal Information about you from:

- applications or other forms we receive from you, including communications sent through TMX, our web-based transaction management system;
  - your transactions with, or from the services being performed by us, our affiliates, or others;
  - a consumer reporting agency, if such information is provided to us in connection with your transaction;
- and
- The public records maintained by governmental entities that we obtain either directly from those entities, or from our affiliates and non-affiliates.

Our policies regarding the protection of the confidentiality and security of your Personal Information are as follows:

- We restrict access to all Personal Information about you to those employees who need to know that information in order to provide products and services to you.
- We may share your Personal Information with affiliated contractors or service providers who provide services in the course of our business, but only to the extent necessary for these providers to perform their services and to provide these services to you as may be required by your transaction.
- We maintain physical, electronic and procedural safeguards that comply with federal standards to protect your Personal Information from unauthorized access or intrusion.
- Employees who violate our strict policies and procedures regarding privacy are subject to disciplinary action.
- We regularly assess security standards and procedures to protect against unauthorized access to Personal Information.

**WE DO NOT DISCLOSE ANY PERSONAL INFORMATION ABOUT YOU WITH ANYONE FOR ANY PURPOSE THAT IS NOT STATED ABOVE OR PERMITTED BY LAW.**

Consistent with applicable privacy laws, there are some situations in which Personal Information may be disclosed. We may disclose your Personal Information when you direct or give us permission; when we are required by law to do so, for example, if we are served a subpoena; or when we suspect fraudulent or criminal activities. We also may disclose your Personal Information when otherwise permitted by applicable privacy laws such as, for example, when disclosure is needed to enforce our rights arising out of any agreement, transaction or relationship with you.

Our policy regarding dispute resolution is as follows: Any controversy or claim arising out of or relating to our privacy policy, or the breach thereof, shall be settled by arbitration in accordance with the rules of the American Arbitration

Association, and judgment upon the award rendered by the arbitrator(s) may be entered in any court having jurisdiction thereof.

## CONNECTOR'S AGREEMENT

THIS CONNECTORS AGREEMENT ("Agreement") is made as of the 17<sup>th</sup> day of February, 2021, by and between **EASTERN ADAMS COUNTY METROPOLITAN DISTRICT** a quasi-municipal corporation and political subdivision of the State of Colorado ("the District") and **FORESTAR (USA) REAL ESTATE GROUP INC.**, a Delaware corporation and its successors and assigns (the "Applicant"). The parties are sometimes referred to herein as a "Party" or the "Parties."

### RECITALS

WHEREAS, the District is currently providing services to certain properties within Adams County, Colorado; and

WHEREAS, Applicant is the owner of other real properties in Adams County, a legal description of which is attached hereto as Exhibit A, and incorporated herein by this reference (the "Initial Property") and Applicant is under contract with PAULS DEVELOPMENT EAST, LLC, a Colorado limited liability company (the "Developer") to purchase additional property in Adams County, a legal description of which is attached hereto as Exhibit B (the "Additional Property" and together with the "Initial Property" the "Property"); and

WHEREAS, Applicant recognizes that District provision of potable water supply and sanitary sewer collection, treatment and disposal services, and limited trail and landscape construction and maintenance ("Services") benefit the Property; and

WHEREAS, Applicant hereby agrees to be bound by the policies, rules, regulations, terms and conditions imposed by the District in order to obtain needed Services and/or Additional Services (defined below) and to pay such assessments, fees, charges and tolls associated therewith; and

WHEREAS, the statutes of the State of Colorado permit the District and Applicant to enter into this Agreement for the provision of Services to the Property, and said statutes further provide that such Agreement is binding upon the District and Applicant, and their successors, transferees and assigns; and

NOW THEREFORE, in consideration of the mutual covenants and stipulations herein expressed, District and Applicant agree as follows:

### I. PRELIMINARY COVENANTS.

#### 1. Generally.

A. This Agreement is intended to outline the terms and conditions under which the District will provide Services to the Property, as it lies. In all cases District and Applicant agree that, except as expressly set forth in this Agreement, there shall be no differentiation in the availability, extent, quality, use, or cost of service between the Property and properties within or without the District's boundaries receiving services from the District. The District acknowledges



and agrees that the uses permitted by right or special review under the existing zoning for the Property established by the County, as well as residential use, are provided for within the District's Rules and Regulations, and are eligible for the Services in accordance with the terms of this Agreement.

B. Applicant acknowledges and agrees that the Services provided hereunder include potable water supply and sanitary sewer collection, treatment and disposal services. To the extent Applicant desires, Applicant shall be responsible for the construction and provision of all other services, facilities and related improvements for the Property which are not within the scope of this Agreement, and in the absence of its specific agreement set forth in writing, the District shall have no obligation to contribute to any such effort outside the scope of this Agreement.

2. Timing and Fees. Applicant and District have negotiated this Agreement in good faith in the interest of providing Services to the Property and thereby enhancing the value thereof. In consideration thereof, Applicant hereby agrees to follow all statutory requirements applicable to the Applicant's obligations hereunder, to pay all of their own legal, engineering, or other fees paid or costs incurred, with respect to or arising out of the proceedings and negotiations culminating in the execution of this Agreement, and to reimburse the District for its legal, engineering or other fees paid or costs incurred with respect to or arising out of said proceedings and negotiations and shall upon execution hereof deposit with the District \$15,000 as a fund from which the District will draw to pay these expenses. In order to reimburse the District for all other costs incurred by the District with respect to the execution of this Agreement including, but not limited to, the cost of technical reports detailing the impact of the proposed provision of Services in question on the District's service capacity, and recognizing that said provision of Services to the Property may require that the District expand the capacity of its service systems now or in the future, Applicant, its successors, purchasers and/or permitted assigns shall be required to pay to the District the following: (i) as a condition to the connection of and initiation of water and sewer service to any particular building improvement or separate irrigation facility ("Tap"), a District tap fee in the amount of \$19,500.00 ("Tap Fee"), of which \$10,000.00 will be retained by the District for ongoing needs, with the remaining \$9,500 (the "Applicant Tap Fee") will be rebated to the Applicant, its successors and assigns, as described below, and (ii) a District meter fee in the amount of \$445.50, which shall be paid upon application for a building permit for each lot.

3. Replacement of Prior Agreements. The District has recorded the following resolutions and entered into the following connector's agreements with Developer and its affiliates with respect to the Property (collectively the "Prior Agreements"):

(a) Resolution Establishing Tap Fees and User Fees recorded October 18, 2001 at Reception No. C0874738.

(b) Connector's recorded December 5, 2003 at Reception No. C1248735.

This Connector's Agreement supersedes and replaced, in their entirety, the Prior Agreements, solely and exclusively as it relates to the Property. The Prior Agreements shall be of no further force and effect solely and exclusively as it relates to the Property.

## II. CONDITIONS OF SERVICE

1. Service Limitations. Services shall be furnished under this Agreement to the Property to serve development that is determined by the District, as further described below, to equal but not exceed the equivalent of three hundred eighty-nine (389) single family equivalents, and subject to the provisions of this Agreement, non-potable irrigation water for single family equivalents within the Property and open spaces, park spaces and green spaces within the Property (the "Service Limit"). The District has secured from the Developer and reserved for that purpose water rights (the "Initial Water") in an amount sufficient to satisfy the Service Limit. Services to the Property in excess of that capable of being served with the Initial Water shall be contingent upon dedication to the District by Applicant of additional water rights in addition to the Initial Water, which additional water rights are, in the opinion of the District, adequate and acceptable for use by the District. Applicant shall be solely responsible for obtaining such additional water, provided however that the District shall have the right but not the obligation to make such water as the District, in its sole determination, has available for the Applicant's use on such terms and conditions as may be mutually acceptable. Developer, or its successors or assigns, shall submit to the District the irrigation and landscape plans for single family equivalents, together with irrigation plans, water budget and tap size justification for open spaces within the Property for review and approval, which approval shall not be unreasonably withheld, conditioned or delayed, and such plans and specifications shall adhere to the District's limitations on irrigated square footage for such single family equivalents not exceeding 3,000 square feet of blue grass sod or blue grass sod equivalent per single family equivalent.

2. Exclusivity. The parties hereto acknowledge and agree that the District is committing, subject to the terms hereof, to provide Services to the Property in perpetuity, which commitment includes the reservation of capacity in the District's existing system proportionate to that commitment. Accordingly, District shall be the sole source of Services to the Property, and Applicant may not utilize any alternate source of Services or allow any cross-connection of Services without the prior written authorization of the District.

3. Tap Conversion. In determining the number of Taps allowed for the Property, from time to time, the District shall calculate the Tap equivalent, per acre-foot of assumed actual production provided, utilizing the District's applicable conversion ratios, taking into account the use actually made of the Property. The number of Taps actually available will be subject to adjustment from time to time based on actual development and corresponding uses of the Property. The conversion ratios adopted from time to time shall be applied and implemented uniformly and consistently throughout the District Service Area and in accordance with the District's Resolutions, Rules and Regulations as the same may be amended from time to time.

4. Service Facilities.

A. Services to development on the Property shall be contingent upon Applicant providing, in accordance with the design standards and specifications adopted by the District, as the same may be amended from time to time, for all service facilities in such time frames and phases as are necessary to extend Services to and within the Property as development occurs. Service facilities shall mean raw water supply lines and facilities, treated water distribution lines, sewage collection lines and/or lift stations, irrigation lines, and also any

telecommunications systems necessary for tele-monitoring of the Services furnished to the Property from time to time (collectively, the "Facilities").

B. So long as the Tap Fees are timely paid, water wells or well equipment, water treatment or storage facilities, and any other necessary facilities that are not required to be provided by Applicant per subparagraph (A) above, shall be furnished by the District at its sole cost, and are not part of the Facilities that Applicant must provide. District shall have sole discretion in the timing of construction of these facilities provided that the District shall at all times be required to provide Services up to the Service Limit. In addition, notwithstanding any implications herein to the contrary, in the event the District shall determine to change locations for any Facilities after the same have been initially approved and installed by the Applicant, then the undertaking and cost of changing the locations, and correspondingly modifying the Facilities, will be borne and paid solely by the District.

5. Designation and Utilization of Well Sites.

A. Transfer of sites. Prior to the provision of Services to development on the Property as it occurs, District shall have the right to designate well sites within or without the District, or to change and relocate points of diversion of existing well sites. Such designation shall be made in such numbers and at such sites as will result in adequate production for a supply of water to the Property through the District's system. If such sites are on Applicant's property, Applicant agrees, upon the designation of such well site location or locations that are reasonably acceptable to Applicant, to grant the District a permanent, non-exclusive easement for utilization for such sites for a water supply well, together with a permanent, non-exclusive easement for water supply lines from the well(s) to the District treatment facilities and for access to such well sites as the District reasonably determines is necessary to provide access to same, and a temporary access easement for the purpose of constructing the well or wells in question. Such easements shall be granted by legally sufficient instruments at no cost to District and shall be in form and substance mutually agreeable to District and the Applicant.

C. Joint Sites. All well sites designated by the District shall be joint well sites for the purpose of serving both the Property and other District users. Such sites may be either on or off the Property, and shall be located in accordance with Section II. 5. A., above.

6. Commencement of Construction. With respect to the construction of the Facilities serving the Property, Applicant agrees as follows:

A. To obtain the District's approval, and as applicable the approval of the County, of the plans and specifications for the proposed Facilities, which approval shall be consistent with the prevailing standards and practices of the District, and may not be unreasonably withheld, denied or delayed. The Parties acknowledge and agree that the District and the County impose climate appropriate standards upon vertical development within the Property, which standards may impact the design, character, location and extent of the Facilities;

B. To construct all Facilities substantially in compliance with the approved plans and specifications of the District and, so long as the Applicant is in the process of developing the Property to hold harmless and indemnify the District for any and all losses or damages it may suffer or may be called upon to pay as a result of said construction to the extent

such losses or damages arise from the Applicant's failure to construct the Facilities in material conformity with the approved plans and specifications, or from any negligence or willful misconduct of Applicant in connection with construction of the Facilities; provided however, the foregoing indemnity shall automatically expire on the date of the District Acceptance of the Facilities for the last phase of Applicant's project on the Property, as hereafter defined;

C. To cause all Facilities, whether within or without the Property, to be placed either in District-approved easements which shall be conveyed to the District, or in public rights of way, in either event granting to District rights at least equal to rights it would enjoy in a dedicated street;

D. To permit District or its designee to observe and inspect any and all of the construction operations upon reasonable prior notice and permit the District to order cessation or appropriate modification of improper construction after providing Applicant notice of such improper construction and a reasonable opportunity to cure such improper construction;

E. To give District reasonable notification (in any event not less than 24 hours) of the time proposed to make connections to the District's then-existing lines or to place any meters;

F. To abide by all Rules and Regulations of the District, now or hereafter existing; and

G. To reimburse the District for all of its out-of-pocket engineering fees, inspection and approval fees, and other costs incurred by the District in accordance with its ordinary and uniformly applied practices, as a result of the District's oversight of construction of the Facilities, to be payable within 30 days after written notice and supporting documentation of such charges from time to time. Until paid, all such fees and costs shall be deemed fees of the District and as such shall constitute a lien against the development phase of the Property to which the particular Facilities relate, as provided for in C.R.S. Section 32-1-1001 (1)(j), as amended.

Applicant specifically acknowledges and agrees that the applicable development phase on the Property will not be entitled to receive Services pursuant to this Agreement unless and until the Facilities have been completed in conformity with the foregoing provisions. Pursuant to this limitation, the Applicant will not be required to furnish any performance or payment bonds, letters of credit, or other forms of surety or collateral for construction of the Facilities. The District will act reasonably with the Applicant to define the various phases of development.

7. Transfer of Facilities. Within thirty (30) days after the date of completion of the construction of Facilities for each phase of Applicant's project on the Property, and subject to the District's contemporaneous acceptance of those Facilities pursuant to Section II.8, below, Applicant shall:

A. Deliver to District a certificate from a registered professional engineer certifying that all Facilities have been built, and where appropriate are operating, substantially in accordance with the governing plans and specifications. If, within one (1) year from the date of such certification, any approved portion of such Facilities is defective or ceases to operate as intended, then the District may demand that Applicant replace the defective or improperly operating portion or portions of such Facilities and remedy said defective work and Applicant

shall promptly do so at its cost and expense. If within ten (10) days after receipt of written notice, Applicant is not diligently pursuing repairs and/or replacement or if circumstances require immediate repairs, District may undertake, without further notice to Applicant, the repairs and/or replacement at Applicant's expense.

B. Execute and deliver to District a good and sufficient bill of sale describing all of the components of the Facilities and all personal property of Applicant, of whatever character, relating to such Facilities, which bill of sale shall warrant that conveyance of the property described therein to District is made free from any claim or demand whatever (but subject to real property interests affecting the pertinent easement areas).

C. Execute and deliver to District good and sufficient instruments of transfer conveying all of Applicant's interest in any easements which may be required to give District the right to control the Facilities constructed including the right to ingress and egress necessary to operate and maintain them.

D. Provide District one reproducible Mylar of "as-built" drawings of the Facilities, certified by a registered, professional engineer.

E. Provide the District with a full and complete accounting reasonably acceptable to the District of all of the costs incurred by Applicant in completing the Facilities (the "Costs.")

Upon completion of the items set forth in this Section 7, the District shall accept dedication and ownership of the Facilities (the "District Acceptance"), and shall provide written notice to Applicant of such acceptance upon request of Applicant.

8. Completion of Facilities. In no event shall the District be required to provide Services to each completed phase on the Property or pay the Reimbursement, as defined below, until such time as it, in the exercise of its reasonable discretion, determines that the Facilities required to serve said phase have been completed substantially in accordance with the approved plans and specifications and transferred in accordance with this Agreement (provided that Applicant may condition such transfer upon its receipt of the District's contemporaneous written confirmation of such determination and corresponding acceptance of the Facilities subject to any applicable remedial periods set forth herein). The District will be responsible to maintain accepted Facilities in accordance with the other provisions of this Agreement; provided that if, in the exercise of its sole discretion, the District begins to provide Services to said phase prior to the time when the Facilities required to serve the phase have been so accepted by and transferred to the District, no use by the District of the Facilities constructed under this Agreement shall be considered a waiver of the District's right, in accordance with its prevailing standards and practices, to deem the Facilities, or any documentation, or information required by this Agreement unsatisfactory or incomplete, and to refuse service to the Property if the Facilities in fact have not been completed in conformity with the requirements hereunder, nor shall any use be considered an acceptance of the Facilities for maintenance; provided, however, that no refusal of service shall be enforced by District without providing Applicant thirty (30) days to cure whatever defect is in question or, if thirty days is an inadequate time period, such time period as the District may reasonably prescribe.

9. Cost Participation.

A. No Revenue Sharing. Except as specifically set forth in this Agreement, no revenue received by the District from the assessment of service charges and/or tap fees against the Property, as permitted hereunder and as permitted by the District's resolutions, rules and regulations as the same may be amended, shall afford Applicants any right of offset, rebate or refund for or against any obligation created by this Agreement.

B. Tap Fees. Notwithstanding Section 9.A., above, upon collection by the District of Tap Fees in accordance with the District standard procedures for such collection, for each Tap Fee collected the District shall pay to the Applicant the Applicant Tap Fee. Payment shall be made to the Applicant not more than monthly by the tenth business day of the month following the month for all Tap Fees collected in the prior month. Applicant agrees to purchase taps in minimum blocks of ten taps.

C. Sunset. The District agrees that, before December 31, 2026, tap fees payable with respect to development in the Property and Additional Property shall not exceed the Tap Fee. After December 31, 2026 the District may adjust the tap fee as it may, in its sole and unfettered discretion determine; provided that the Applicant Tap Fee shall continue to be the maximum amount owed to the Applicant.

10. Limitations on Use and Enjoyment. Any easements granted to the District pursuant to the provisions of this Agreement will be nonexclusive, and will be located so that the same will not cause any obstruction of or material interference with existing or prospective development within the Property or any portion thereof from time to time, or the use and enjoyment thereof, and the locations for well sites and related facilities shall be determined accordingly; provided that Applicant acknowledges that placement of fiber optic lines, utility lines, utility cabinets, transformers, vaults, and appurtenances by third parties within easements granted to the District could have a detrimental effect on the District's abilities to operate and maintain the Facilities, and to the extent practicable, and unless given the District's consent (not to be unreasonably withheld) Applicant will prohibit the placement of third party utility facilities and appurtenances in the easement areas granted to the District. The provisions of this Section II. 10. shall be controlling over any other provisions in this Agreement indicating to the contrary.

11. Other Governmental Approvals. The Applicant must make all reasonable, diligent, and good faith efforts to obtain any requisite permits or approvals for the Facilities from other governmental authorities having jurisdiction, including, without limitation, the Colorado Department of Public Health and Environment and the County.

III. OWNERSHIP AND OPERATION OF WATER AND SEWER FACILITIES

1. Facilities. The Parties acknowledge and agree that the ownership of all Facilities shall be in the District when accepted by and conveyed to the District in accordance with this Agreement. The District shall be responsible for the operation and maintenance of all Facilities subject to Section III. 2., below.

2. District Operation and Maintenance of the Water and Sewer Facilities. For purposes of this Agreement and to clarify the continuing obligation of the District to provide

Services to Applicant, the Property, as the same may be enlarged from time to time as permitted under Section III. 2. K., is hereinafter referred to as the "Contract Service Area."

A. The District agrees to furnish the Services within the Contract Service Area for all uses and purposes to which it is lawfully authorized, of a quality, and in quantities so as to provide adequate Services to all users, except as otherwise specifically provided under the terms of this Agreement. The Services so rendered by the District shall be pursuant to the same rules, regulations, policies and standards as if the Contract Service Area were inside the District. Nothing herein, however, shall prohibit the District from amending such rules, regulations, policies and standards in a fair, reasonable, and nondiscriminatory manner.

B. Applicant grants to the District the right to construct, own, use, connect, disconnect, modify, renew, extend, enlarge, replace, convey, abandon or otherwise dispose of any and all of the Facilities for providing Services within the Contract Service Area and to enable the District to perform its obligations as set forth in subsection III. 2. A., above. Applicant grants to the District the right, subject to this Agreement, to occupy any place, public or private, which Applicant has the right to occupy for the purpose of fulfilling the obligations of the District as set forth herein, and for the purpose of extending and continuing Services to its other customers. To implement the purposes of this Agreement, Applicant agrees to exercise such authority, to do such acts, and to grant such easements as may reasonably be requested by the District and are consistent with Applicant's rights hereunder.

C. Subject to receipt by the District of appropriate rates, charges, fees, tolls, or combinations thereof, as set forth in subsection III.2.D., the District agrees to maintain Facilities it owns or which come under its dominion hereunder by acceptance or otherwise, with reasonable and normal care to the extent that such maintenance is necessary to the furnishing of the Services provided for hereunder and to construct, operate, maintain and keep a complete inventory of such additional physical facilities as are necessary or desirable to accomplish the obligations it has undertaken for Applicant as set forth herein.

D. The District may establish, revise, impose and collect charges for the Services it provides users in the Contract Service Area hereunder, which charges shall be referred to as "service charges." In addition, the District may at any time impose tap fees as described above in this Agreement. Service charges and tap fees are separate charges and one does not include the other or any part thereof. All such fees and charges shall be uniform among members of each class of users within the Contract Service Area; provided that the District shall be authorized to discriminate in the assessment of fees and charges to account for the fact that property within the District may be assessed a tax levy for the purpose of defraying, in whole or in part, the costs of service provision, capital expenditures and the retirement of debt. Methods of collection of fees and charges shall be applied uniformly among similarly situated users within the Contract Service Area. Tap fees (including Tap Fees) will be a one-time charge for each discrete development of a parcel or building, payable prior to the commencement of construction and subsequent provision of water service to each parcel or building. Subject to the foregoing, the District shall have sole authority to impose and collect all fees and charges.

E. It is mutually agreed that the duration of this Agreement is such that the passage of time will require changes in the fees and service charges to be made for the Services to be rendered hereunder in the Contract Service Area, and that the most feasible way to insure

fairness will be to keep charges for the rendering of Services outside the District, but within the Contract Service Area, uniformly related to fees, service charges and taxes and other assessments of the District for the rendering of Services inside the District for similar service. It is therefore agreed that the District may modify the schedule of fees and service charges for Services provided hereunder, from time to time, in its discretion.

F. All the general rules and regulations and amendments thereto placed in force by the District from time to time concerning the operation of the District's service systems and conditions of service from those systems shall be as fully enforceable in the Contract Service Area as inside the District. Both parties to this Agreement recognize that the water supply for the Contract Service Area is dependent upon material resources from which the supply is variable in quantity and beyond the control of the District. Similarly, the provision and expansion of Services to the Contract Service Area is dependent upon the continued availability and operation of adequate treatment facilities which in turn are subject to the oversight and control of the County and the State of Colorado. No liability shall attach to the District for occurrences that are outside the reasonable control of the District, including without limitation restrictions on water supply during drought periods, system failures stemming from acts of God or third party interference, or limitations imposed by the County, and the State of Colorado or the federal government relating the District's facilities. Subject to receipt of appropriate rates, charges, fees, tolls, or combinations thereof, as set forth herein, the District agrees to provide adequate facilities to make available Services to the users within the Contract Service Area, considering known development schedules in existence as of the date hereof and currently projected development densities.

G. If conditions develop such that it becomes apparent to the District that the Contract Service Area cannot be supplied adequately due to the limitations set forth in subparagraph F above, the District reserves the right to discontinue the granting of additional Taps in the Contract Service Area; provided, however, that the District shall be obligated to exercise this right of suspension uniformly throughout the Contract Service Area for proposed uses which are similarly situated, and that the District will not discontinue granting of Taps for which Tap Fees have already been paid to the District. The District agrees to give six months' written notice to Applicant of such suspension, unless circumstances require a shorter period (and in any event Applicant shall receive no shorter or greater notice period than that provided in-District users) and the suspension will not apply during the notice period.

H. The parties agree that the District may, in order to comply with any applicable law, rule, directive or order, and to enable it to provide adequate Services to both the District and Applicant, as well as other customers of the District in times of shortage or other practical or legal limitations on the ability of the District to provide the Services contemplated hereby that are beyond the reasonable control of the District, limit and/or restrict the delivery of water and sewer services, and/or restrict the use of water delivered hereunder (for example, irrigation limitations during drought periods). The extent to which limitation of services may be necessary to enable the District to provide adequately for all users of the District's systems is a fact to be determined by the District as occasion may require; provided that in order to enable the District to provide an adequate supply of water to the people of the District without impairment of essential deliveries of water under this and similar agreements, the District will impose any restrictions or prohibitions uniformly inside and outside the District.

I. All water furnished by the District in providing Services hereunder is on a



leasehold basis for the use of users in the Contract Service Area for all the various purposes for which the District has been decreed the right to appropriate water. Such right on the part of the Applicant to use water does not include any right to make a succession of uses of such water and upon completion of the primary use all dominion over the water so leased reverts completely to the District. Except as herein specifically otherwise provided, all property rights to the water to be furnished by the District hereunder are reserved in the District. Nevertheless, it is mutually agreed that there is no obligation on Applicant or on the users within the Property with respect to creating any particular volume of return flow from water delivered hereunder.

J. All facilities installed or replaced by the District in the Contract Service Area shall be installed pursuant to its rules, regulations and standards. Said facilities shall be the property of the District.

K. No enlargement of the Contract Service Area by Applicant, or any other amendment of this Agreement, may be made except by mutual agreement entered into with the same formality as that employed in the execution of this Agreement; provided that upon closing by Applicant of its acquisition of the Additional Property, accompanied by the request by Applicant that the District extend the Services to the Additional Property pursuant to this Agreement, then in that event this Agreement shall be amended to include the same as being subject to all of its terms and conditions. In that event the Service Limit shall be expanded to accommodate the provision of Services to additional property, the Service Limit shall not exceed four hundred and twenty-nine (429) single family equivalents in the aggregate.

L. Applicant agrees that it will neither directly nor indirectly furnish, nor authorize the furnishing, of any Services within the Contract Service Area through the Facilities by anyone other than the District.

3. District Standards of Conduct. Applicant agrees that much of the District's obligation to serve Applicant and the Property set forth hereunder is a matter of discretion and response to ever changing demands upon the respective Facilities involved, and Applicant further agrees that where the District is explicitly or implicitly authorized to exercise its judgment under any of the provisions of this Agreement, its judgment shall not be questioned unless clearly arbitrary or capricious.

#### IV. MISCELLANEOUS

1. Indemnification by Applicant.

A. Applicant hereby agree to defend, indemnify and hold harmless the District from and against any and all liens, claims, demands, injuries, damages, costs, expenses (including without limitation reasonable attorneys' and legal assistants' fees) or liability incurred by or asserted against the District, through actions by persons or entities not party to this Agreement, as a result of or in any way arising out of the Applicant's installation and construction of the Facilities, except to the extent of the negligence or misconduct of or material breach of this Agreement by the District or its agents, contractors, independent contractors or employees. Said indemnification shall include, but not be limited to, court costs, damages, and reasonable attorneys' fees. The foregoing indemnification shall automatically terminate on the date of the District Acceptance.

B. After the District Acceptance, Applicant shall defend, indemnify and hold harmless the District from and against any and all liens, claims, Applicant hereby agree to defend, indemnify and hold harmless the District from and against any and all liens, claims, demands, injuries, damages, costs, expenses (including without limitation reasonable attorneys' and legal assistants' fees) or liability incurred by or asserted against the District, through actions by persons or entities not party to this Agreement, as a result of or in any way arising out any damages to the Facilities cause by Applicant or its contractors or employees.

2. Enforcement. Applicant and District acknowledge and agree that this Agreement may be enforced in law or in equity by decree of specific performance, damages, or other legal and equitable relief as may be available to either Party subject to the provisions of the laws of the State of Colorado; provided that consequential, incidental, special or punitive damages are not recoverable. The Parties specifically acknowledge that the timely performance of the obligations set forth in this Agreement is essential and that a failure to perform the obligations in breach of this Agreement may cause the other Party irreparable harm for which damages or other remedies available at law will not be adequate, and which may be adequately redressed only by specific performance or other appropriate equitable relief. The parties agree that in any action to enforce any provision of this Agreement the prevailing Party shall be entitled to recover from the other Party all of the prevailing Party's costs and expenses incurred in connection therewith, including reasonable attorneys' fees.

3. Successors and Assigns: Intergovernmental Agreement. All successors in interest to the Applicant in the ownership of the Property, or portions thereof, will acquire their interests subject to the conditions, requirements and limitations placed upon the provision of Services hereunder, and the authorizations and other rights (including lien rights) in favor of the District, and as such this Agreement shall constitute covenants running with the Property and shall be binding upon Applicant and their successors and transferees of the Property, to the extent of the portions of the Property that each of them owns; provided, however, that when a successor or transferee becomes entitled to receive Services hereunder, such Services shall not be conditioned upon or limited or terminated because of any failure, on the part of some other successor or transferee and with respect to another portion of the Property to satisfy any conditions, requirements or limitations placed thereon pursuant to this Agreement. Notwithstanding the foregoing provisions or any other provisions of this Agreement that may indicate to the contrary, and except to the extent specifically assumed by any such successor in writing, any such successor will not have any personal liability for the Applicant's remedial undertakings in relation to the construction of Facilities, or any other obligations of the Applicant hereunder required to be performed prior to the date of such transfer, except that (i) any such successor, in its capacity as a recipient of Services, will have the same obligations and liabilities to the District as are applicable to recipients of Services within the District, and (ii) any successor will be liable for remedial and any other obligations applicable to any Facilities that the successor may construct and dedicate to the District. The foregoing exculpation from personal liability in favor of successors will not preclude the District from enforcement by equitable remedies in the nature of specific performance or prohibitory injunctive relief that do not entail the recovery of damages or other sums or the incurrence of expenditures in order to comply. In order that notice of the District's authority hereunder may be given to all applicable property owners, Applicant agrees that this Agreement shall be recorded against the Property. Applicant agrees that it will not sell and convey any portion of the Property prior to the recording of this Agreement against the Property, and in addition the Applicant shall exercise reasonable and good faith efforts to secure the requisite

consents of the Property's mortgage lender, if any, to the terms of this Agreement and to it being made of record against the Property, and upon the occurrence of the latter event the Applicant and District shall record this Agreement against the Property.

5. Assignment. This Agreement may be assigned by Applicant only with the written consent of the District, which consent may be given or not in the sole discretion of the District. Any such attempted assignment without such consent shall be deemed void and of no force and effect.

6. Survival of Obligations. Notwithstanding the prohibition against unauthorized assignment set forth in Section IV. 5., above, the provisions of this Agreement shall be deemed to survive any transfer of the Property and shall be binding upon the successors to, and/or transferees, and assigns of the Applicant's interest in the Property.

7. Intentionally Omitted.

8. Severability: To the extent that this Agreement may be executed and performance of the obligations of the Parties may be accomplished within the intent of this Agreement, the terms of this Agreement are severable, and should any term or provision hereof be declared invalid or become inoperative for any reason, such invalidity or failure shall not affect the validity of any other term or provision hereof, provided that neither Party is materially deprived of the benefit of the intended bargain hereunder. The waiver of any breach of a term hereof shall not be construed as a waiver of any other term, or the same term upon subsequent breach.

9. Third Parties. It is expressly understood and agreed that enforcement of the terms and conditions of this Agreement, and all rights of action relating to such enforcement, shall be strictly reserved to the Parties hereto, and nothing contained in this Agreement shall give or allow any such claim or right of action by any other or third person on such Agreement. It is the express intention of the Parties hereto that any person other than Applicant and the District receiving Services or benefits under this Agreement shall be deemed to be an incidental beneficiary only. However, the District specifically acknowledges and agrees that its obligations and undertakings hereunder will inure to the benefit of and may be enforced by Applicant's permitted successors and assignees.

10. Authority and Term. Each Party hereto represents and warrants that all actions have been taken that are necessary or that are required by its procedures, bylaws, or applicable law, to legally authorize the undersigned signatory to execute this Agreement on behalf of such Party and to bind such Party to its provisions; and that such Party otherwise has all requisite legal authority to bind itself to the provisions hereof, for the full term of this Agreement, and without any further action on the part of such Party or any third party or authority. The term of this Agreement shall be in perpetuity.

11. Termination for Breach and Waiver.

A. It is essential to the interests of each Party that this Agreement be maintained in effect, in accordance with its intent, and therefore neither Party shall have the contract remedy, generally afforded by law, to terminate this Agreement for a breach of the other Party's obligations hereunder; provided, however, that the foregoing shall not impair the non-

defaulting Party's rights to pursue appropriate equitable relief as otherwise provided herein, or any express right of termination set forth under the other provisions of the Agreement.

B. No waiver by any of the Parties of any covenant, term, condition, or agreement contained herein shall be deemed or construed as a waiver of any other covenant, term, condition, or agreement, nor shall a waiver of any breach hereof be deemed to constitute a waiver of any subsequent breach, whether of the same or of a different provision of this Agreement.

12. Notices. Any and all notices required to be given by this Agreement are deemed to have been received and to be effective: (1) upon hand delivery, or (2) upon 3 days after the same shall have been mailed by certified mail, return receipt requested; to the address of the Parties as set forth below or to such other Party or addresses as may hereafter be designated in writing.

To Applicant:

Forestar (USA) Real Estate Group Inc.  
Attn: Matthew Napier  
9555 S. Kingston Ct. Suite 200  
Englewood, Colorado 80112  
Phone: 303-754-3219  
Email: matthewnapier@forestar.com

With copy to: Moye White LLP  
1400 16th Street, 6th Floor  
Denver, CO 80202  
Attn: Amy H. Ruhl, Esq.  
Email: amy.ruhl@moyewhite.co

To District:

Eastern Adams County Metropolitan District  
100 St Paul Street, Suite 100  
Denver, Colorado 80206  
Attention: Mike Serra III

With a copy to:

Spencer Fane LLP  
1700 Lincoln Street, Suite 2000  
Denver, CO 80203  
Attn: Matthew Dalton  
Email: mdalton@spencerfane.com

13. Incorporation of Exhibits. All Exhibits attached hereto and referenced herein are incorporated into this Agreement by this reference.

14. Governing Law, Venue. This Contract shall be construed in accordance with the laws of the State of Colorado. Venue shall be in the District Court in and for the County of Adams, State of Colorado.

15. Estoppel Certificates. With fifteen (15) days after request therefor from time to time by notice, the Party which is the recipient of the request shall execute and deliver an estoppel certificate confirming that this Agreement remains in full force and effect in accordance with its stated provisions (subject to any appropriate qualifications that the request may disclose). Additionally the request may ask that the response set forth any outstanding sums that the requested Party claims are then due and owing to the requested Party under this Agreement, and any claims by the requested Party of any outstanding breaches or defaults of this Agreement by any other Party bound hereby, and the status of such other matters related to the terms of this Agreement as may be reasonably set forth by the requesting Party in its notice of request. Any estoppel certificate so tendered may be relied upon by the requesting Party and its designees.

16. Governmental Immunity. The District, its directors, officials, officers, agents and employees are relying upon and do not waive or abrogate, or intend to waive or abrogate, by any provision of this Agreement the monetary limitations or any other rights immunities or protections afforded by the Colorado Governmental Immunity Act. C.R.S. § 24-10-101, et seq., as the same may be amended.

17. Appropriation. All financial obligations of the District under and pursuant to this Agreement are subject to prior appropriations of monies expressly made by the District for the purposes of this Agreement.

18. No Personal Liability. No elected official, director, officer, agent or employee of the District or Applicant shall be charged personally or held contractually liable by or to the other party under any term or provision of this Agreement or because of any breach thereof or because of its or their execution, approval or attempted execution of this Agreement.

[Signature Pages Follow]



**DISTRICT:**

**EASTERN ADAMS COUNTY METROPOLITAN DISTRICT**  
A quasi-municipal corporation and political subdivision of the  
State of Colorado

By: [Signature]  
Name: Mike Serra III  
Title: Vice President

Date: February 16, 2021

STATE OF Colorado )

)ss.

COUNTY OF Denver )

On this day, before me, a Notary Public, duly commissioned, qualified and acting, with and for said County and State, appeared in person the within named Mike Serra III, to me well known, who stated he/she was the Vice President of EASTERN ADAMS COUNTY METROPOLITAN DISTRICT, a quasi-municipal corporation and political subdivision of the State of Colorado, and was duly authorized in such capacity to execute the foregoing instrument for and in the name and on behalf of the company, and further stated and acknowledged he/she had so signed, executed and delivered the foregoing instrument for the consideration, uses and purposes therein mentioned and set forth.

IN TESTIMONY WHEREOF, I have hereunto set my hand and official seal this 16<sup>th</sup> day of February, 2021.

[Signature]  
Notary Public

My commission expires:

07/14/2023  
(SEAL)

REBECCA TALADAY  
NOTARY PUBLIC  
STATE OF COLORADO  
NOTARY ID 20034020980  
MY COMMISSION EXPIRES 07/14/2023

EXHIBIT A

PROPERTY

LOTS 1 THROUGH 18, INCLUSIVE, BLOCK 1,  
LOTS 1 THROUGH 12, INCLUSIVE, BLOCK 2,  
LOTS 1 THROUGH 22, INCLUSIVE, BLOCK 3,  
LOTS 1 THROUGH 23, INCLUSIVE, BLOCK 4,  
LOTS 1 THROUGH 3, INCLUSIVE, BLOCK 5,  
LOTS 1 THROUGH 11, INCLUSIVE, BLOCK 6,  
LOTS 1 THROUGH 13, INCLUSIVE, BLOCK 7,  
TRACTS B, C, D, E, F, H, I, J, K, M, N AND P,  
WOLF CREEK RUN WEST FILING NO. 1, RECORDED OCTOBER 8, 2020 UNDER RECEPTION  
NO. 2020000102832, IN THE OFFICE OF THE CLERK AND RECORDER OF ADAMS COUNTY.  
COLORADO.



EXHIBIT B

ADDITIONAL PROPERTY

A PARCEL OF LAND BEING A PORTION OF THE SOUTH ONE HALF OF SECTION 29,  
TOWNSHIP 3 SOUTH, RANGE 62 WEST OF THE 6TH PRINCIPAL MERIDIAN, COUNTY OF  
ADAMS, STATE OF COLORADO, MORE PARTICULARLY DESCRIBED AS FOLLOWS:

COMMENCING AT THE CENTER ONE-QUARTER CORNER OF SAID SECTION 29, SAID  
POINT BEING THE TRUE POINT OF BEGINNING; THENCE NORTH 89°41'14" EAST ALONG  
THE NORTH LINE OF THE SOUTHEAST ONE-QUARTER OF SAID SECTION 29 A DISTANCE  
OF 1743.36 FEET;

THENCE SOUTH 00°33'44" WEST A DISTANCE OF 200.00 FEET;

THENCE NORTH 89°41'47" EAST A DISTANCE OF 800.00 FEET TO A POINT ON THE WEST  
RIGHT-OF-WAY LINE OF PIGGOTT ROAD (PER ROAD PETITION #538);

THENCE SOUTH 00°33'44" WEST, 30.00 FEET WEST OF AND PARALLEL WITH THE EAST  
LINE OF THE SOUTHEAST ONE-QUARTER OF SAID SECTION 29 AND ALONG THE WEST  
RIGHT-OF-WAY LINE OF SAID PIGGOTT ROAD A 2415.81 FEET TO A POINT ON THE  
NORTH RIGHT-OF-WAY LINE OF 26TH AVENUE (PER ROAD PETITION #538);

THENCE NORTH 89°59'43" WEST, 30.00 FEET NORTH OF AND PARALLEL WITH THE  
SOUTH LINE OF SAID SECTION 29 AND ALONG THE NORTH RIGHT-OF-WAY LINE OF  
SAID 26TH AVENUE A DISTANCE OF 4134.94 FEET;

THENCE NORTH 00° 24'32" EAST A DISTANCE OF 1281.73 FEET;

THENCE SOUTH 89°50'58" EAST A DISTANCE OF 287.67 FEET;  
THENCE NORTH 00°24'32" EAST A DISTANCE OF 809.68 FEET;  
THENCE SOUTH 69°39'32" EAST A DISTANCE OF 771.26 FEET;

THENCE NORTH 52°49'54" EAST A DISTANCE OF 736.37 FEET TO A POINT ON THE WEST  
LINE OF THE SOUTHEAST ONE-QUARTER OF SAID SECTION 29;

THENCE NORTH 00°48'52" EAST ALONG THE WEST LINE OF THE SOUTHEAST ONE-  
QUARTER OF SAID SECTION 29 A 330.00 FEET TO THE TRUE POINT OF BEGINNING.

LESS THAT PORTION OF QUIT CLAIM DEED RECORDED DECEMBER 11, 2002 AT  
RECEPTION NO. C1065639 OF SAID ADAMS COUNTY RECORDS LYING WITHIN THE  
ABOVE DESCRIBED PARCEL;

LESS ALL OF BLOCKS 1, 2, 3, 4, 5, 6 AND 7 AND TRACTS B, C, D, E, F, G, H, I, J, K, L, M, N  
AND P, WOLF CREEK RUN WEST FILING NO. 1, RECORDED OCTOBER 8, 2020 AT  
RECEPTION NO. 2020000102832 OF SAID ADAMS COUNTY RECORDS PER PREVIOUSLY  
RECORDED QUIT CLAIM DEED;

LESS ALL ROADS AS SHOWN ON THE PLAT OF SAID WOLF CREEK RUN WEST FILING  
NO. 1 DEDICATED TO ADAMS COUNTY, LYING WITHIN THE ABOVE DESCRIBED  
PARCEL;

LESS TRACT O OF SAID WOLF CREEK RUN WEST FILING NO. 1 LYING WITHIN THE  
ABOVE DESCRIBED PARCEL;

LESS LOT 1, BLOCK 8, WOLF CREEK RUN WEST FILING NO. 1.



---

10825 E Geddes Ave Suite 410 ▪ Centennial, CO 80112 ▪ Phone (720) 981-2123 ▪ [www.coloradonaturalgas.com](http://www.coloradonaturalgas.com)

September 12, 2023

Manhard Consulting  
1 N Broadway Street  
Suite B200  
Denver, CO 80203  
Attn: Chris Sandor

**Re: Colorado Natural Gas, Inc. – Gas service to the proposed Wolf Creek Run West – Filing 2 Subdivision in Strasburg, CO.**

To Whom It May Concern:

Colorado Natural Gas (CNG) has recently been contacted about providing natural gas service to the Wolf Creek Run West – Filing 2 Subdivision (located on the NW corner of the Piggot Rd and E 26<sup>th</sup> Avenue intersection in Adams County, Strasburg, CO).

Upon successful execution of contract terms agreed to by both parties, as well as receipt of any Contribution In Aid of Construction (CIAC) payments necessary, CNG can and will serve the Wolf Creek Run West – Filing 2 Subdivision by installing the infrastructure necessary (piping, regulator station, etc) to provide natural gas service.

Sincerely,

Colorado Natural Gas, Inc.

A handwritten signature in black ink, appearing to read "Ben Watkin".

Ben Watkin  
Manager of Engineering

September 13, 2023

Carlton Babbs  
Eastpeak Land  
1771 S Humboldt Street  
Denver, CO 80210

Re: Wolf Creek Run West Filing No. 2

Dear Mr. Babbs:

We are an electric utility operating under the rules and regulations approved by our Board of Directors. The above-referenced parcel of land in Section 29, Township 3 South, and Range 62 West of the 6<sup>th</sup> P.M., County of Adams, State of Colorado, and containing 108 residential lots is located within our service area.

We are willing to extend our facilities to the proposed project in accordance with our extension policies. When you submit an application for service, the designer assigned will be able to answer any questions concerning the location of electric facilities in relation to the project. Any attempt to identify facilities now may provide inaccurate information due to the phasing of your project and other developments in the vicinity, which may alter the location or type of facilities prior to your request for service.

If you have any further questions, please feel free to contact me.

Sincerely,



Brooks Kaufman  
Lands and Rights-of-Way Manager



# TREASURER & PUBLIC TRUSTEE

## ADAMS COUNTY, COLORADO

### Certificate Of Taxes Due

Account Number R0208855  
 Parcel 0181329200008  
 Assessed To  
 PAULS DEVELOPMENT EAST LLC  
 100 SAINT PAUL ST, STE 300  
 DENVER, CO 80206-5136

Certificate Number 2024-243351  
 Order Number  
 Vendor ID 35  
 ICE MORTGAGE TECHNOLOGY  
 601 RIVERSIDE AVE.  
 JACKSONVILLE, FL 32204

**Legal Description**

**Situs Address**

SECT,TWN,RNG:29-3-62 DESC: PARC IN SEC 29 DESC AS FOLS BEG AT A PT 30 FT E OF AND 30 FT S OF THE NW COR SD SEC 29 SD PT BEING THE TRUE POB TH E 2629/32 FT TO A PT ON N/S C/L OF SD SEC 29 TH S 2639/50 FT TH E 2543/36 FT TO A PT ON W ROW LN OF PIGGOTT RD TH S 2615/81 FT TH W 2554/66 FT TH W 2490/07 FT TO A PT ON E ROW LN OF 60 FT WIDE ROADWAY TH THE FOL 3 COURSES ALG THE E ROW LN TH N 03D 19M E 727/26 FT TO A P C TH ALG THE ARC OF CURVE TO LEFT HAV A C/A OF 09D 35M RAD OF 1504 FT AND AN ARC LN GO 251/86 FT WHOSE CHD BRS N 251/56 FT TH N 06D 15M W 303/50 FT TH E 1203/91 FT TH N 1312/50 FT TH W 1281/12 FT TH N 2655/19 FT TO THE TRUE POB TOG WITH A PARC BEING A PORT OF THE SW4 OF SEC 39 DESC AS FOLS BEG AT A PT 30 FT E OF AND 30 FT N OF THE SW COR SD SEC 29 SD PT BEING THE TRUE POB TH 1347/38 FT TO A PT OF INTERSEC WITH THE ROW LN OF 60 FT WIDE ROADWAY TH THE FOL 3 COURSES ALG W LN TH S 06D 15M E 378/68 FT TO A P C TH ALG ARC OF CURVE TO RT HAV A C/A OF 09D 35M RAD OF 1444 FT AND AN ARC LN OF 241/81 FT TH S 03D 19M W 730/75 FT TH W 5/05 FT TO THE TRUE POB EXC PARCS 341/824A EXC PT PLATTED AS WOLF CREEK RUN WEST FLG 1 REC 2020000102832 270/3589A

| Year                                    | Tax      | Interest | Fees   | Payments   | Balance       |
|---|----------|----------|--------|------------|---------------|
| <b>Tax Charge</b>                       |          |          |        |            |               |
| 2023                                    | \$945.92 | \$0.00   | \$0.00 | (\$945.92) | \$0.00        |
| Total Tax Charge                        |          |          |        |            | \$0.00        |
| <b>Grand Total Due as of 04/03/2024</b> |          |          |        |            | <b>\$0.00</b> |

Tax Billed at 2023 Rates for Tax Area 401 - 401

| Authority                   | Mill Levy  | Amount   | Values         | Actual   | Assessed |
|-----------------------------|------------|----------|----------------|----------|----------|
| RANGEVIEW LIBRARY DISTRICT  | 3.6530000  | \$38.79  | AG DRY FARMING | \$40,221 | \$10,620 |
| FIRE DISTRICT 8 - STRASBURG | 12.6140000 | \$133.96 | LAND           | \$40,221 | \$10,620 |
| ADAMS COUNTY                | 26.8350000 | \$284.99 | Total          | \$40,221 | \$10,620 |
| NORTH KIOWA BIJOU GROUND WA | 0.0190000  | \$0.20   |                |          |          |
| SD 31                       | 40.9390000 | \$434.77 |                |          |          |
| STRASBURG PARK & RECREATION | 5.0100000  | \$53.21  |                |          |          |
| Taxes Billed 2023           | 89.0700000 | \$945.92 |                |          |          |

ALL TAX SALE AMOUNTS ARE SUBJECT TO CHANGE DUE TO ENDORSEMENT OF CURRENT TAXES BY THE LIENHOLDER OR TO ADVERTISING AND DISTRRAINT WARRANT FEES. CHANGES MAY OCCUR; PLEASE CONTACT THE TREASURER'S OFFICE PRIOR TO MAKING A PAYMENT AFTER AUGUST 1. TAX LIEN SALE REDEMPTION AMOUNTS MUST BE PAID BY CASH OR CASHIER'S CHECK.

SPECIAL TAXING DISTRICTS AND THE BOUNDARIES OF SUCH DISTRICTS MAY BE ON FILE WITH THE BOARD OF COUNTY COMMISSIONERS, THE COUNTY CLERK, OR, THE COUNTY ASSESSOR.

This certificate does not include land or improvements assessed under a separate account number, personal property taxes, transfer tax, or, miscellaneous tax collected on behalf of other entities, special or local improvement district assessments, or mobile homes, unless specifically mentioned.

I, the undersigned, do hereby certify that the entire amount of taxes due upon the above described parcels of real property and all outstanding lien sales for unpaid taxes as shown by the records in my office from which the same may still be redeemed with the amount required for redemption on this date are as noted herein. In witness whereof, I have hereunto set my hand and seal.

TREASURER & PUBLIC TRUSTEE, ADAMS COUNTY, Alexander

L Villagran



4430 S. Adams County Parkway  
 Brighton, CO 80601



### Colorado Geological Survey Payment Portal

Receipt Number: 781958

Colorado Geological Survey  
 Current Date: 09/13/2023

| Description  | Amount Tax        |
|--|-------------------|
| Pre-Pay the Colorado Geological Survey Land Use Review Fee<br>Must select project size to calculate a price: Large Subdivision -<br>Project Name: Wolf Creek Run West - Filing 2<br>County of Project: Adams County<br>Applicant's Name: Carlton Babbs<br>Applicant's Address (line 1): 1771 S Humboldt Street<br>Applicant's City: Denver<br>Applicant's State: CO<br>Applicant's Zip Code: 80210<br>Applicant's Phone: 303-881-8962<br>Applicant's Email: cbabbs@eastpeakland.com<br>Section: 29<br>Township: 3S<br>Range: 62W | \$1,550.00        |
| Pre-Pay the Colorado Geological Survey Land Use Review Fee   |                   |
| <b>Total</b>   | <b>\$1,550.00</b> |

| Payments Received   | Amount            |
|---|-------------------|
| CC<br>American Express XXXXXXXXXXXX6002<br>Authorization # 257320 | \$1,550.00        |
| <b>Total</b>  | <b>\$1,550.00</b> |

Thank you for the payment.